



IRIDIUM

PLATINUM

HIGH IGNITABILITY

CERAMICS

TECH

PRECIOUS METAL



**MARINE
SPARK PLUGS**

2014/2015

AUSTRALIA & NEW ZEALAND CATALOGUE



Proudly Distributed by: *Sam Allen Wholesale*
385 Thynne Road,
Morningside, Queensland 4170
P: +61 7 3902 7222
F: +61 7 3899 1079
E: sales@samallen.com.au
W: www.samallen.com.au



High Ignitability. It's that simple.



Bright Sparks understand that high ignitability is the core reason for using precious metals in premium quality spark plugs. High ignitability means that a spark plug can ignite very lean air/fuel mixtures and this in turn ensures the complete combustion cycle occurs. The result is:

- Optimum Fuel Economy = Cost Savings
- Increased Power = Superior Performance
- Lower Emissions = Reduced Environmental Impact

So the next time you install a set of NGK Precious metal spark plugs, use them for the right reason.

High ignitability. It's that Simple.

To find out more about precious metal spark plugs
call +61 7 3902 7222 or visit www.samallen.com.au



NGK/NTK E-Learning

Accomplish NGK and NTK product modules.
Learn the basics of the products and beyond.
Receive a certificate upon completion of each module.

- PART NUMBER IDENTIFICATION** 3
- TECHNICAL INFORMATION** 9
- SPARK PLUG RANGE** 17
- SPARK PLUG RESISTOR CAP RANGE** 33
- MARINE – OUTBOARD RANGE** 39
- MARINE – INBOARD RANGE** 61
- MARINE – PERSONAL WATERCRAFT** 71
- CROSS REFERENCE CHART** 77
- DISCONTINUED & REPLACEMENT LIST** 121
- GLOSSARY** 125

SPARK PLUG GAP CONVERSION TABLE

MM	INCHES
0.4	0.016
0.5	0.020
0.6	0.024
0.7	0.028
0.8	0.032
0.9	0.036
1.0	0.040
1.1	0.044
1.2	0.048
1.3	0.052
1.4	0.056
1.5	0.060
1.6	0.064
2.0	0.080

NOTE: This catalogue lists only applications officially imported or manufactured in Australia. It does not apply to aircraft, racing or modified engines. Whilst every care is taken in compiling the recommendations found in this catalogue, they do not form part of any contract or other relationship and we do not accept responsibility in respect of any claim for negligence or otherwise whatsoever and howsoever caused arising from the publication of this catalogue.



NOTES

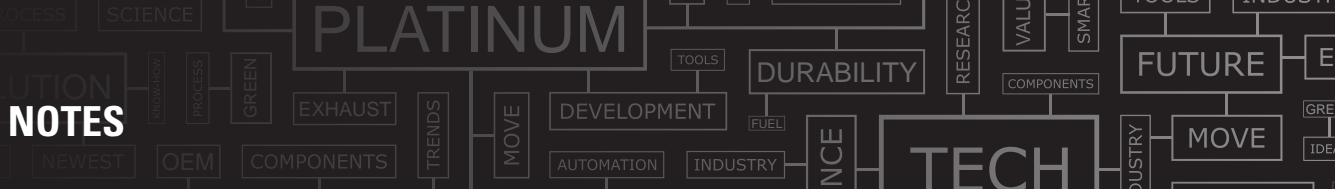

IRIDIUM

PLATINUM

PART NUMBER IDENTIFICATION

FUTURE

PRECIOUS METAL

AUTOMATION

VALU

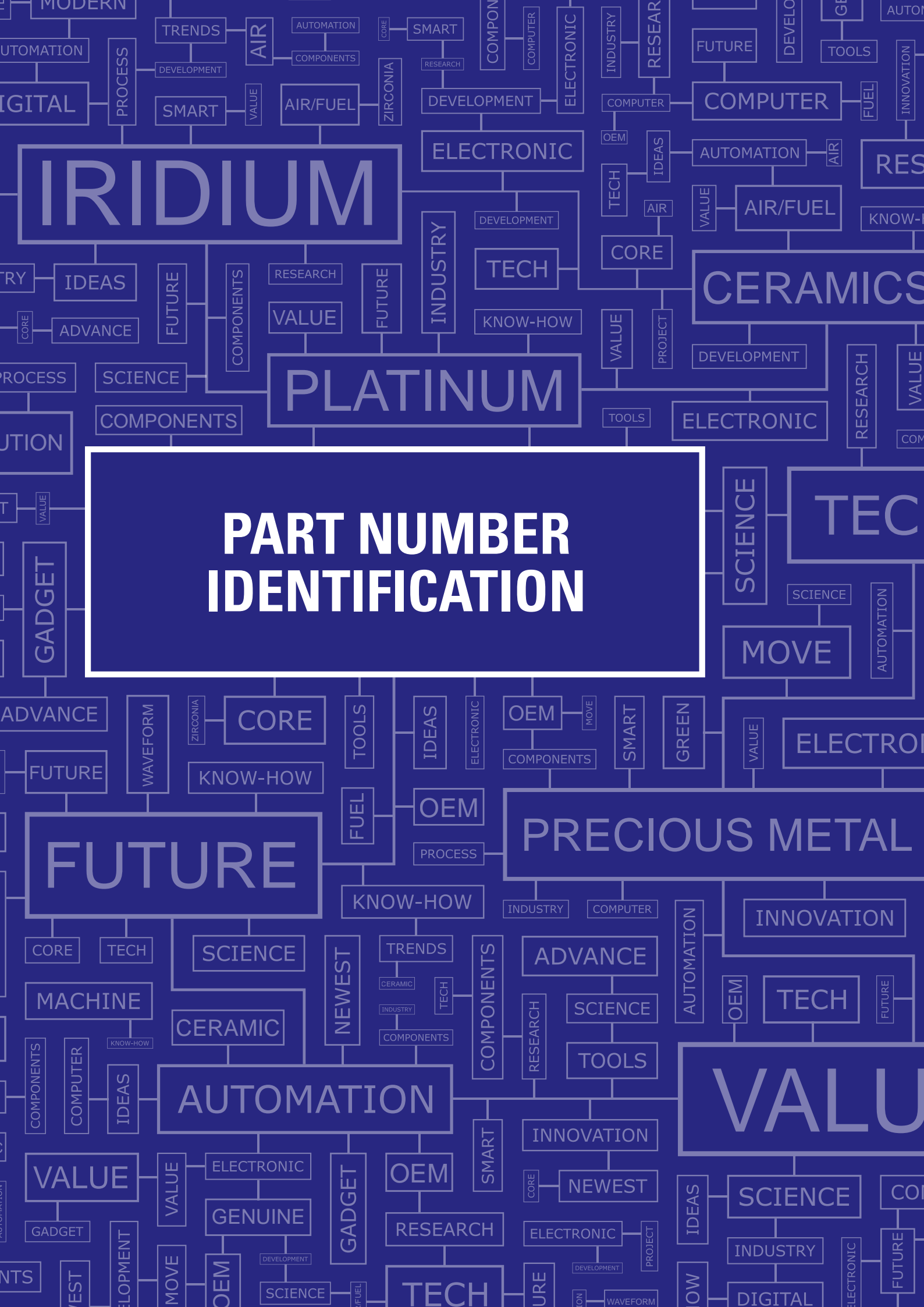



PART NUMBER IDENTIFICATION SPARK PLUG

B			P		R		5		E		S		-11	
Thread Size		Hex	Construction		Resistor		Heat Rating		Thread Reach		Firing end Construction		Spark Gap	
AB	ø18.0	Hex 20.8	P	Projected insulator type	R	Resistor	2	Hot type	E	19.0mm	B	Integral terminal (CR8EB)	None	motorcycle: 0.7-0.8mm car: 0.8-0.9mm
B	ø14.0	Hex 20.8	M	Compact type (Bantam)	Z	Inductive resistor type	4		EF	17.5mm	CM	Low angle ground electrode. Compact type (insulator length:18.5mm)	-8	0.8mm
BC	ø14.0	Hex 16.0	U	Surface or Semi-surface discharge type or Supplementary type			5		EH	19.0mm half-thread :12.7mm	CS	Low angle ground electrode	-9	0.9mm
BK	ø14.0	Hex 16.0					6		H	12.7mm	G,GV	Racing spark plug	-10	1.0mm
C	ø10.0	Hex 16.0					7		L	11.2mm	I	One-side Iridium spark plug	-11	1.1mm
D	ø12.0	Hex 18.0					8		None	• Conical-seat type A(P)-F:10.9mm B(P)-F:11.2mm B(P)M-F:7.8mm	IX	Iridium IX spark plug	-13	1.3mm
DC	ø12.0	Hex 16.0					9				J	2-projected-electrode for DAIHATSU	-15	1.5mm
E	ø8.0	Hex 13.0					10		Cold type	• Bantam type B(P)M:- 9.5mm B-LM: 9.5mm CM:- 9.5mm CM-6: 8.6mm C-50: 8.5mm	K	2-ground-electrode		
<p>*Except: B(P)M-A,Y: ø14.0, Hex 19.0 B(P)-(E)F: ø14.0, Hex 16.0 CM-6: ø10.0, Hex 14.0</p> <p>BC Japanese Industrial Standards (JIS). The length from the gasket circuit to the terminal contact on parts is 53.0mm.</p> <p>BK The length from the gasket circuit to the terminal contact on parts is 50.5mm.</p>							-L		Medium heat rating					
							-LM		Compact type (insulator length:14.5mm)					
			N	Special ground electrode	-S	Special gasket								
			P	Platinum spark plug single ground electrode :Double Platinum multi-ground electrodes type:Single Platinum	-E	Special resistance								
			Q	4-ground-electrode	IX-P	Iridium MAX spark plug								
			S	Standard type										
<p>Note: This table shows how to read general part numbers</p>			T	3-ground-electrode										
			U	Semi-surface discharge type										
			VX	VX spark plug										
			Y	V-grooved center electrode										
			Z	Special design										

P		F				R		5		A		-11		
		Thread Dimensions / Hex. Size				Resistor		Heat Rating		Firing end Construction		Spark Gap		
DI	High ignitability plug Double fine electrodes	F	ø14.0	19.0mm	Gasket	Hex 16.0	R	Resistor	2	Hot type	A,B,C: Special design The latter letter shows not material name but suffix code. Ex. IZFR6P8: Iridium plug I: Iridium Plug P: Suffix Code	None	motorcycle: 0.7-0.8mm car: 0.8-0.9mm	
I	Iridium spark plug	G	ø14.0	19.0mm	Gasket	Hex 20.8			4			-7	0.7mm	
L	Long thread reach plug	J	ø12.0	19.0mm	Gasket	Hex 18.0			5			-9	0.9mm	
P	Platinum spark plug	K	ø12.0	19.0mm	Gasket	Hex 16.0			6			-10	1.0mm	
S	High ignitability plug: Square tip type	KA	ø12.0	19.0mm	Gasket	Hex 14.0			7			-11	1.1mm	
Z	Extended Gap	KB	ø12.0	19.0mm	Gasket	Bi-Hex 14.0			8			-13	1.3mm	
Above alphabets are occasionally used in combination. Ex. ILFR..., PLZFR... "L", long thread reach, is prior to other letters which stand for thread reach. Ex. • Gasket type FR5AP-11: reach 19.0mm ↓ LFR5AP-11: reach 26.5mm • Conical-seat type PTR5C-13: reach 17.5mm ↓ PLTR6A-10G: reach 25.0mm	L	ø10.0	12.7mm	Gasket	Hex 16.0	*Except: TR5A-10, TR5A-13, TR5B-13, TR6B-10, TR6B-13, PTR5A-10, PTR5A-13: Thread reach 25.0mm *It requires socket wrench for Bi-HEX type.			9			-15	1.5mm	
	M	ø10.0	19.0mm	Gasket	Hex 16.0				10			Cold type	-A	Non gasket
	MA	ø10.0	19.0mm	Gasket	Hex 14.0							-D	Metal shell plating spec change	
	NA	ø12.0	17.5mm	Conical-seat	Hex 14.0							-E	Special resistance	
	T	ø14.0	17.5mm	Conical-seat	Hex 16.0						-G	Copper core ground electrode		
	U	ø14.0	11.2mm	Conical-seat	Hex 16.0			-H	Special thread type					
	W	ø18.0	10.9mm	Conical-seat	Hex 20.8			-J	2-ground-electrode					
	X	ø14.0	9.5mm	Gasket	Hex 20.8			-K	Vibration-resistant ground electrode					
Y	ø14.0	11.2mm	Conical-seat	Hex 16.0		-N	Special ground electrode							
								-Q	4-ground-electrode					
								-S	Special gasket					
								-T	3-ground-electrode					
								IX-P	Iridium MAX spark plug					

SUFFIX CODE

	X	Spark position (Y)	Shell projection dimension (Z)	Code
PFR5A-11	53.0 (JIS)	3.5	0	JIS specification
PFR5A-11A	53.0 (JIS)	3.5	0	No plug gasket type of PFR5A-11
PRF5A-11B	53.0 (JIS)	6.5	3.5	Metal Shell projection
PRF5B-11, (-9)	50.5 (ISO)	3.5	0	ISO spec of PRF5A-11
PFR5B-11B	50.5 (ISO)	6.5	3.5	Metal Shell projection
PRF5B-11C	50.5 (ISO)	3.5	1.5	Ground electrode spec change, Metal Shell projection
PRF5B-D	50.5 (ISO)	3.5	0	Metal Shell plating spec change
PRF5C-11	50.5 (ISO)	3.5	0	Ground electrode spec change of PFR5B-11
PRF5E-11A	53.0 (JIS)	3.5	0	No plug gasket type, Ground electronic spec change of PFR5A-11
PFR6G, (-11)	50.5 (ISO)	3.5	0	Ground electrode spec change of PFR6C-11
PF5JJ - 11	50.5 (ISO)	3.5	0	Ground electrode specification change of PRF5B-11
PFR5K-11	53.0 (JIS)	3.5	0	JIS spec of PRR5G-11
PFR5L-11	50.5 (ISO)	3.5	0	Ground electrode spec change of PFR6G-11
PFR6M	50.5 (ISO)	3.5	0	Ground electrode spec change of PRF6J-11
PFR6N, (-11)	50.5 (ISO)	3.5	0	Electrodes spec change
PFR5P, (-11)	50.5 (ISO)	3.5	0	Specification with thermo-edge
PZFR6B	50.5 (ISO)	5.0	0	Manufacturer use only, Projected core nose
PZFR5C	50.5 (ISO)	7.0	3.0	Manufacturer use only, Metal Shell projection
PZFR5E, (-11)	50.5 (ISO)	5.0	0	Projected core nose
PGR6A, (-11)	56.0	3.5	0	Platinum type of BPR6ES
PGR6A-D	56.0	3.5	0	Metal Shell plating spec change
PGR6C-11	56.0	3.5	0	Electrodes specification change
PGR6D	56.0	3.5	0	Ground electrode specification change
PLFR6A-9, (-11)	50.5 (ISO)	3.5	0	Thread length 26.5mm
PLFR6B-10	50.5 (ISO)	3.5	0	Thread length 26.5mm, ground electrode specification change
LFR5AQP	50.5 (ISO)	3.5	0	Thread length 26.5mm, 4 ground electrodes, platinum centre electrode
LZFR5AQP	50.5 (ISO)	6.5	3.0	Thread length 26.5mm, 4 ground electrodes, Metal Shell projection, platinum centre electrode
ZFR5A-11	53.0 (JIS)	5.0	0	JIS specification V-groove center electrode, core nose projection
ZFR5E-11	50.5 (ISO)	6.5	3.5	V-groove center electrode, shell projection
ZFR6F-11	50.5 (ISO)	5.0	0	V-groove center electrode, core nose projection
ZFR6F-11G	50.5 (ISO)	5.0	0	V-groove center electrode, core nose projection, copper core in ground electrode
ZGR5A	56.0	5.0	0	V-groove center electrode, core nose projection
ZGR5C	56.0	8.5	3.0	V-groove center electrode, core nose projection, Metal Shell projection

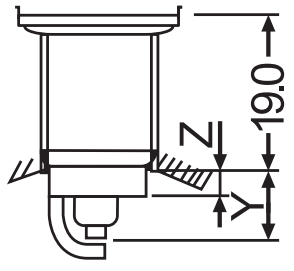
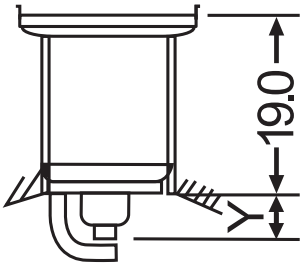
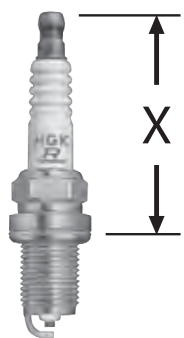
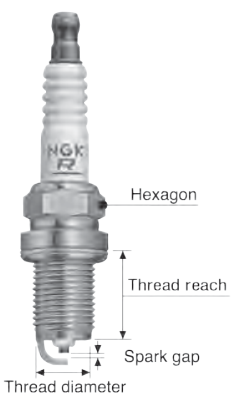



PART NUMBER IDENTIFICATION SPARK PLUG

RE		7		C	-L			
		Heat Rating						
RE	Plug for rotary engines	5	Hot type ↑ ↓ Cold type	A,B,C...Suffix code	-L	L-side		
SD	Plug for rotary engines (Semi-surface discharge gap)	6				-T	T-side	
		7						
		8						
		9						
		10						
		11						

HB		6		A				IX	-11		P	
		Heat Rating		Thread Dimensions / Hex. Size						Spark Gap		
HB	HYBD® (3-ground-electrode hybrid type)	4	Hot type ↑ ↓ Cold type	A	ø14.0	20.5mm	Gasket	Hex 16.0	IX	-8	0.8mm	
		5		B	ø14.0	19.0mm	Gasket	Hex 16.0		-9	0.9mm	
		6								-10	1.0mm	
		7								-11	1.1mm	
		8								-13	1.3mm	

DF		6		H				-11		A	
		Heat Rating		Thread Dimensions / Hex. Size				Spark Gap			
DF	High ignitability plug: Double fine electrodes	4	Hot type ↑ ↓ Cold type	A	ø14.0	19.0mm	Gasket	Hex 16.0	-8	0.8mm	A,B,C...Suffix code
DFH	High ignitability plug: Double fine electrodes + 3-ground-electrode hybrid type	5		B	ø14.0	26.5mm	Gasket	Hex 16.0	-9	0.9mm	
		6		H	ø12.0	26.5mm	Gasket	Hex 14.0	-10	1.0mm	
		7		*DF6H-11A: Thread reach 28.0mm				-11	1.1mm		
		8						-13	1.3mm		
		9						-15	1.5mm		

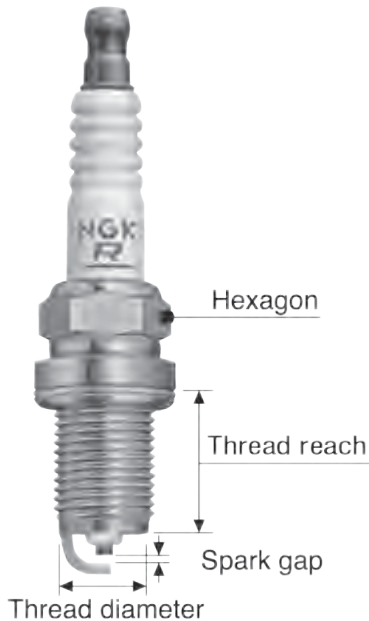

Please Note: Not all configurations are carried in Australia. Please check with your distributor.

PART NUMBER IDENTIFICATION SPARK PLUG RESISTOR CAPS

L B 05 E P K -R

External appearance	
L	90° ø Elbow type
S	Straight
X	102° ø Elbow type
V	102° ø Elbow type (long)
Y	102° ø Elbow type (short)
T	T type

Resistance	
None	No resistor
01	1K Ω
05	5K Ω
10	10K Ω

Accessory	
A	Special design
H	Compact type
P	With special waterproof cover
K	With silicon waterproof cover
M	Rubber sheathed
G	With rubber grommet
W	Double connector springs
F	For 5mm ø cable
L	Inductive resistor type
Y	With handle
Z	Special shape
C	Cable

Adaptable plug thread size	
B	14mm ø thread
C	10mm ø thread CM-6 only
D	10 & 12mm ø thread
Z	10, 12 & 14mm ø thread

Adaptable plug terminal	
E	For terminal nut or solid post terminal
F	For terminal stud or threaded terminal

Plug cap colour	
-B	Blue
-G	Green
-R	Red
-Y	Yellow
None	Black

C R 1

Cable

Colour Red

	Cover configuration	Adaptable plug terminal	Cable length
1	Straight cover	For terminal stud	500mm
2	90° cover	For terminal stud	500mm
3	Straight cover	For integrated terminal	500mm
4	90° cover	For integrated terminal	500mm
5	90° cover	For terminal stud	1,000mm
6	90° cover	For integrated terminal	1,000mm

Please Note: Not all configurations are carried in Australia. Please check with your distributor.



NOTES

PLATINUM

DURABILITY

FUTURE

TECH

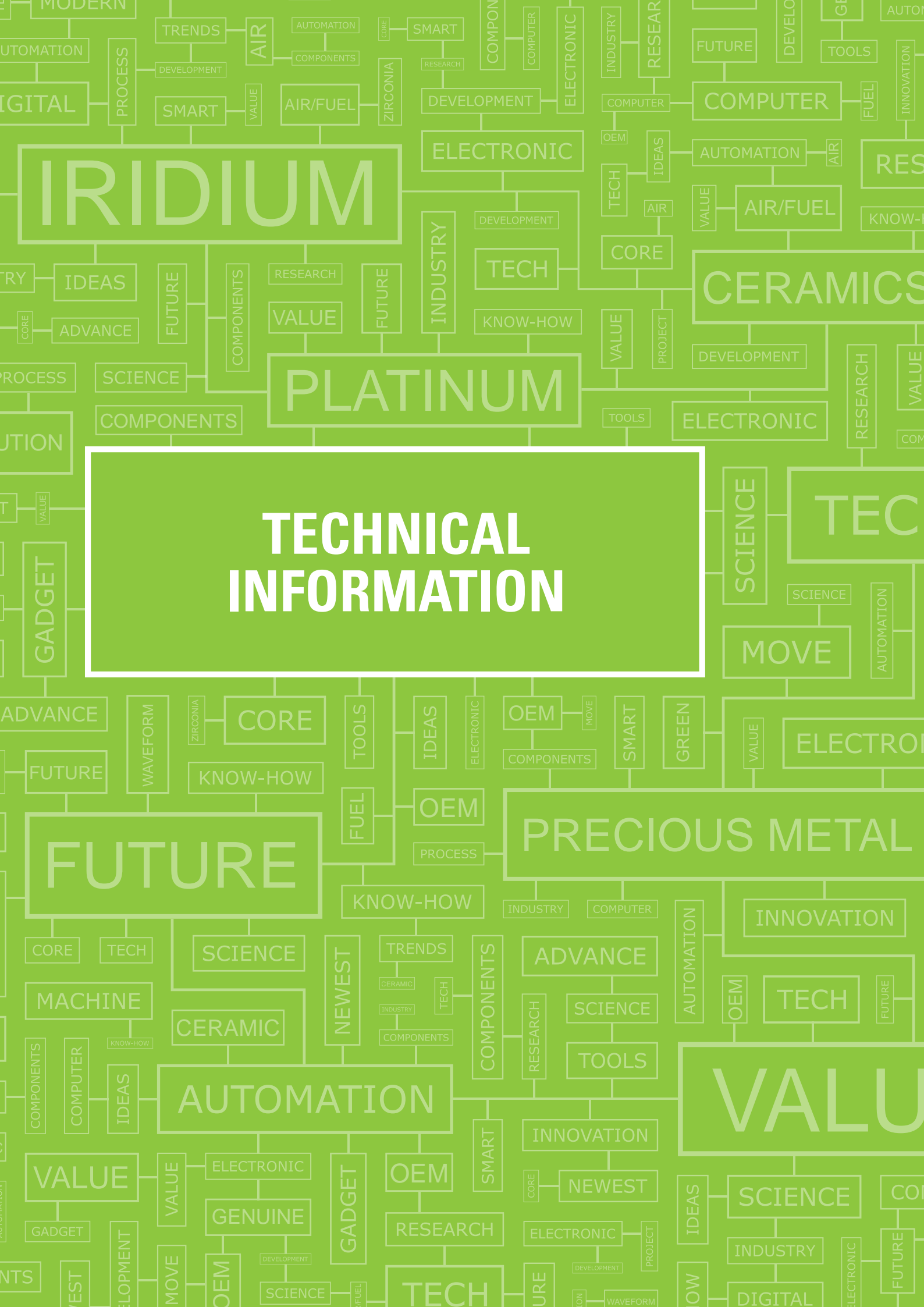

TECHNICAL INFORMATION



TECHNICAL INFORMATION SPARK PLUGS – INSTALLATION INSTRUCTIONS

Selection

Although many spark plugs with similar part numbers may look the same, each plug has its own characteristics, with some changes not physically visible. These differences are imperative to the operation of the engine and straying from the recommended plug can result in some loss of performance (best case) or severe engine damage (worst case). It's recommended you use the most current NGK Australian or New Zealand catalogue to find the correct part number listed for your vehicle (unless modified) or visit www.ngk.com.au or www.ngkspark.co.nz

Preparation

Before installing the spark plug make sure the engine is cool and the plug ports are clear of any debris or dirt. This will help for easy removal of the spark plugs.

Installation

When installing, firstly tighten the spark plug so it is finger tight; the gasket or taper seat should just be touching the cylinder head (to ensure the plug thread is not damaged by cross thread) (See Figure 4). Then use a plug wrench to tighten fully. Recommended tightening torques are shown below. Looseness can sometimes cause pre-ignition because the heat cannot escape. On the other hand, excessive tightness can damage the threads of both the cylinder head and spark plug. (See Figure 3)

TORQUE SETTING SPECIFICATIONS

Spark Plug Type (thread diameter)		Cast Iron Cylinder Head	Aluminium Cylinder Head
Flat Seat Type (with gasket)	18mmØ	35 ~ 45 Nm (25.3 ~ 32.5 lb-ft)	35 ~ 40 Nm (25.3 ~ 28.9 lb-ft)
	14mmØ	25 ~ 35 Nm (18.0 ~ 25.3 lb-ft)	25 ~ 30 Nm (18.0 ~ 21.6 lb-ft)
	12mmØ	15 ~ 25 Nm (10.8 ~ 18.0 lb-ft)	15 ~ 20 Nm (10.8 ~ 14.5 lb-ft)
	10mmØ	10 ~ 15 Nm (7.2 ~ 10.8 lb-ft)	10 ~ 12 Nm (7.2 ~ 8.7 lb-ft)
Conical Seat Type (without gasket)	18mmØ	20 ~ 30 Nm (14.5 ~ 21.6 lb-ft)	20 ~ 30 Nm (14.5 ~ 21.6 lb-ft)
	14mmØ	15 ~ 25 Nm (10.8 ~ 18.0 lb-ft)	10 ~ 20 Nm (7.2 ~ 14.5 lb-ft)

Alternatively, the spark plugs irrespective of size can be finger tightened, and then fully tightened using a plug wrench to the angle shown in the table below. This will ensure the plug is neither under or over tightened.

RECOMMENDED TIGHTENING ANGLES







Spark Plug Thread Size		New Gasket	Used Gasket
18mm & 14mm (except ▼)		1/2 to 2/3 turn (180 to 240 degrees)	1/12 turn (30 degrees)
BCPR6ED	BKR6EKE	1/3 turn (120 degrees)	1/12 turn (30 degrees)
BCPR6EKD	BKR5ETUA		
BCPR7EKD	HB6AIX-11P		
BCPR7EDIX	HB6BIX-11P		
BKR5EKUC	IZFR5C		
BKR5EKUD	PZFR5C		
BKR6EKUC	R6469-9		
BKR6EKUD	R6918C-9		
12mm (except ▼)		1/2 turn (180 degrees)	1/12 turn (30 degrees)
DILZKR7A11GS	SILKR8A-S	1/4 turn (90 degrees)	1/8 turn (45 degrees)
DILZKR7B11GS	R2556B-○		
ILZKR7B11GS	R2558A-○		
ILZKR7B-11S			
10mm (except ▼)		1/2 turn (180 degrees)	1/12 turn (30 degrees)
CPR6EA-9S	MAR9B-JDS	1/6 turn (60 degrees)	1/12 turn (30 degrees)
CPR7EA-9S	MR8AP8HJS		
CR8EH-9S	SILMAR9A9S		
CR9EH-9S	SILMAR10A9S		
IMR8C-9HES	SILR6A7S		
IMR9C-9HES	SILR7A7S		
IMR9D-9H	SPMR8A6HDG		
IMR9E-9HES	R0409B-○		
LMAR8A-9S	R0451B-8		
MAR8B-JDS	R0465B-10		
8mm (Standard steel gasket)		1/3 turn (120 degrees)	1/12 turn (30 degrees)
Conical seat type - No gasket		1/16 turn (22.5 degrees)	1/16 turn (22.5 degrees)
Copper gasket		1/12 turn (30 degrees)	1/24 turn (15 degrees)

Plug Socket Troubles

Damage to spark plugs during installation can easily occur and will often result in an intermittent misfire or no spark at all. Care must be taken during installation that the spark plug socket is not slanted and does not slip causing insulator breakage. (See Figure 1). Internal damage can still occur without the insulator actually breaking. Any horizontal force can either bend the terminal post internally or result in internal cracking of the insulator.

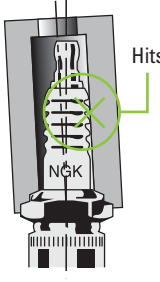
To avoid plug damage the following qualities are required in a wrench (See Figure 2);

1. That it fits the spark plug "hex" properly.
2. The inner space must be large enough to avoid contact with the insulator.
3. The spark plug socket must completely cover the "hex" portion of the metal shell.
4. A hexagonal socket is preferable as it is less likely to slip than a twelve point star type.

Figure 1	Figure 2	Figure 3	Figure 4
Cracked insulator	Examples of bad spark plug wrench usage	Metal shell damage	Thread damage from installation
<p>Damage to the caulked portion</p>  <p>Damage at the corrugation</p> 		<p>Damage to the caulked portion</p>  <p>Damage to the threads</p> 	<p>Damage to the ridges of the first and second threads</p> 
Spark plug wrench slipped or used at an angle.		Excessive tightening torque.	Spark plug is inserted at an angle during installation.
Use a hex-type wrench that is less likely to slip.		Tighten to recommended Torque.	Do not use the wrench at first. Start by installing the spark plug by hand.



QUICK INSTALLATION CHECKLIST

<p>Step 1</p> <p>Confirm that the part number and specifications of the Spark Plug are correct for your engine.</p>	<p>Step 4</p> <p>Tighten the Spark Plug finger tight until the gasket reaches the cylinder head, then tighten 1/2 - 2/3 turn further with a Spark Plug wrench. (Conical Seat: approx 1/16 turn more). Refer to diagrams below.</p>
<p>Step 2</p> <p>Check the thread reach and electrode gap on each plug prior to installation. Ensure the electrode gap sizes are consistent and set to manufacturer's recommendations.</p>	<p>Step 5</p> <p>If using a torque wrench, refer to the torque setting table specifications. (Refer to page 10)</p>
<p>Step 3</p> <p>Remove any dirt or grime from the gasket seat of the cylinder head.</p>	<p>Step 6</p> <p>Removal and installation should only be performed when the engine is cool.</p>

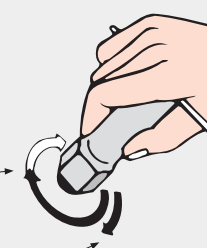
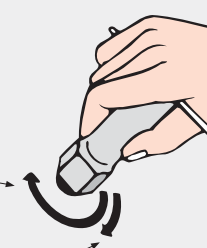
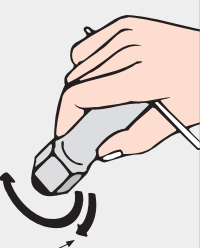

TECHNICAL INFORMATION SPARK PLUGS – INSTALLATION INSTRUCTIONS

RECOMMENDED TIGHTENING ANGLES

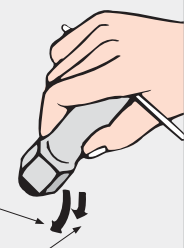
18mm & 14mm thread diameter	12mm thread diameter	10mm thread diameter
 <p>NEW PLUGS (EXCEPT ▼) $\frac{1}{2} \sim \frac{2}{3}$ TURN (180°~240°)</p> <p>REUSED (EXCEPT ▼) $\frac{1}{12}$ TURN (30°)</p> <p>INCASE ▼ NEW PLUGS REUSED $\frac{1}{3}$ TURN (120°) $\frac{1}{12}$ TURN (30°)</p>	 <p>NEW PLUGS (EXCEPT ▼) $\frac{1}{2}$ TURN (180°)</p> <p>REUSED (EXCEPT ▼) $\frac{1}{12}$ TURN (30°)</p> <p>INCASE ▼ NEW PLUGS REUSED $\frac{1}{4}$ TURN (90°) $\frac{1}{8}$ TURN (45°)</p>	 <p>NEW PLUGS (EXCEPT ▼) $\frac{1}{2}$ TURN (180°)</p> <p>REUSED (EXCEPT ▼) $\frac{1}{12}$ TURN (30°)</p> <p>INCASE ▼ NEW PLUGS REUSED $\frac{1}{6}$ TURN (60°) $\frac{1}{12}$ TURN (30°)</p>
8mm thread diameter (Standard steel gasket)	8mm thread diameter (Conical seat type - no gasket)	8mm thread diameter (Copper gasket)
 <p>NEW PLUGS $\frac{1}{3}$ TURN (120°)</p> <p>REUSED $\frac{1}{12}$ TURN (30°)</p>	 <p>NEW PLUGS OR REUSED $\frac{1}{16}$ TURN (22.5°)</p>	 <p>NEW PLUGS $\frac{1}{12}$ TURN (30°)</p> <p>REUSED $\frac{1}{24}$ TURN (15°)</p>



DFE (Double Fine Electrode) Spark Plugs

As emission regulations continue to become more stringent, pressure on car manufacturer's to reduce emissions and improve efficiency has increased. NGK work closely with over 50 engine manufacturers worldwide, assisting with compliance to regulations by developing the Double Fine Electrode (DFE) Spark Plug. The key features of this Spark Plug include:

- **ULTRA HIGH IGNITABILITY**
Achieved via fine tipped centre and ground electrodes.
- **SUPERIOR SERVICE LIFE**
NGK DFE Spark Plugs are manufactured with Iridium centre and Platinum ground electrodes for the longest possible service life.

NGK are at the forefront of Spark Plug technology with Iridium and Platinum Spark Plugs and continue to raise the benchmark in Spark Plug technology and quality by offering Double Fine Electrode Spark Plugs.

Note: Please be aware that DFE Spark Plugs are manufactured in accordance with OE requirements. As such, only a limited range is currently available to suit specific applications.



Bi-Hex Spark Plugs

As modern engines become more efficient and compact, engine components such as Spark Plugs are required to become smaller too. NGK have recognised this and assisted by developing Bi-Hex Spark Plugs.

Traditionally, Spark Plugs have been designed with a hexagonal socket style (See image Below). The Bi-Hex design provides increased strength compared to a traditional hexagon design, allowing for a more compact Spark Plug without compromising strength requirements

Currently there are only the following limited Original Equipment applications suitable for some Mini Cooper, Cooper S and BMW's:

- PLZKBR7A-G



Precious Metal Spark Plugs

In recent years NGK Spark Plugs have developed a range of precious metal Spark Plugs that provide two major benefits over conventional Spark Plugs:

- **High Ignitability** – is only achieved by utilising an exposed fine tip centre electrode allowing for superior flame growth.
- **Long Service Life** – is achieved by utilising a high percentage of precious metals patented by NGK.

As emission laws become more stringent, the performance expectations of Spark Plugs also increase. NGK have developed a range of Iridium and Platinum Spark Plugs to meet and surpass the modern requirements of vehicle manufacturers.

Precious metals such as Iridium and Platinum have much higher melting points over traditional metals such as Nickel.

- Iridium – 2410°C
- Platinum – 1772°C
- Nickel – 1453°C

This allows centre electrode diameters to reduce from 2.5mm using Nickel, to 0.6mm using Iridium or Platinum. The finer point means that once a spark forms, the flame kernel does not have a large mass of centre electrode that reduces absorption of heat and the flame shadow impeding the flame progress. This equates to a more complete burn that translates to:

- Improved acceleration
- Improved fuel consumption
- Smoother idling

The fine centre electrode of precious metal spark plugs increases the electric field strength at the gap, reducing the voltage required for sparking to begin. **NGK DO NOT RECOMMEND ADJUSTING THE GAPS ON PRECIOUS METAL PLUGS.**



NORMAL	NORMAL WEAR	ABNORMAL EROSION	RAPID ABNORMAL EROSION
			
<p>Insulator nose has slight deposits. Colour ranges from brown to greyish-white. Spark plug is functioning correctly under good engine conditions.</p>	<p>The centre and/or ground electrodes are worn. Deposits cover the insulator nose and ground electrodes. The plug has operated under normal conditions for a considerable period and reached the end of its life. Further usage will cause misfire, bad fuel economy and poor engine performance.</p>	<p>The centre and/or ground electrodes badly worn relative to the length of operation. Misfire will eventually result due to the high ignition voltage needed for the large gap. Abnormal erosion is often caused by harsh lead oil additives combined with severe operating conditions such as high speed driving.</p>	<p>The centre and/or ground electrodes are very badly worn. Their surfaces are fretted and rough. The electrodes have oxidised and sometimes turn green when the oxidation is heavy. Rapid abnormal erosion is produced by a more aggressive operating environment than "Abnormal Erosion". Refer to "Abnormal Erosion" for causes.</p>
INSULATOR BREAKAGE	MELTED	OVERHEATED	DEPOSITS (ASH FORMATION)
			
<p>The Insulator nose is cracked or split. Breakage not resulting from mechanical impact is caused by sudden heating or cooling (thermal shock). Severe detonation will often produce the type of breakage shown in the picture. Causes of detonation are similar to what is described in "Overheated."</p>	<p>The centre and/or ground electrodes surface in uneven and cauliflower like in appearance. The insulator is blistered and possibly contains metallic deposits. Melting fire ends results from overheating. Refer to "Overheating" for causes.</p>	<p>Overheated spark plugs have a white glazed or glossy insulator. Small black deposits accumulate on the insulator nose and the electrodes are prematurely worn. Causes of overheating include; over-advanced ignition timing, lean fuel mixture, insufficient fuel octane rating, excessive deposits accumulated in combustion chamber, manifold air leak, insufficient cooling and lubricating, spark plug heat rating is too hot.</p>	<p>Heavy ash deposits build-up on the firing end and eventually cause misfire. In some circumstances these deposits can reach temperatures which might lead to pre-ignition. Ash formation is mainly produced from the burning of oil, type of oil, fuel additives and engine condition.</p>
OIL FOULING	CARBON FOULING	LEAD EROSION	LEAD FOULING
			
<p>Wet, black, oily, carbon deposits form on the insulator nose and electrodes. As described in "Carbon Fouling", misfire results due to the reduction in insulation resistance between centre and ground electrodes. Causes of oil fouling include; excessive oil entering into combustion chamber, oil level is too high, worn piston rings, cylinders and valve guides.</p>	<p>Dry, soft, black carbon deposits form in large quantities on the insulator nose and electrodes. As carbon accumulates the insulation between the centre and the ground electrodes deteriorates, an electrical leakage path is formed by the carbon and misfire results. Causes of carbon fouling included; rich fuel mixture, clogged air filter, faulty choke system, prolonged low speed driving or idling, faulty ignition system, over-retarded ignition timing and spark plug heat rating is too cold.</p>	<p>The ground electrodes are badly worn and appears to be chipped. Lead erosion is caused by the harsh lead additives in the fuel. At high temperatures these additives chemically react with the nickel alloy electrodes and separate the grain boundary of the nickel alloy.</p>	<p>Lead fouling usually appears as yellowish brown deposits on the insulator nose. The lead deposits have no adverse effect on starting, idling or low speed driving, but do cause misfire during rapid acceleration or under heavy engine load. Misfire results when the lead deposits become electrically conductive at high temperatures creating a reduction in the insulating resistance between centre and ground electrodes. The lead additives used to enhance the fuel octane rating are the source of lead deposits. Lead fouling will not occur with unleaded fuel.</p>

Carbon Fouling

Carbon fouling accounts for around 90% of all Spark Plug troubles. During combustion of the air/fuel mixture, carbon deposits can build up on the firing end of the insulator nose. As these deposits accumulate, a conductive path is formed from the centre electrode, down the insulator nose to where the insulator meets the metal shell. This build-up provides a path for the electrical current to leak through. When voltage is applied, under certain conditions, the carbon path may drain enough current so as to prevent sufficient voltage to build up at the gap, and misfire occurs. This leakage path is shown in Figure 1.

NGK Spark Plug designs incorporate a number of features to combat carbon fouling. Some design examples are the semi-surface discharge, supplementary gap, longer insulator nose, and extended shell. Spark Plug anti-fouling design features are called on by the engine manufacturer, as required during the design and development stage of new engines. With standard vehicles, the recommended plug should be used and if fouling is a problem, a check on the engine conditions as outlined in the table below should be made.

The most effective property of a Spark Plug to prevent fouling is its ability to self clean. Self cleaning is the term used to describe the burning of carbon deposits off the insulator nose when the cylinder temperatures rise above approximately 450°C. Depending on the vehicle, self cleaning will only occur at speeds above approximately 50km/h. During times of prolonged idling and low speed driving the engine temperature is relatively low and carbon deposits may start building up on the insulator nose. On the other hand, highway and high speed driving increase the cylinder temperature enough for the carbon deposits to be burnt away and self cleaning occurs.

Figure 1

Note: During operation, water, oil and fuel molecules can adhere to the carbon deposits and increase the conductivity of the carbon leakage path.

It is important to note that Spark Plugs do not produce carbon deposits. If the recommended plug is being used and there is still fouling problems the following should be checked.

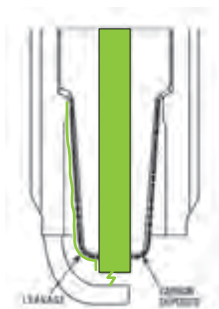

Possible Causes of Carbon Fouling	Explanation
Rich Fuel Mixture	If the air/fuel mixture is rich, combustion is not complete which can result in carbon being deposited on the insulator nose. Due to this excess fuel, the insulator nose is also kept at a lower temperature and existing carbon has less chance of being burnt off.
Excessive Lubrication Oil Entering Into The Combustion Chamber	Any oil entering the combustion chamber can build-up on the insulator nose due to high compression and heat.
Clogged Air Filter	If the air filter is clogged, the intake will not draw enough air for complete combustion and carbon deposits can accumulate.
Weak/Deteriorated Ignition Components	This can be any component in the ignition system that may have deteriorated such as the coil, leads, caps, etc. Anything that has the effect of reducing spark energy may be at fault. If spark energy is lowered, misfire can occur and carbon will build-up on the insulator.
Too Cold A Spark Plug	If the plug selected is too cold, its operating temperature may not be sufficiently high to accommodate self-cleaning, in which case carbon fouling is likely to occur.
Over-Retarded Ignition System	If the ignition system is retarded then there is less compression in the cylinder, resulting in a lower operating temperature. This can result in carbon build-up because the plug may not reach its self-cleaning temperature.
Prolonged Low Speed Driving or Idling	The engine needs to be at a sufficient operating temperature to achieve self-cleaning. During idling, engine temperatures drop below the required 450°C for self cleaning.

Other Types of Fouling – Fuel Additives

This is where fuel additives are mixed into a normal tank of fuel to combat various engine problems, such as clogged injectors, etc. These additives can sometimes adhere to the firing end of the plug. Under high compression and excessive heat these additives can become conductive and result in misfire.

Lead Fouling

When lead contained in petrol (as an octane enhancer) adheres to the firing end of a Spark Plug, it can create a leakage path as in carbon fouling. This is called lead fouling. Lead fouling may not become apparent until accelerating from a middle range speed.



NOTES



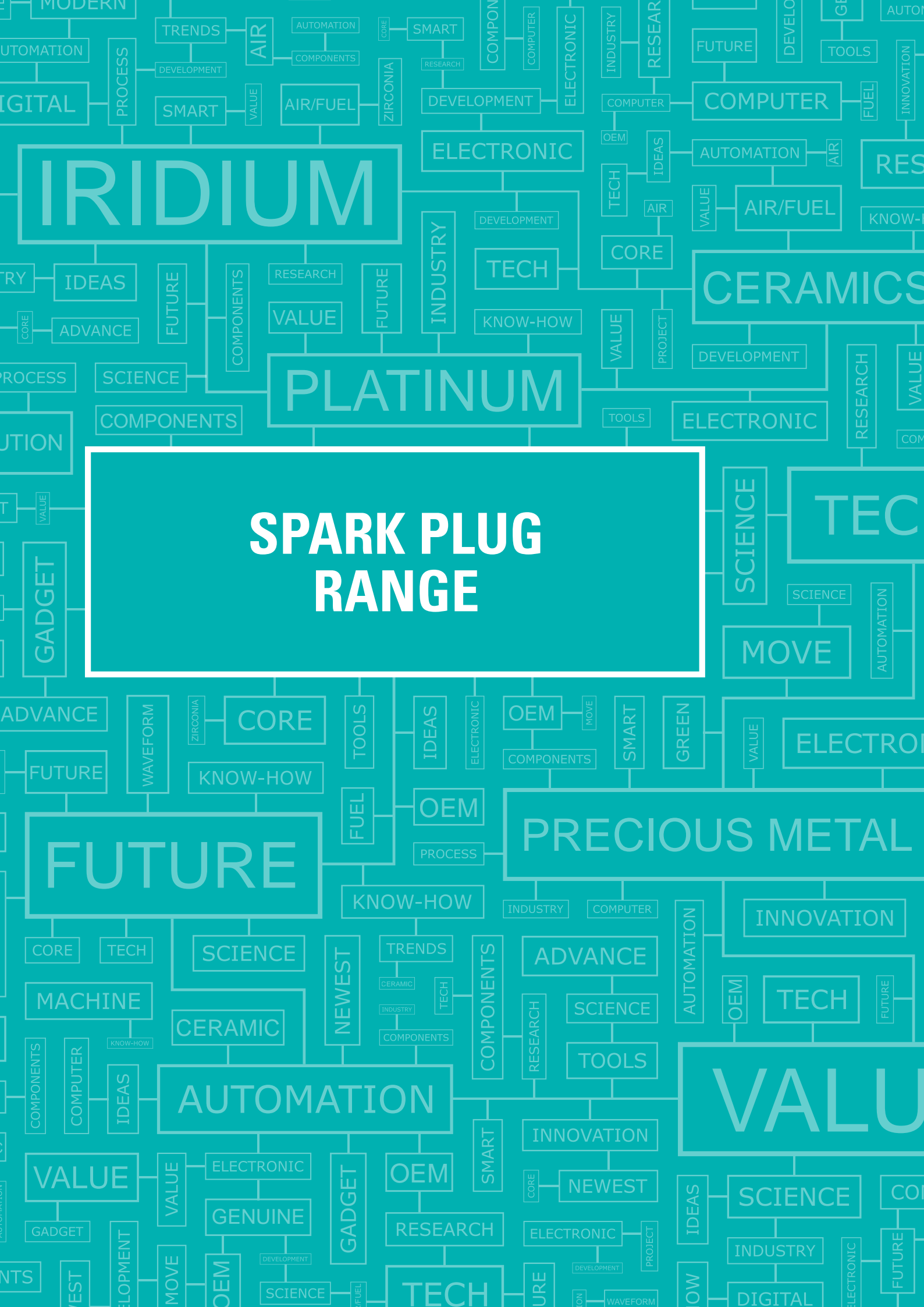

IRIDIUM

PLATINUM

CERAMICS

TEC

PRECIOUS METAL

FUTURE

VALU

AUTOMATION

VALUE

TECH

SPARK PLUG RANGE



SPARK PLUG RANGE

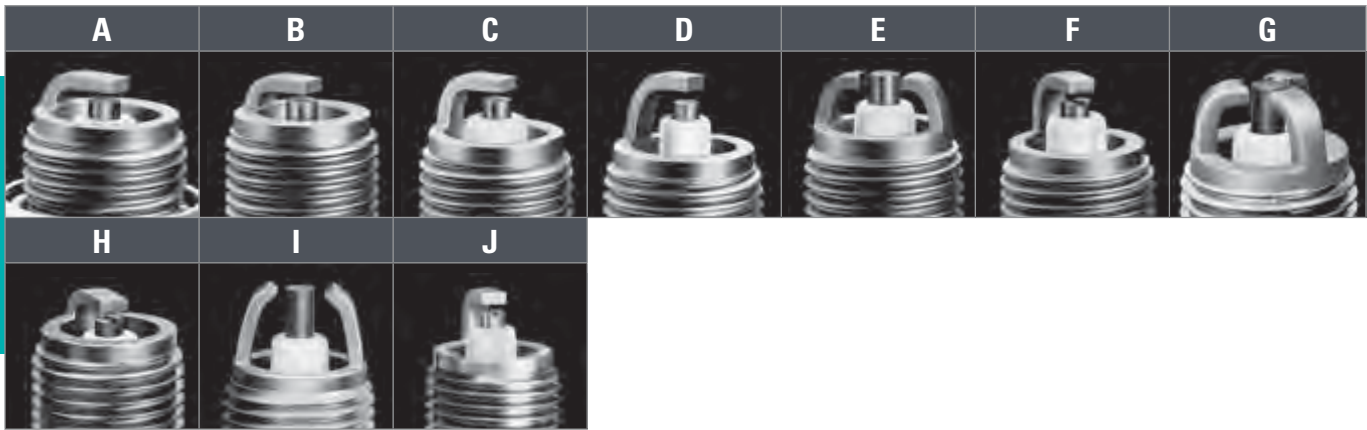
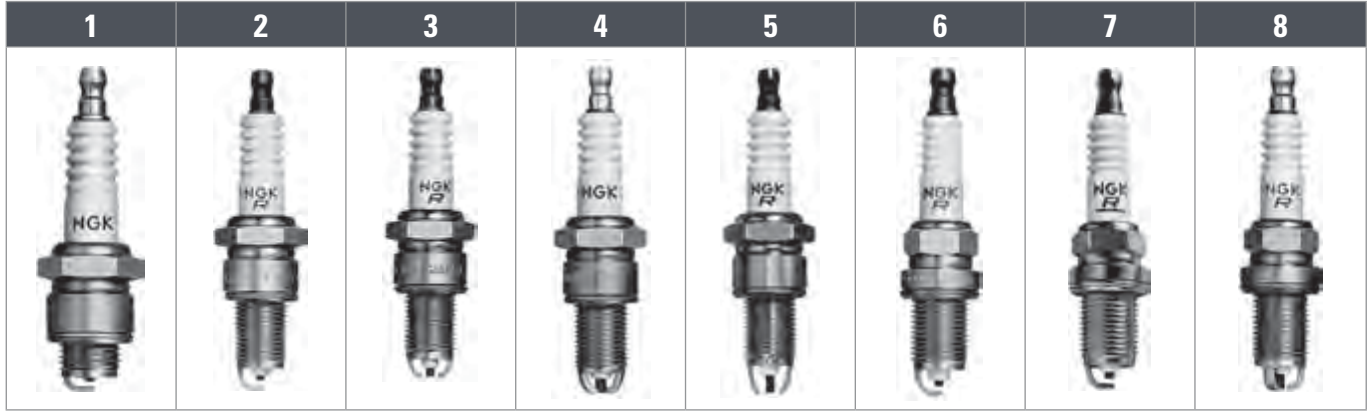

STANDARD TYPES				
Fig	End	ISO	Non-Resistor	Resistor
14mmØ x 9.5mm 20.8 Hex				
1	A		B-2 B-4 B6S B7S B8S	BR6S
1	C		BP-4 BP5S BP6S R5670-7 (BP7S)	
14mmØ x 19.0mm 20.8 Hex				
2	A		B4ES B5ES B6ES, -11 B7ES, -11 B8ES B9ES B10ES	BR4ES BR5ES BR6ES, -11 BR7ES BR8ES, -11 BR9ES BR10ES
2	B			BR6EB-L-11
2	H			BR8EYA BR9EYA BR10EYA
2	C		BP2ES, BP-2E BP4ES, -11 BP4ES-L-11 BP5ES, -11, -13 BP6ES, -11 BP7ES, -11 BP8ES BP9ES	BPR2ES, BPR-2E BPR4ES, -11, -13 BPR5ES, -11, -13 BPR6ES, -11, -13 BPR7ES, -11 BPR8ES BPR9ES
2	D			BPR5EA BPR5EA-L, -11
3	E			BPR6EKN BPR7EKN

STANDARD TYPES				
Fig	End	ISO	Non-Resistor	Resistor
14mmØ x 19.0mm 20.8 Hex (cont)				
2	F		BP4EY, -11 BP5EY, -11 BP6EY, -11 BP7EY	BPR4EY, -11 BPR5EY, -11 BPR6EY, -11 BPR7EY, -11
2	J		BP5E BP6E	BPR4E, -11 BPR5E, -11 BPR6E, -11 BPR7E
4	G		BP5ET, -10 BP6ET BP7ET	
5	I			BPR5EJ
14mmØ x 19.0mm 16.0 Hex				
6	C		BCP4ES, -11 BCP5ES, -11 BCP6ES, -11 BCP7ES, -11 R5672A-8 (BCP8E) R5672A-9 (BCP9E) R5672A-10 (BCP10E)	BCPR4ES, -11 BCPR5ES, -11 BCPR6ES, -11 BCPR7ES, -11 BCPR9ES-11
8	G	ISO	BCP5ET BCP6ET BCP7ET	BCPR5ET BCPR6ET BCPR7ET
6	A		BC6ES R5671A-7 (BC7E) R5671A-8 (BC8E) R5671A-9 (BC9E) R5671A-10 (BC10E)	BCR8ES
7	C	ISO	BK5ES	BK5ESZ BKR4ES, -11 BKR5ES, -11 BKR6ES, -11 BKR7ES-11



STANDARD TYPES				
Fig	End	ISO	Non-Resistor	Resistor
14mmØ x 19.0mm 16.0 Hex				
1	C		BCP5EY-11	BCPR4EY-11 BCPR5EY,-11,-N-11 BCPR6EY,-11,-N-11 BCPR7EY,-11,-N-11
2	C	ISO		BKR4EY,-11 BKR5EY,-11 BKR5EYA,-11 BKR6EY,-11 BKR6EYA,-11 BKR7EY
1	D		BCP5E,-11 BCP6E,-11 BCP7E,-11	BCPR5E,-11 BCPR6E,-11 BCPR7E,-11
2	D	ISO	BK5E,-11 BK6E,-11	BKR4E,-11 BKR5E,-11,-N,-N-11 BKR5EZ BKR6E,-11,-N,-N-11 BKR6EZ BKR7E,-11,-N-11 BKR8E,-11
6	F	ISO		BKR5EK BKR6EK
6	G	ISO		BKR5EKB-11 BKR6EKB-11 BKR5EKC BKR6EKC,-N-11 BKR6EKE BKR7EKC,-N,-N-11
14mmØ x 26.5mm 16.0 Hex				
8	D			LFR4A,-11 LFR5A,-11 LFR6A,-11
14mmØ x 11.2mm 16.0 Hex - Conical seat				
3	A		B7FS R5673-7 (B7F) R5673-8 (B8F) R5673-9 (B9F) R5673-10 (B10F)	BR5FS BR6FS,-15

STANDARD TYPES				
Fig	End	ISO	Non-Resistor	Resistor
14mmØ x 11.2mm 16.0 Hex - Conical seat (cont)				
3	B		BP4FS BP5FS BP6FS BP7FS R5674-7 (BP7F) R5674-8 (BP8F) R5674-9 (BP9F) R5674-10 (BP10F)	BPR4FS,-11,-15 BPR5FS,-11,-15 BPR6FS
3	D		BP5F BP6F	
14mmØ x 17.5mm 16.0 Hex - Conical seat				
4	A		B6EFS B8EFS B9EFS	BR7EFS
4	E			BR6EF BR7EF
4	B		BP4EFS BP5EFS,-13 BP6EFS,-13 BP7EFS R5724-8 (BP8EF) R5724-9 (BP9EF) R5724-10 (BP10EF)	BPR5EFS,-13 BPR6EFS,-13,-15 BPR7EFS-15
4	D		BP6EF	BPR6EF,-11,-13
14mmØ x 25.0mm 16.0 Hex - Conical seat				
7	B			TR5A-13 TR5B-13 TR6B-10,-13
14mmØ x 11.2mm 20.8 Hex				
5	A		B-4L B-6L B6LY (Fig. 5E)	



SPARK PLUG RANGE

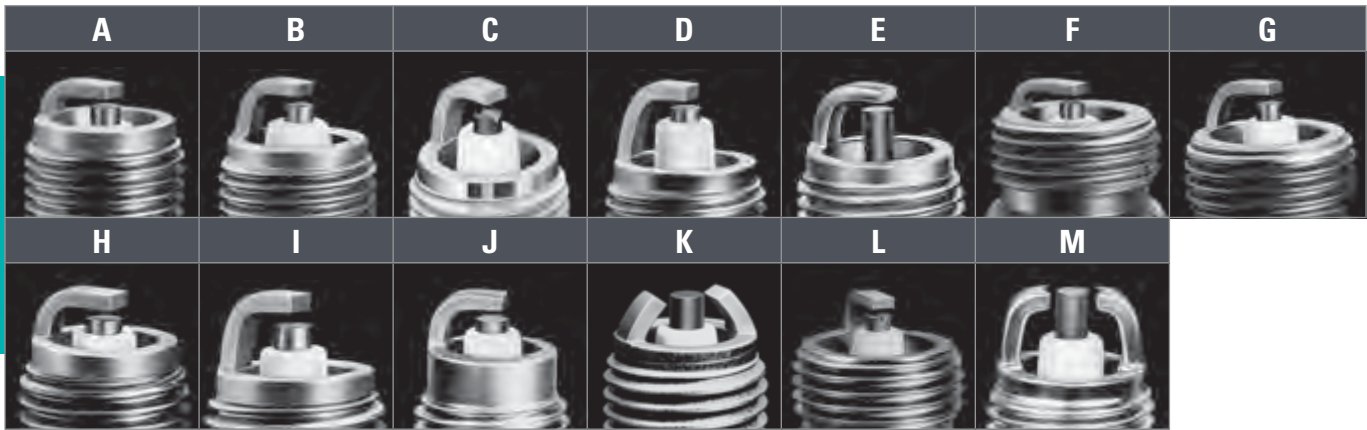

STANDARD TYPES				
Fig	End	ISO	Non-Resistor	Resistor
14mmØ x 12.7mm 20.8 Hex				
1	A		B-2H B-4H,-10 B5HS B6HS,-10 B7HS,-10 B8HS,-10 B9HS,-10 B10HS	BR4HS BR5HS BR6HS,-10 BR7HS,-10 BR8HS,-10 BR9HS,-10 BZ7HS-10
1	B		BP2HS,-10 BP-2H BP4HS,-10 BP4HSA BP-4H BP5HS,-10 BP6HS,-10 BP6HSA BP6H BP7HS,-10 BP7H BP8HS,-10,-15 BP8HSA	BPR2HS BPR4HS,-10 BPR4HSA BPR-4H BPR5HS BPR6HS,-10 BPR6HSA BPR7HS,-10 BPR8HS,-10 BPR8HSA BPZ8HS,-10,-15
1	C		BP4HA BP5HA	
1	E		B6HSA B8HSA	BR4HSA,-9 BR6HSA,-9 BR8HSA,-9
18mmØ x 10.9mm 20.8 Hex - Conical seat				
4	F		A6FS A7FS A8FS A9FS	AR6FS
4	G		AP4FS AP5FS AP6FS AP7FS AP8FS AP9FS	APR5FS APR6FS
4	L		AP6F	APR6F

STANDARD TYPES				
Fig	End	ISO	Non-Resistor	Resistor
18mmØ x 12.0mm 20.8 Hex				
5	F		AB-2 AB-6 AB-7 AB-8	
12mmØ x 19.0mm 18.0 Hex				
6	H		D6EA D7EA D8EA D9EA D10EA	DR7EA DR7EB DR8EA DR8EB DR9EA
6	I		DP6EA-9 DP7EA-9 DP8EA-9 DP9EA-9	DPR5EA-9 DPR6EA-9 DPR6EB-9 DPR7EA-9 DPR8EA-9 DPR9EA-9
6	H		J9A	JR8B JR9B JR10B
6	K			JR8C JR9C
12mmØ x 21.0mm 18.0 Hex				
7	J		DP8Z	DPR7Z DPR8Z DPR9Z
12mmØ x 19.0mm 16.0 Hex				
8	I		DCP6E DCP7E	DCPR6E DCPR7E DCPR7E-N DCPR8E DCPR8E-N DCPR9E
8	M			DCPR8EK
12mmØ x 26.5mm 14.0 Hex				
				LKAR8A-9,9S

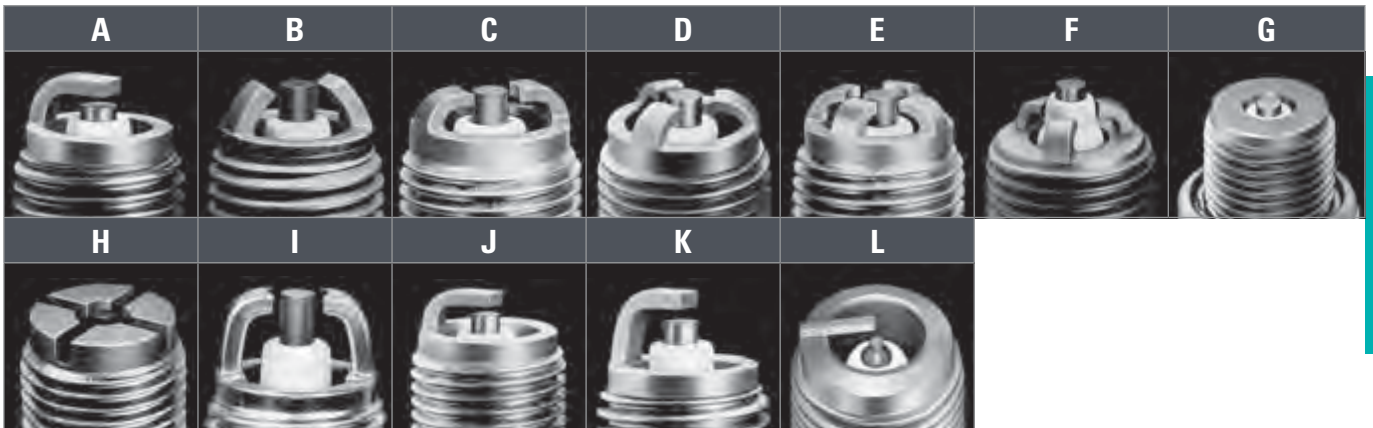
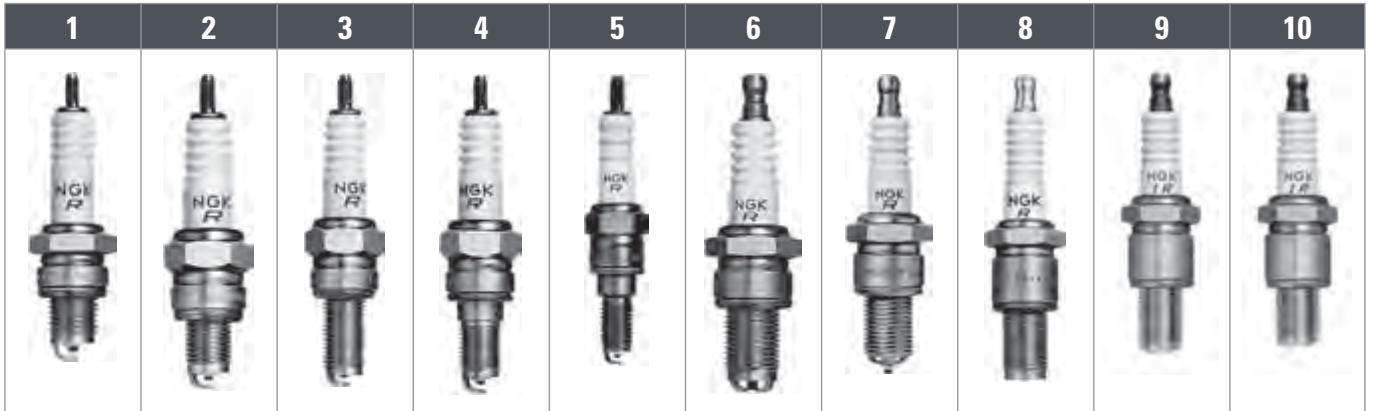

STANDARD TYPES					
Fig	End	ISO	Non-Resistor	Resistor	
12mmØ x 12.7mm 18.0 Hex					
1	A		D6HA D8HA	DR4HS DR5HS DR6HS DR8HS	
10mmØ x 12.7mm 16.0 Hex					
2	A		C2H C5HSA C6HSA C7HSA C8HSA	C4HSB C5HSB	CR4HSA CR5HSA CR6HSA CR7HSA CR8HSA
10mmØ x 19.0mm 16.0 Hex					
3	J		C7E C8E C9E	CR6E CR7E CR8E CR9E CR10E	
3	K			CPR8E	CPR7EA-9
4	A		C7EH-9 C8EH-9 C9EH-9	CR7EH-9 CR8EH-9 CR9EH-9 CR10EH-9	
3	B			CR7EK CR8EK CR9EK CR10EK	CR7EKB CR8EKB CR9EKB
3	I			CR7EKC	
10mmØ x 19.0mm 14.0 Hex					
				MAR10A-J	
10mmØ x 26.5mm 14.0 Hex					
				LMAR6A-9 LMAR6C-9 LMAR7A-9 LMAR8A-9,9S	

STANDARD TYPES					
Fig	End	ISO	Non-Resistor	Resistor	
8mmØ x 19.0mm 13.0 Hex					
5	A			ER8EH ER9EH ER10EH	

ROTARY ENGINES					
Fig	End	ISO	Non-Resistor	Resistor	
14mmØ x 19.5mm 20.8 Hex					
6	C	ISO	B7EM	BR8EM	
6	D	ISO		BR7ET BR8ET BR9ET BR10ET	
6	E	ISO		BR7EQ-14 BR8EQ-14 BR9EQ-14	
14mmØ x 21.5mm 20.8 Hex					
8	G			SD10A SD11A	
8	H			BUR6EQ BUR7EQ BUR7EQP BUR8EQ BUR9EQ BUR9EQP	
14mmØ x 21.0mm 20.8 Hex					
9				RE6C-L RE7C-L RE8C-L	
14mmØ x 19.0mm 20.8 Hex					
10	L			RE9B-T	



SPARK PLUG RANGE

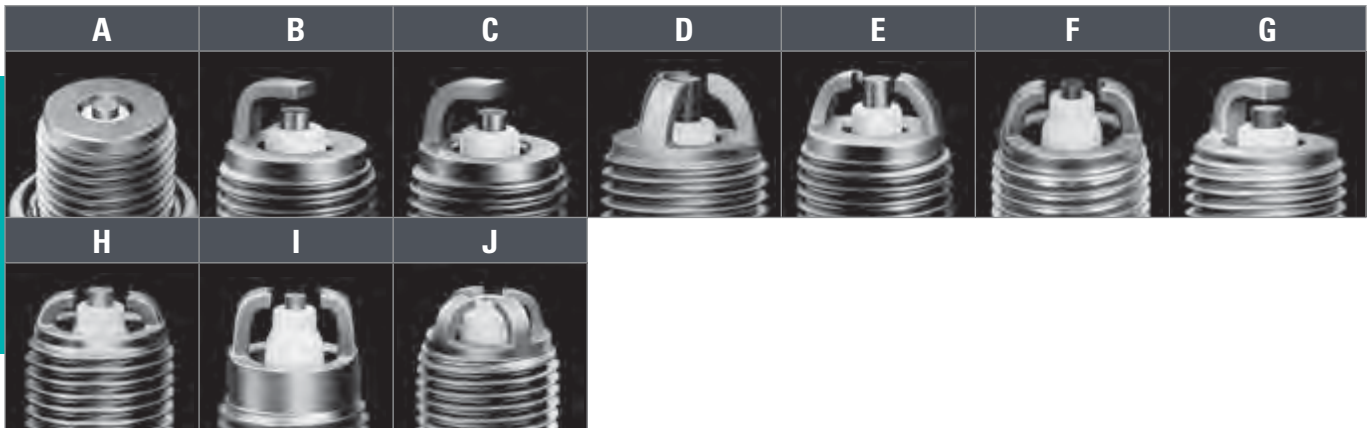
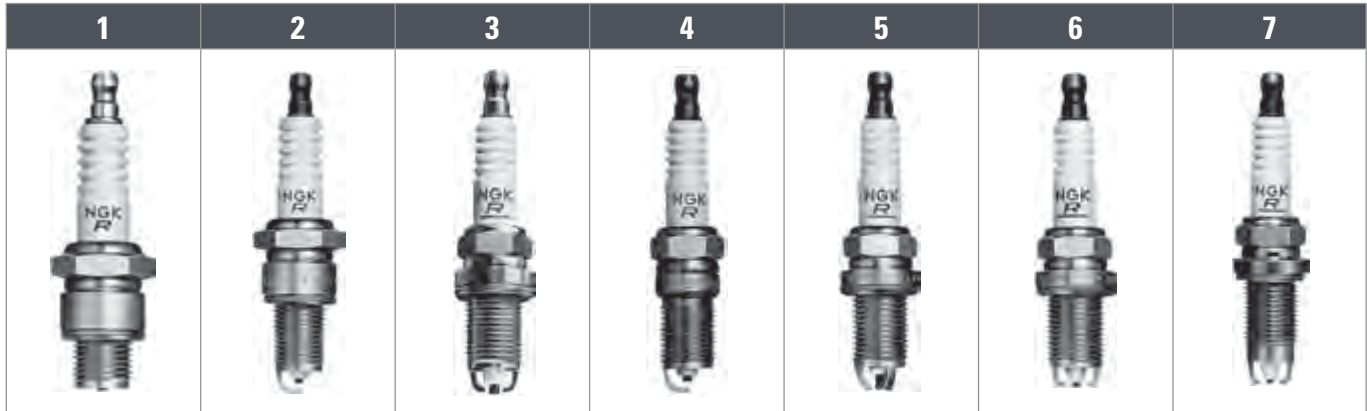

SEMI SURFACE DISCHARGE TYPES				
Fig	End	ISO	Non-Resistor	Resistor
14mmØ x 12.7mm 20.8 Hex				
1	A		BU8H	BUZ8H
14mmØ x 19.0mm 20.8 Hex				
2	B		BU6EA-11	BUR5EA-11 BUR6EA-11 BUR7EA-11
2	C			BUR4EB-11 BUR5EB-11 BUR6EB-11 BUR7EB-11
2	D			BUR5ET,-10 BUR6ET
3	E		BP5EK-A BP6EK-A	BPR5EK-A BPR6EK-A
3	F			BPR5EKU
14mmØ x 17.5mm 16.0 Hex - Conical seat				
4	G		BU6EFSZ	BUR6EFSZ
14mmØ x 19.0mm 16.0 Hex				
6	E	ISO		BKUR6EK,-9 BKUR7EK
5	D	ISO		BKUR5ET,-10 BKUR5ETZ-10 BKUR6ET,-10 BKUR6ETB BKUR7ET

SEMI SURFACE DISCHARGE TYPES				
Fig	End	ISO	Non-Resistor	Resistor
14mmØ x 19.0mm 16.0 Hex (cont)				
6	F	ISO	BK7EKU	BKR5EKU BKR6EKU BKR7EKU BKR6EKUE
6	H	ISO		BKR6EKUB
7	I			BKR5EKUC BKR6EKUC
6	J			BKR6EQUA

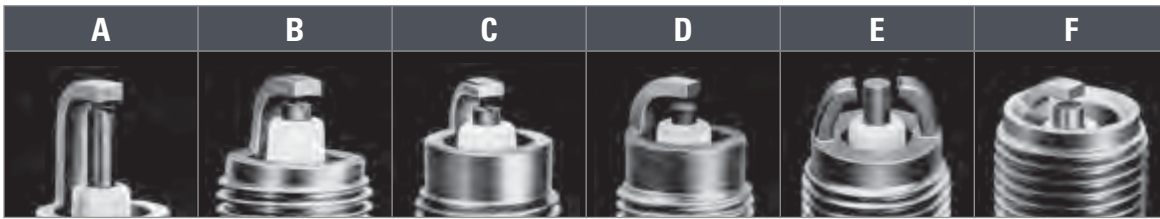
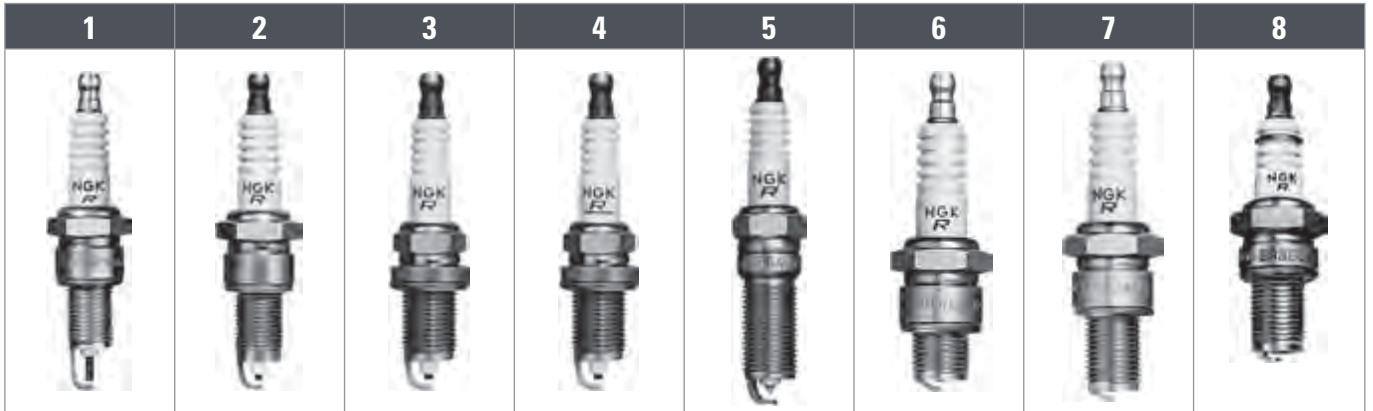

PROJECT GAP TYPES				
Fig	End	ISO	Non-Resistor	Resistor
14mmØ x 19.0mm 20.8 Hex				
1	A		BE527Y-11 BE529Y-11	BRE527Y-11 BRE529Y,-11
2	B			ZGR4A ZGR5A
14mmØ x 26.0mm 20.8 Hex				
2	D		ZG5D-11	
14mmØ x 20.5mm 20.8 Hex				
2	B			ZGR5B,-11 ZGR6B-11
14mmØ x 22.0mm 20.8 Hex				
2	C			ZGR5C
14mmØ x 19.0mm 16.0 Hex				
3	B		ZF6A-11	ZFR5A-11 ZFR6A-11
4	B	ISO		ZFR4F-11 ZFR5F,-11 ZFR6F-11,G ZFR7F,-11
		ISO		ZFR5J-11 ZFR6J-11 ZFR7J-11
3	A			BCRE527Y
14mmØ x 19.0mm 16.0 Hex				
3	B			ZFR6K-11S
	E			ZFR5G ZFR6G

PROJECT GAP TYPES				
Fig	End	ISO	Non-Resistor	Resistor
14mmØ x 22.5mm 16.0 Hex				
3	C			ZFR4E-11 ZFR5E-11 ZFR6E-11
3	D			ZFR5D-11 ZFR6D-11
14mmØ x 25.0mm 16.0 Hex - Conical seat				
5	B			LZTR4A-11 LZTR5A-13

COMPETITION TYPES				
Fig	End	ISO	Non-Resistor	Resistor
14mmØ x 12.7mm 20.8 Hex				
6	F		B7HCS B8HCS B9HCS	BR8HCS-10
14mmØ x 19.0mm 20.8 Hex				
7	F		B7ECS B8ECS B9ECS	BR8ECS BR9ECS BR10ECS
				BR8ECM BR9ECM BR10ECM
8	F			BR8ECM BR9ECM BR10ECM



SPARK PLUG RANGE

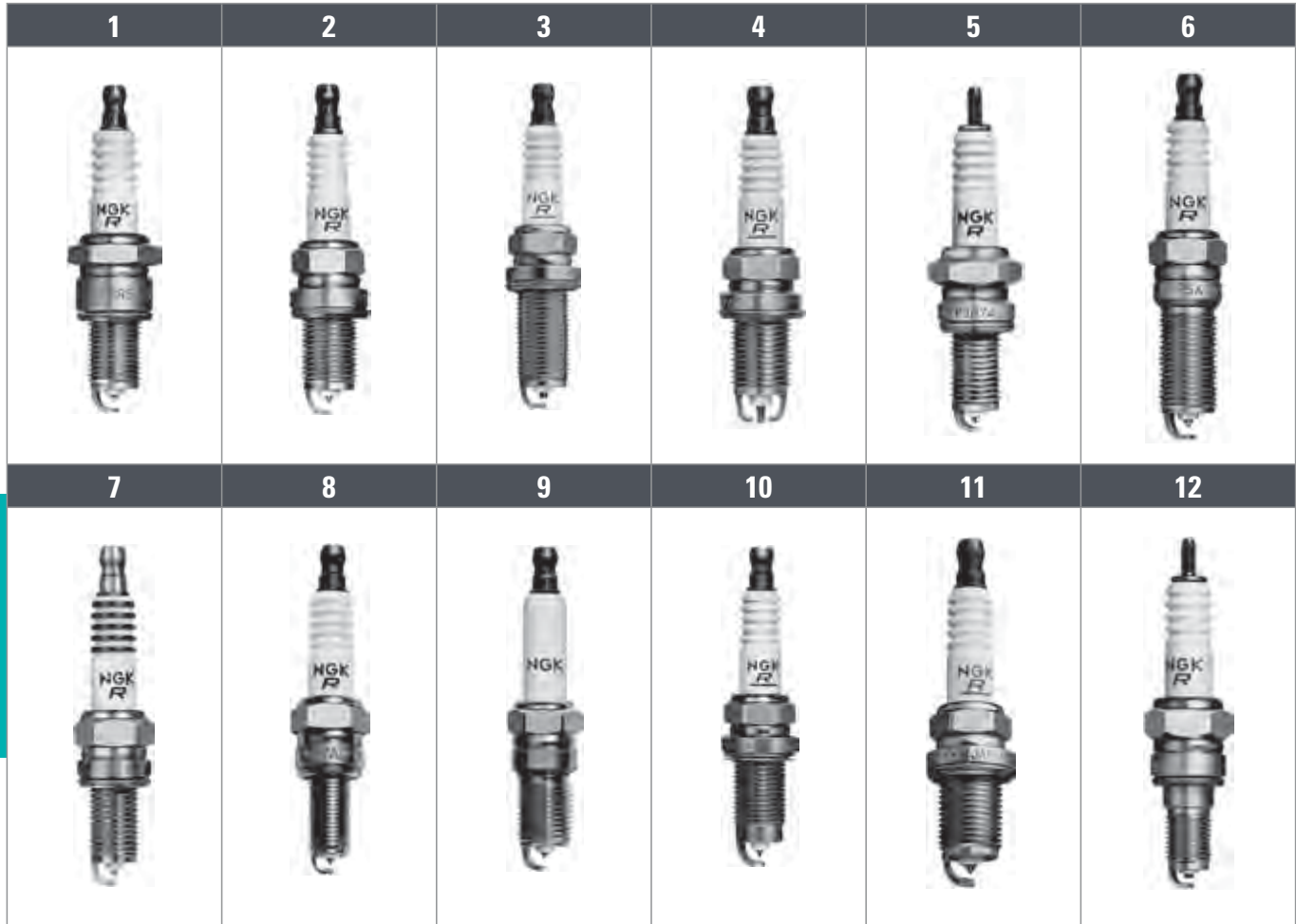

PLATINUM, IRIIDIUM TIPPED TYPES

Fig	End	ISO	Resistor
14mmØ x 19.0mm 16.0 Hex			
2	A		PFR5A-11 PFR5K-11 BCPR5EP-8,-11,-13 PFR6A-11 PFR6H-10 PFR6K-11 BCPR6EP-8,N-8,-11,-N-11,-13 PFR7A-11 PFR7H-10
		ISO	FR4AP-10,-11 FR4BP-11 FR5AP-10,-11 FR5BP-11 FR5AP-11E FR6AP-10,-11 FR6BP-11
		ISO	FR5EI-13
2	H		PFR4B-11 PFR4C-11 PFR5B,-9,-11,-11B PFR5C-11 PFR6B,-9,-11,-11B,-11C PFR6C-11 PFR6E-10 PFR7B,-9,-11,-11C PFR8B,-9
		ISO	PFR4G-11 PFR5J-11 PFR5G-11,-13E PFR6H-10 PFR6J,-11 PFR6G,-9,-11,-13,-13E PFR6H-10 PFR6J,-11 PFR7G,-9,-11
		ISO	PFR4P PFR5L-11 PFR5N-11 PFR5P,-11 PFR6Q PFR6L-11,-13 PFR6N-11 PFR6P,-11 PFR6Q PFR7N-D PFR7Q
	ISO	PFR5R-11	
	ISO	BKR5EP-8,-11 BKR6EP-8,-11,-13,-N-8	

PLATINUM, IRIIDIUM TIPPED TYPES

Fig	End	ISO	Resistor
14mmØ x 19.0mm 16.0 Hex (cont)			
4	C	ISO	BKR6EKPA
4	D	ISO	BKR5EKUP
4	E	ISO	BKR5EKP-11,-13 BKR6EKP-11
4	J	ISO	BKR5EQUA BKR6EQUA BKR6EQUA
3	F	ISO	PFR6M PFR7M
3	G	ISO	PZFR5B PZFR5F,-11,-13 PZFR6B PZFR6F,-11 PZFR7F
3	H	ISO	IFR5A11,-8N IFR5D10 IFR5E11 IFR6A11 IFR6C IFR6D10 IFR6E11 IFR7F-D
		ISO	IFR5G11 IFR5J11 IFR5N10 IFR6T11 IFR6J11 IFR6S IFR6T11
2	G		IZFR5B IZFR5F11 IZFR6B IZFR6F11
			ZFR5LP-13G



SPARK PLUG RANGE

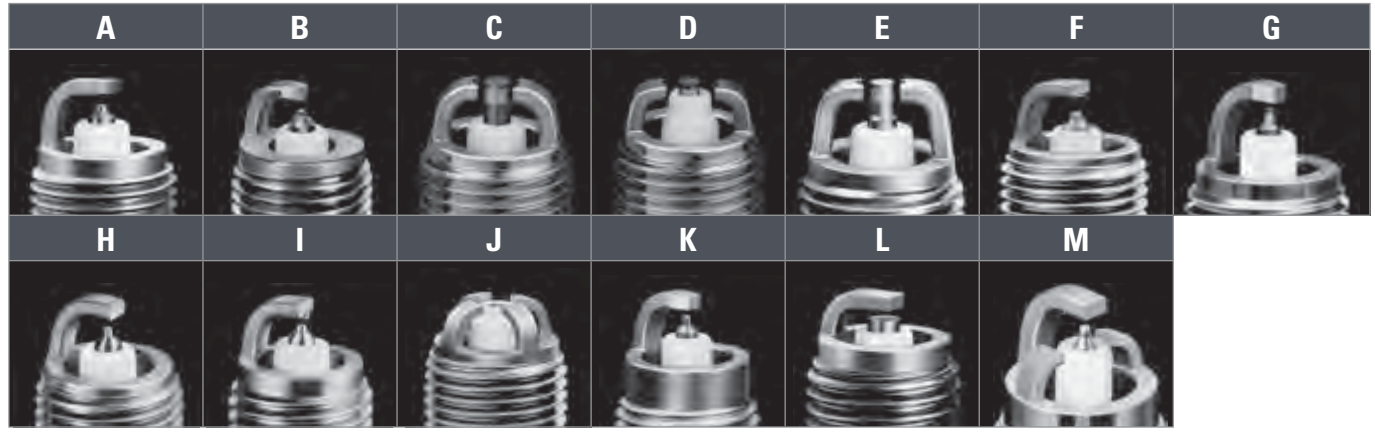

PLATINUM, IRIIDIUM TIPPED TYPES			
Fig	End	ISO	Resistor
14mmØ x 19.0mm 20.8 Hex			
1	I		PGR5A,-11 PGR5C-11 BPR5EP-11,-13 PGR6A,-11 PGR6C-11 BPR6EP-8 PGR7A,-11 IGR7A
1	H		IGR5C13
14mmØ x 22.0mm 16.0 Hex			
10	K	ISO	PZFR5C PZFR5D-11
		ISO	IZFR5C IZFR7E-D
14mmØ x 25.0mm 16.0 Hex - Conical seat			
6	H		PTR5A-13
14mmØ x 17.5mm 16.0 Hex - Conical seat			
9	I		PTR4B-15 PTR5C-13,-15 ITR4A15 ITR5F13 ITR6F13
3	H		PTR5D-10,-13 PTR6D-13,-13G
9	G		PZTR5A-15
14mmØ x 20.5mm 16.0 Hex			
3	A		IZFR6K11,11E,13 IZFR6K,-11S,11NS
14mmØ x 21.5mm 16.0 Hex			
	M		PZFR5N-11T
14mmØ x 22.0mm 16.0 Hex			
			PZFR6J-11
14mmØ x 26.5mm 16.0 Hex			
11	A		PLFR4A-11 PLFR5A-9,-11 PLFR6A-9,-11 PLFR7A-9
	G		ILZFR6A11
	J		LZFR5AQP

PLATINUM, IRIIDIUM TIPPED TYPES			
Fig	End	ISO	Resistor
14mmØ x 25.0mm 16.0 Hex - Conical seat			
			PLZTR4A-13,PLZTR5A-13
12mmØ x 19.0mm 18.0 Hex			
5	H		PJR6A PJR7A PJR8A IJR7A9
12mmØ x 19.0mm 16.0 Hex			
7	I		PKR7A PKR9B
7	C		DCPR8EKP
12mmØ x 22.0mm 16.0 Hex			
			IZKR7A
12mmØ x 28.0mm 16.0 Hex			
			ILZKR7B11 ILZKR7B-11S ILZKR7B11GS
10mmØ x 19.0mm 16.0 Hex			
8	I		PMR7A PMR8A PMR8B
12			IMR9C-9H IMR9C-9HE, IMR9C-9HES
12mmØ x 26.5mm 14.0mm Bi-Hex			
			ILZKBR7A-8G PLZKBR7A-G



SPARK PLUG RANGE

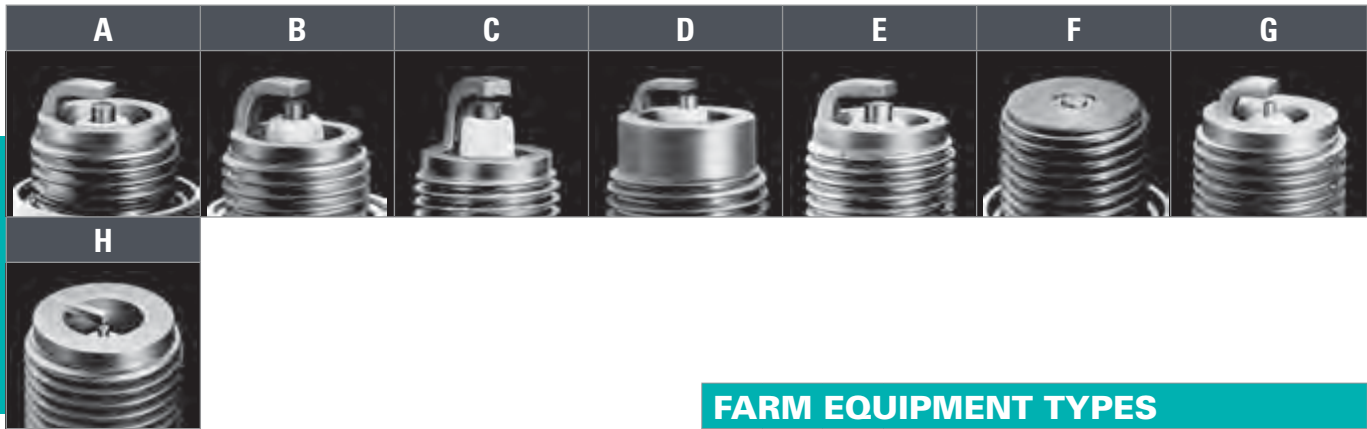

COMPACT TYPES

Fig	End	ISO	Non-Resistor	Resistor
14mmØ x 9.5mm 19.0 Hex				
1	A		BM4A BM6A BM7A	BMR2A,-10 BMR4A BMR6A BMR7A
1	B		BPM4A,-10 BPM6A,-10 BPM7A	BPMR4A,-10 BPMR6A,-10 BPMR7A,-9
14mmØ x 9.5mm 20.8 Hex				
1	A		B2-LM B4-LM BM6 BM7	BR2-LM BR4-LM
14mmØ x 12.7mm 20.8 Hex				
2	A		BL-6H	
14mmØ x 7.8mm 16.0 Hex - Conical seat				
3	A		BM6F BM6FY BM7F	BMR6F
3	B		BPM6F BPM7F	BPMR6F
10mmØ x 8.6mm 14.0 Hex				
4	A		CM-6	
10mmØ x 9.5mm 16.0 Hex				
8	A			CMR6A CMR7A
10mmØ x 12.7mm 16.0 Hex				
8	E			CMR5H CMR6H CMR7H
14mmØ x 9.5mm 19.0 Hex				
1	C		BPM6Y BPM7Y BPM8Y	BPMR6Y BPMR8Y

FARM EQUIPMENT TYPES

Fig	End	ISO	Resistor
PF1/2" x 22.5mm 23.8 Hex			
5	D		G-27 G-2Z

SURFACE DISCHARGE TYPES

Fig	End	ISO	Non-Resistor	Resistor
14mmØ x 12.7mm 20.8 Hex				
6	F		BUHX(Series gap) BUHXW-1(Series gap)	
			BUH	
			BUHW BUHW-2	BUZHW BUZHW-2
14mmØ x 19.0mm 20.8 Hex				
7	F		BUE	

RACING TYPES

Fig	End	ISO	Nickel Electrode	Precious Metal Electrode	Platinum Electrode
14mmØ x 19.0mm 20.8 Hex					
9	G		B8EG BR8EG*	B8EGV B85EGV	
			B9EG BR9EG*	B9EGV B95EGV	
			B10EG BR10EG*	B10EGV B105EGV	
			B11EG	B11EGV	
9	H				B8EGP B85EGP B9EGP B95EGP B10EGP

*Resistor Type



SPARK PLUG RANGE

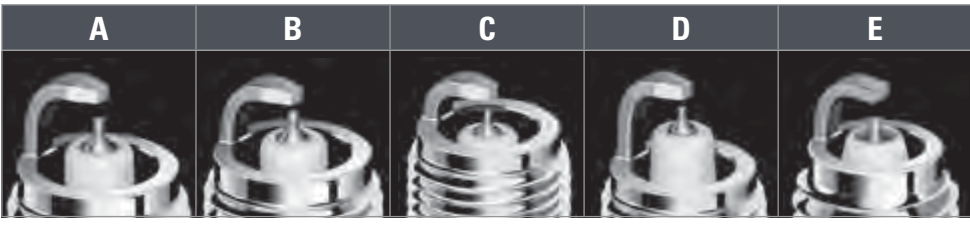

IX TYPES			
Fig	End	ISO	Resistor
12mmØ x 19.0mm 16.0 Hex			
1	A		DCPR6EIX DCPR7EIX DCPR8EIX DCPR9EIX
			D CR7EIX D CR8EIX D CR9EIX
		12mmØ x 19.0mm 18.0 Hex	
		2	A
B	DR7EIX DR8EIX DR9EIX		
	12mmØ x 21.0mm 18.0 Hex		
	3	A	DPR8ZIX
12mmØ x 26.5mm 14.0 Hex - Conical seat			
4	D		ZNAR6AIX-11 ZNAR7AIX

IX TYPES				
Fig	End	ISO	Resistor	
10mmØ x 19.0mm 16.0 Hex				
5	A		CPR7EAIX-9	
	5	C	CR7EIX CR8EIX CR9EIX CR10EIX	
6			B	CR8EHIX-9 CR9EHIX-9
			10mmØ x 12.7mm 16.0 Hex	
7			B	CR5HIX CR6HIX CR7HIX CR8HIX CR9HIX
	8mmØ x 19.0mm 13.0 Hex			
	8	E		ER8EHIX ER9EHIX



SPARK PLUG RANGE

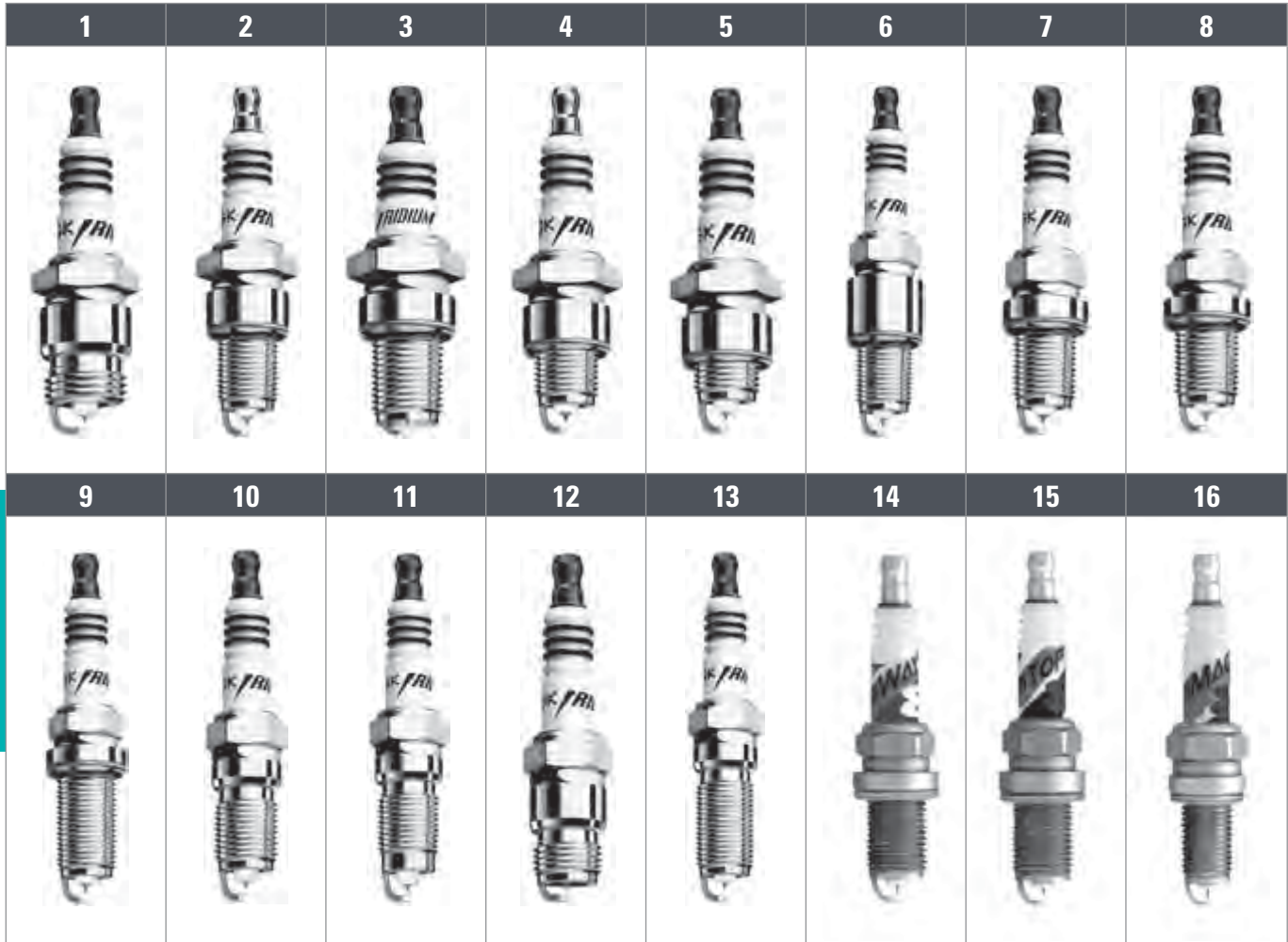

IX TYPES			
Fig	End	ISO	Resistor
18mmØ x 10.9mm 20.8 Hex			
1	A		WR5IX
14mmØ x 19.0mm 20.8 Hex			
2	B		GR4IX GR5IX
			BPR5EIX,-11 BPR6EIX,-11 BPR7EIX BPR8EIX BPR9EIX
			BR7EIX BR8EIX BR9EIX BR10EIX
			BR8ECSIX BR9ECSIX,-5
			BR8ECMIX BR9ECMIX BR10ECMIX

IX TYPES			
Fig	End	ISO	Resistor
14mmØ x 12.7mm 20.8 Hex			
4	B		BPR6HIX BPR7HIX BPR8HIX
			BR6HIX BR7HIX BR8HIX BR9HIX BR10HIX
14mmØ x 9.5mm 20.8 Hex			
5	A		XR4IX XR45IX XR5IX

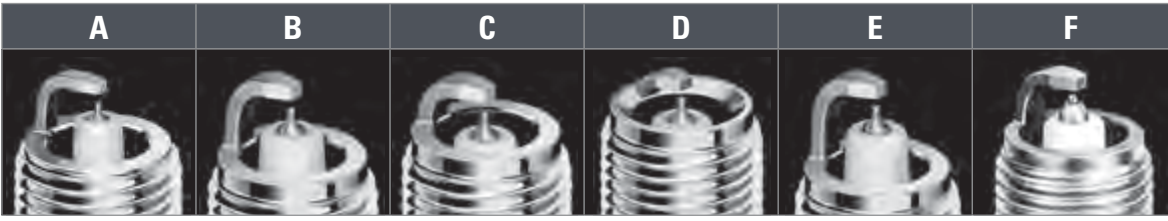

IX TYPES

Fig	End	ISO	Resistor
14mmØ x 19.0mm 16.0 Hex			
6	B		BCPR7EDIX
7	B		BCPR5EIX,-11
			BCPR6EIX,-11
			BCPR7EIX,-11
8	B		BKR4EIX
			BKR5EIX,-11
			BKR6EIX,-11
			BKR7EIX,-11
			BKR8EIX
			BKR9EIX
8	E		ZFR5FIX-11
			ZFR6FIX-11
14mmØ x 26.5mm 16.0 Hex			
9	B		LFR5AIX-11
			LFR6AIX-11
			LFR7AIX
14mmØ x 17.5mm 16.0 Hex - Conical seat			
10	B		BPR6EFIX-10,-15
10	A		TR4IX
			TR5IX TR55IX
			TR6IX TR65IX
			TR7IX TR75IX
			TR8IX TR85IX
11	E		TR45-11X
			TR5-11X TR55-11X

IX TYPES

Fig	End	ISO	Resistor
14mmØ x 11.2mm 16.0 Hex - Conical seat			
12	C		YR5IX YR55IX
			BR6FIX
12	A		UR4IX UR45IX
			UR5IX UR55IX
			UR6IX
14mmØ x 25.0mm 16.0 Hex - Conical seat			
13	B		LTR5IX-11
			LTR6IX-11
			LTR7IX-11
13	E		LZTR4AIX-11
			LZTR5AIX-13
			LZTR6AIX-13
			LZTR7AIX-13

COLDER IRIIDIUM TYPES

Fig	End	ISO	Non-Resistor	Resistor
14mmØ x 19.0mm 16.0 Hex				
14	F	ISO	BKR-E	IRIWAY7
				IRIWAY8
				IRIWAY9
15	F		BCPR-E	IRITOP7
				IRITOP8
				IRITOP9
12mmØ x 19.0mm 16.0 Hex				
16	F		DCPR-E	IRIMAC8 IRIMAC9



SPARK PLUG RANGE

INTERCHANGEABILITY OF NGK IRIIDIUM IX – VEHICLE

Iridium Part	STANDARD		V-GROOVE		PLATINUM		Racing
	Non-Resistor	Resistor	Non-Resistor	Resistor	Non-Resistor	Resistor	
BPR5EIX	BP5ES BP5EA-L BP5ET	BPR5ES BUR5ET	BP5EY	BPR5EY BPR5E	BP5EVX	BP5EVX	
BPR6EIX	BP6ES BP6EA BP6ET	BPR6ES BPR6EKN BUR6ET	BP6EY BP6E	BP6EY BP6E	BP6EVX	BP6EVX	
BPR7EIX	BP7ES BP7EKN BP7ET	BPR7ES BPR7EKN BPR7ES-11 BUR7EA-11	BP7EY BP7E	BPR7EY BPR7E BPR7EY-11	BP7EVX	BPR7EVX	
BPR8EIX	BP8ES	BPR8ES			BP8EVX	BPR8EVX	
BPR9EIX	BP9ES	BPR9ES			BP9EVX	BPR9EVX	
BPR5EIX-11	BP5EA-L-11 BP5ES-11 BP5ES-13 BP5EK-A BP5EKN BP5ET-10	BPR5ES-11 BPR5ES-13 BPR5EK-A BUR5EA-11 BUR5ET-10	BP5EY-11	BPR5EY-11 BPR5E-11 BRE527Y-11	BP5EVX-11	BPR5EVX-11	
BPR6EIX-11	BP6EA-11 BP6ES-11 BP6ES-13 BP6EKN BP6EK-A	BPR6ES-11 BPR6EK-A BPR6EA-11	BP6EY-11	BPR6EY-11 ZGR6B-11	BP6EVX-11	BPR6EVX-11	
BR10EIX	B10ES B10ECS	BR10ES			B10EVX		B10EG BR10EG B10EGV
BCPR5EIX-11	BCP5ES-11 BCP5ES	BCPR5ES-11 BCPR5ES	BCP5EY-11 BCP5E-11 BCP5E	BCPR5EY-11 BCPR5EY-N-11 BCPR5E-11 BCPR5EY BCPR5E	BCP5EVX-11 BCP5EVX	BCPR5EVX-11	
BCPR6EIX-11	BCP6ES-11 BCP6ES	BCPR6ES-11 BCPR6ES	BCP6E-11 BCP6E	BCPR6EY-11 BCPR6EY-N-11 BCPR6E-11 BCPR6EY BCPR6E	BCP6EVX-11 BCP6EVX	BCPR6EVX-11	
BCPR7EDIX		BCPR7EKD					
BKR5EIX	BCP5ET	BKR5ES BKR5EK BCPR5ET	BK5E	BKR5EY BKR5EYA BKR5E		BKR5EVX	
BKR6EIX	BCP6ET	BKR6ES BKR6EK BKR6EKC BKUR6EK-9 BCPR6ET	BK6E	BKR6EY BKR6EYA BKR6E		BKR6EVX	
BKR5EIX-11		BKR5ES-11 BKR5EKB-11	BK5E-11	BKR5EY-11 BKR5EYA-11 BKR5E-11 BKR5E-N-11		BKR5EVX-11	
BKR6EIX-11		BKR6ES-11 BKUR6EK BKR6EKB-11 BKR6EKC-N-11	BK6E-11	BKR6EY-11 BKR6EYA-11 BKR6E-11 BKR6E-N-11		BKR6EVX-11	
BKR7EIX-11		BKR7ES-11		BKR7E-11			
DCPR7EIX	DCP7E	DCPR7E			DCP7EVX	DCPR7EVX	
ZFR5FIX-11				ZFR5F-11 ZFR5J-11 ZFR5F		ZFR5FVX-11	
ZFR6FIX-11				ZFR6F-11 ZFR6J-11		ZFR6FVX-11	
UR5IX	BP5FS	BPR5FS BPR5FS-11	BP5F				
UR55IX		BPR5FS-15					
UR6IX		BPR6FS	BP6F				
TR5IX	BP5EFS	BPR5EFS				BPR5EFVX TR5VX	
TR55IX	BP5EFS-13	BPR5EFS-13 BPR5EFS-13		BPR5EF-13		TR55VX	
BPR6EFIX-10	BP6EFS	BPR6EFS	BP6EF	BPR6EF			
BPR6EFIX-15	BP6EFS-13	BPR6EFS-13 BPR6EFS-15	BP6EF-13 BP6EF-15	BPR6EF-13 BPR6EF-15			
TR75IX		BPR7EFS-15					
XR4IX	BP4S						
XR5IX	BP5S						
LFR5AIX-11				LFR5A-11			
LFR6AIX-11				LFR6A-11			

Iridium Part	STANDARD		V-GROOVE		PLATINUM		Racing
	Non-Resistor	Resistor	Non-Resistor	Resistor	Non-Resistor	Resistor	
CR5HIX	C5HA C5HSA	CR5HSA					
CR6HIX	C6HA C6HSA	CR6HSA CR6HS					
CR7HIX	C7HA C7HSA	CR7HSA			C7HVX		
CR8HIX	C8HA C8HSA	CR8HSA CR8HS LR8A			C8HVX	CR8HVX	
CR7EIX	C7E	CR7E CR7EK					
CR8EHIX-9	C8EH-9	CR8EH-9			C8EHVX-9	CR8EHVX-9	
CR9EHIX-9	C9EH-9	CR9EH-9			C9EHVX-9	CR9EHVX-9	
CR8EIX	C8E	CR8E CR8EK			C8EVX	CR8EVX	
CR9EIX	C9E	CR9E CR9EK			C9EVX	CR9EVX	
DR8EIX	D8EA	DR8EA DR8ES,-L JR8B JR8C			D8EVX	DR8EVX	
DR9EIX	D9EA J9A	DR9EA JR9B JR9C			D9EVX	DR9EVX	
DCR7EIX	For Harley Davidson						
DCR8EIX	For Ducati						
DCR9EIX							
DPR7EIX-9	DP7EA-9	DPR7EA-9				DPR7EVX-9	
DPR8EIX-9	DP8EA-9	DPR8EA-9			DP8EVX-9	DPR8EVX-9	
DPR9EIX-9	DP9EA-9	DPR9EA-9			DP9EVX-9	DPR9EVX-9	
BPR6EIX	BP6ES	BPR6ES			BP6EVX	BPR6EVX	
BPR7EIX	BP7ES	BPR7ES			BP7EVX	BPR7EVX	
BPR6HIX	BP6HS BP6HS-10 BP6HSA	BPR6HS BPR6HS-10 BPR6HSA BR6HSA			BP6HVX	BPR6HVX	
BPR7HIX	BP7HS BP7HS-10	BPR7HS BPR7HS-10			BP7HVX	BPR7HVX	
BPR8HIX	BP8HS BP8HS-10 BP8HSA	BPR8HS BPR8HS-10 BPR8HSA BR8HSA			BP8HVX		
BR6HIX	B6HS B6HS-10	BR6HS BR6HS-10			B6HVX		
BR7HIX	B7HS B7HS-10	BR7HS BR7HS-10			B7HVX		
BR8HIX	B8HS B8HS-10	BR8HS BR8HS-10 BR8HCS-10			B8HVX	BR8HVX	
BR7EIX	B7ES B7ECS	BR7ES BR7ECS			B7EVX	BR7EVX	B7EG BR7EG B7EGV
BR8EIX	B8ES B8ECS	BR8ES BR8ECS			B8EVX	BR8EVX	B8EG BR8EG B8EGV
BR9EIX	B9ES B9ECS	BR9ES BR9ECS		BR9EYA	B9EVX	BR9EVX	B9EG BR9EG B9EGV
BR10EIX	B10ES B10ECS	BR10ES BR10ECS		BR10EYA	B10EVX	BR10EVX	B10EG BR10EG B10EGV



NOTES

PLATINUM

DURABILITY

FUTURE

TECH

IRIDIUM

PLATINUM

**SPARK PLUG RESISTOR
CAP RANGE**

FUTURE

PRECIOUS METAL

AUTOMATION

VALU



SPARK PLUG RESISTOR CAP RANGE

L B 05 E P K -R

External appearance	
L	90° ø Elbow type
S	Straight
X	102° ø Elbow type
V	102° ø Elbow type (long)
Y	102° ø Elbow type (short)
T	T type

Resistance	
None	No resistor
01	1K Ω
05	5K Ω
10	10K Ω



Adaptable plug thread size	
B	14mm ø thread
C	10mm ø thread CM-6 only
D	10 & 12mm ø thread
Z	10, 12 & 14mm ø thread

Adaptable plug terminal	
E	For terminal nut or solid post terminal
F	For terminal stud or threaded terminal

Accessory	
A	Special design
H	Compact type
P	With special waterproof cover
K	With silicon waterproof cover
M	Rubber sheathed
G	With rubber grommet
W	Double connector springs
F	For 5mm ø cable
L	Inductive resistor type
Y	With handle
Z	Special shape
C	Cable

Plug cap colour	
-B	Blue
-G	Green
-R	Red
-Y	Yellow
None	Black

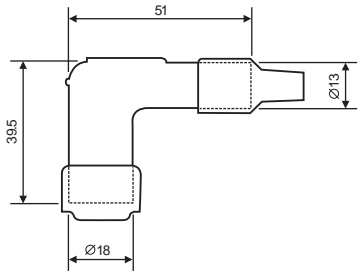

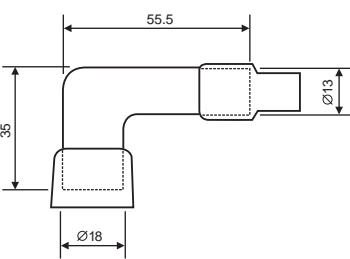





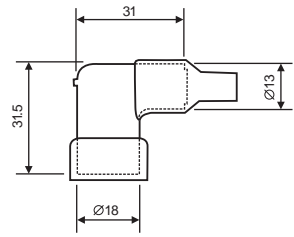

Please Note: Not all configurations are carried in Australia and New Zealand. Please check with your distributor.

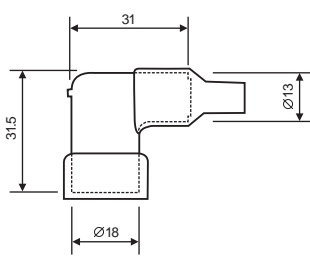
Configuration (applicable plug thread dia. body material)	Unit: mm	Part Number	— (k Ω)
 <p>LB Type: 14mm ø thread LZ Type: 10, 12 & 14mm ø thread Phenolic Resin</p> <p><Excluding LB○EZ></p>	 <p>Dimensions: 51, 39.5, 13, 18</p>	LB-E	No Resistor
		LB○E	05
		LB○EP	05
		LB○EZ	05
 <p>10, 12 & 14mm ø thread Phenolic Resin</p> <p><LB○EZ></p>	 <p>Dimensions: 55.5, 35, 13, 18</p>	LBF	No Resistor
		LB○F	01, 05, 10
		LB○FP	05
		LZ○F	01, 05

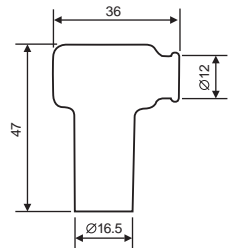

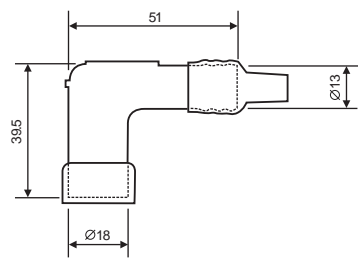
SPARK PLUG RESISTOR CAP RANGE

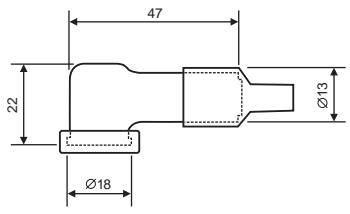

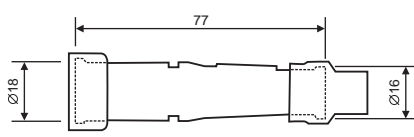





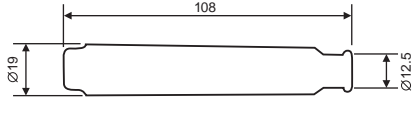

Note: Not all configurations are carried in Australia & New Zealand. Please check with your distributor.

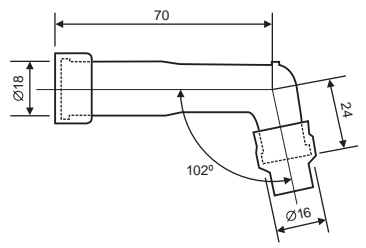
Configuration (applicable plug thread dia. body material)	Unit: mm	Part Number	—— (kΩ)
 <p>10, 12 & 14mm Ø thread Phenolic Resin</p>		LZEH	
		LZFH	No Resistor
 <p>LB Type: 14mm Ø thread LZ Type: 10, 12 & 14mm Ø thread Phenolic Resin</p>		LB [○] EH	01, 05, 10
		LB [○] EHF	05
 <p>14mm Ø thread Rubber Sheathed</p>		LB [○] EMH	05
 <p>10 & 12mm Ø thread Phenolic Resin</p>		LD-F	No Resistor
		LD [○] F	05, 10
		LD [○] FP	05
 <p>10mm Ø CM6 only Phenolic Resin</p>		LC [○] EFK	05
 <p>SB Type: 14mm Ø thread SD Type: 10 & 12mm Ø thread SZ Type: 10, 12 & 14mm Ø thread Phenolic Resin</p>		SB [○] E	05
		SB [○] F	05, 10
		SD [○] F	01, 05, 10
		SD [○] FP	05
		SZ [○] F	05

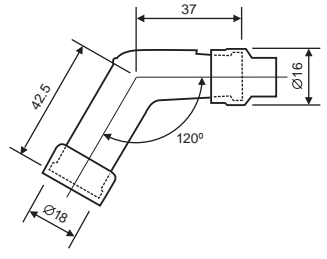

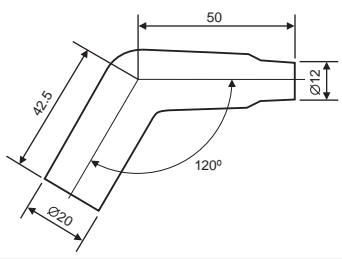

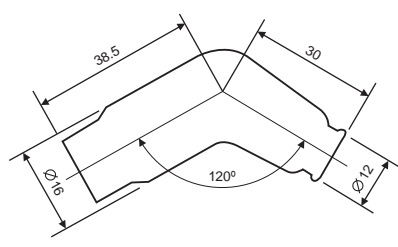

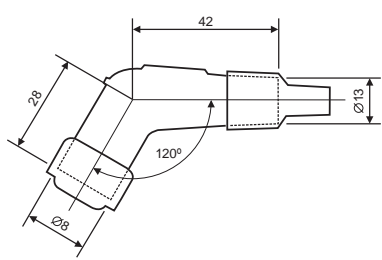



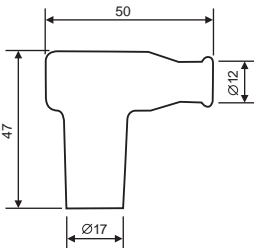

SPARK PLUG RESISTOR CAP RANGE

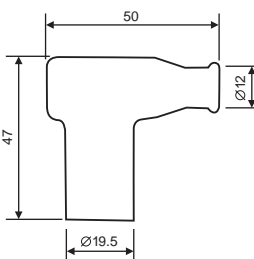
Note: Not all configurations are carried in Australia & New Zealand. Please check with your distributor.

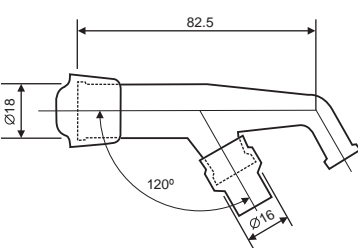
Configuration (applicable plug thread dia. body material)	Unit: mm	Part Number	— (kΩ)
 <p>10 & 12mm Ø thread Rubber Sheathed</p>		SD◊FM SD◊FMC	05 05
 <p>XB Type: 14mm Ø thread XD Type: 10 & 12mm Ø thread XZ Type: 10, 12 & 14mm Ø thread Phenolic Resin</p>		XB◊F XD◊F XZ◊F	05, 10 05, 10 05
 <p>VB Type: 14mm Ø thread VD Type: 10 & 12mm Ø thread Phenolic Resin</p>		VB◊E VB◊F VD◊F	05 05 05, 10
 <p>10 & 12mm Ø thread Rubber Sheathed (Silicone)</p>		VD◊FML	05
 <p>10 & 12mm Ø thread Rubber sheathed</p>		VD◊FMH	05
 <p>YB Type: 14mm Ø thread YD Type: 10 & 12mm Ø thread Phenolic Resin</p>		YB◊F YD◊F	05 05

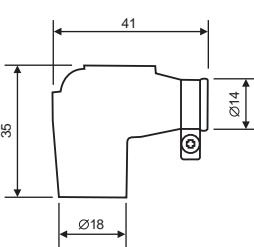
SPARK PLUG RESISTOR CAP RANGE

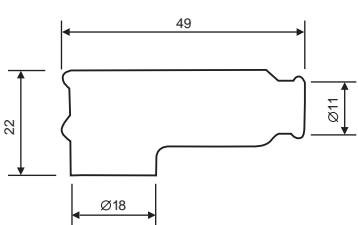
Note: Not all configurations are carried in Australia & New Zealand. Please check with your distributor.

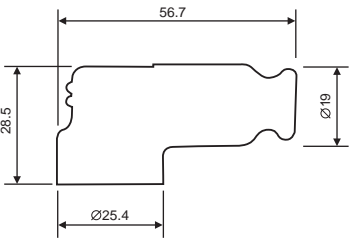
Configuration (applicable plug thread dia. body material)	Unit: mm	Part Number	—— (kΩ)
 <p>14 mm Ø thread Rubber Sheathed (Silicone)</p>		TB \odot EM-B	05, 10
 <p>14 mm Ø thread Rubber Sheathed</p>		TB \odot EMA	05
 <p>14 mm Ø thread Polyester Resin</p>		VB \odot EYK	05
 <p>14 mm Ø thread Rubber Sheathed (Silicone)</p>		LBER-R	No Resistor
 <p>14 mm Ø thread Rubber Sheathed (Silicone) For racing spark plug R6120-\odot only</p>		TRS1225-B	05
 <p>14 mm Ø thread Rubber Sheathed (Silicone) For racing spark plug R6120-\odot, R5300N-\odot only</p>		TRS1408F-B	05







SPARK PLUG RESISTOR CAP RANGE

Note: Not all configurations are carried in Australia & New Zealand. Please check with your distributor.

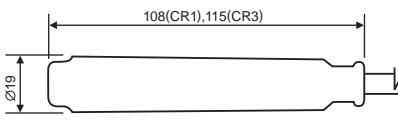

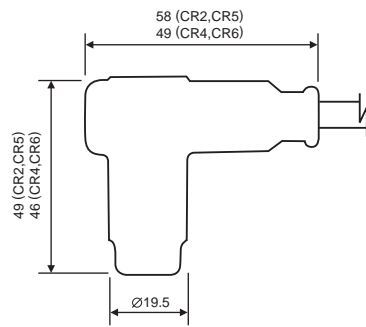
Cable	Colour Red	Cover configuration	Adaptable plug terminal	Cable length
1		Straight cover	For terminal stud	500mm
2		90° cover	For terminal stud	500mm
3		90° cover	For integrated terminal	500mm

Configuration (applicable plug thread dia. body material)	Unit: mm	Part Number	(kΩ)
 <p>10, 12 & 14 mm Ø thread Rubber Sheathed (Silicone)</p>		CR1	05
 <p>10, 12 & 14 mm Ø thread Rubber Sheathed (Silicone)</p>		CR2 CR4	05 05
 <p>Cable Splicer</p>		J-1	-

IRIDIUM

PLATINUM

MARINE OUTBOARD RANGE

FUTURE

PRECIOUS METAL

AUTOMATION

VALU

VALUE

TECH

GADGET

MACHINE

MOVE

CERAMIC

GENUINE

TEC

CERAMICS

ADVANCE

FUTURE

GADGET

TECH

FUTURE

INDUSTRY

INNOVATION

NEWEST

VALUE

RESEARCH

AUTOMATION

SCIENCE

FUTURE

INNOVATION

TECH

DIGITAL

KNOW-HOW

ELECTRON

CORE

OEM

OEM

VALUE

RESEARCH

IDEAS

GADGET

TECH

DIGITAL

OEM

RESEARCH

IDEAS

MOVE

TECH

DIGITAL

OEM

RESEARCH

IDEAS

MOVE

TECH

DIGITAL

OEM

RESEARCH

IDEAS

MOVE

TECH

DIGITAL

OEM

RESEARCH

IDEAS

MOVE

TECH

DIGITAL

OEM

RESEARCH

IDEAS

MOVE

TECH

DIGITAL

OEM

RESEARCH

IDEAS

MOVE

TECH

DIGITAL

OEM

RESEARCH

IDEAS

MOVE

TECH

DIGITAL

OEM

RESEARCH

IDEAS

MOVE

TECH

DIGITAL

OEM

RESEARCH

IDEAS

MOVE

TECH

DIGITAL

OEM

RESEARCH

IDEAS

MOVE

TECH

DIGITAL

OEM

RESEARCH

IDEAS

MOVE

TECH

DIGITAL

OEM

RESEARCH

IDEAS

MOVE

TECH

DIGITAL

OEM

RESEARCH

IDEAS

MOVE

TECH

DIGITAL

OEM

RESEARCH

IDEAS

MOVE

TECH

DIGITAL

OEM

RESEARCH

IDEAS

MOVE

TECH

DIGITAL

OEM

RESEARCH

IDEAS

MOVE

TECH

DIGITAL

OEM

RESEARCH

IDEAS

MOVE

TECH

DIGITAL

OEM

RESEARCH

IDEAS

MOVE

TECH

DIGITAL

OEM

RESEARCH

IDEAS

MOVE

TECH

DIGITAL

OEM

RESEARCH

IDEAS

MOVE

TECH

DIGITAL

OEM

RESEARCH

IDEAS

MOVE

TECH

DIGITAL

OEM

RESEARCH

IDEAS

MOVE

TECH

DIGITAL

OEM

RESEARCH

IDEAS

MOVE

TECH

DIGITAL

OEM

RESEARCH

IDEAS

MOVE

TECH

DIGITAL

OEM

RESEARCH

IDEAS

MOVE

TECH

DIGITAL

OEM

RESEARCH

IDEAS

MOVE

TECH

DIGITAL

OEM

RESEARCH

IDEAS

MOVE

TECH

DIGITAL

OEM

RESEARCH

IDEAS

MOVE

TECH

DIGITAL

OEM

RESEARCH

IDEAS

MOVE

TECH

DIGITAL

OEM

RESEARCH

IDEAS

MOVE

TECH

DIGITAL

OEM

RESEARCH

IDEAS

MOVE

TECH

DIGITAL

OEM

RESEARCH

IDEAS

MOVE

TECH

DIGITAL

OEM

RESEARCH

IDEAS

MOVE

TECH

DIGITAL

OEM

RESEARCH

IDEAS

MOVE

TECH

DIGITAL

OEM

RESEARCH

IDEAS

MOVE

TECH

DIGITAL

OEM

RESEARCH

IDEAS

MOVE

TECH

DIGITAL

OEM

RESEARCH

IDEAS

MOVE

TECH

DIGITAL

OEM

RESEARCH

IDEAS

MOVE

TECH

DIGITAL

OEM

RESEARCH

IDEAS

MOVE

TECH

DIGITAL

OEM

RESEARCH

IDEAS

MOVE

TECH

DIGITAL

OEM

RESEARCH

IDEAS

MOVE

TECH

DIGITAL

OEM

RESEARCH

IDEAS

MOVE

TECH

DIGITAL

OEM

RESEARCH

IDEAS

MOVE

TECH

DIGITAL

OEM

RESEARCH

IDEAS

MOVE

TECH

DIGITAL

OEM

RESEARCH

IDEAS

MOVE

TECH

DIGITAL

OEM

RESEARCH

IDEAS

MOVE

TECH

DIGITAL

OEM

RESEARCH

IDEAS

MOVE

TECH

DIGITAL

OEM

RESEARCH

IDEAS

MOVE

TECH

DIGITAL

OEM

RESEARCH

IDEAS

MOVE

TECH

DIGITAL

OEM

RESEARCH

IDEAS

MOVE

TECH

DIGITAL

OEM

RESEARCH

IDEAS

MOVE

TECH



MARINE – OUTBOARD RANGE

Make & Model	Other	Year	Recommended Part No.	Gap (mm)	Iridium Option
BRITISH ANZANI					
65			B6S	0.7	
180, 18HP			B-6L	0.7	
Magnitwin Fleetwin			B6HS	0.6	BR6HIX
Minor Seamaid, Jet 3			B5HS	0.6	
Pilot 1, 2, 3, 4, 30			B5HS	0.6	
Seasprite, Supertwin			B6HS	0.6	BR6HIX
Super Single, Super Snipe			AB-6	0.6	
Triton			B6ES	0.6	
Unitwin, 400			B6HS	0.6	BR6HIX
BRITISH SEAGULL					
2, 3, 4, 5, 6HP			AB-6	0.5	
Century, Century Plus (Magneto Ign)			AB-6	0.5	
Century, Century Plus (CDI Ign)			AB-6	0.5	
Featherweight (Magneto Ign)			AB-6	0.5	
Forty Minus, Forty Plus (Magneto Ign)			AB-6	0.5	
Featherweight, Forty Plus (CDI Ign)			AB-6	0.5	
Minor BM			B6HS	0.5	BR6HIX
Silver Century, Silver Century Plus			AB-6	0.5	
45, 55, 60, 75, 80, 90			AB-6	0.5	
125, 160, SD160, 170			B7ES	0.8	BR7EIX
QB Series, Curlew, Osprey, Kingfisher			B7ES	0.8	BR7EIX
CHRYSLER (SEE ALSO FORCE)					
3.5HP		1965-69	B-6L	0.8	
		1980-84	B6HS	0.8	BR6HIX
4.0HP		1976-84	B6HS	0.8	BR6HIX
4.4HP		1968	B6HS	0.8	BR6HIX
4.5HP		1972	B6HS	0.8	BR6HIX
4.9HP		1973-75	B5HS	0.8	
5HP		1969-70	B6HS	0.8	BR6HIX
		1974-76	B5HS	0.8	
6HP		1965-67	B-6L	0.8	
		1971-77	B6HS	0.8	BR6HIX
		1978-82	B6HS	0.8	BR6HIX
	Sailor 150	1980	B6HS	0.8	BR6HIX
6.6HP		1968	B6HS	0.8	BR6HIX
7HP		1969-70	B6HS	0.8	BR6HIX
7.5HP		1979-84	B6HS	0.8	BR6HIX
	Sailor 190	1979	B6HS	0.8	BR6HIX
	Sailor 180	1981-84	B6HS	0.8	BR6HIX
8HP		1971-81	B6HS	0.8	BR6HIX
9.0HP		1965	BR6S	0.8	
9.2HP		1966-67	BR6S	0.8	
9.9HP		1968-86	B6HS	0.8	BR6HIX
	Sailor 250	1979-84	B6HS	0.8	BR6HIX

Make & Model	Other	Year	Recommended Part No.	Gap (mm)	Iridium Option
10HP		1974-78	B6HS	0.8	BR6HIX
12HP		1979	B6HS	0.8	BR6HIX
	Sailor 300	1979	B6HS	0.8	BR6HIX
12.9HP		1971-73	B6HS	0.8	BR6HIX
15HP		1974-84	B6HS	0.8	BR6HIX
20HP		1968-82	B6HS	0.8	BR6HIX
25HP		1973-78	B6HS	0.8	BR6HIX
		1981-84	B6HS	0.8	BR6HIX
30HP		1973-75	B6HS	0.8	BR6HIX
		1979-82	B6HS	0.8	BR6HIX
35HP		1968-84	B6HS	0.8	BR6HIX
45HP		1968-77	B6HS	0.8	BR6HIX
	Magna Power Ign	1971-78	BUHX	0.75	
	Std Ign	1971-78	B7HS	0.7	BR7HIX
		1982-84	B7HS	0.7	BR7HIX
50HP		1981-84	B7HS	0.7	BR7HIX
55HP	Std Ign	1967-76	B6HS	0.8	BR6HIX
	Magna Power Ign	1969-80	BUHX	0.75	
		1981-83	BUHW	1.3	
60HP		1974-76	BUHX	0.75	
		1984	BUHW	1.3	
65HP		1977-78	BUHX	0.75	
70HP		1969-73	BUHW	1.3	
		1979-80	BUHW	1.3	
75HP		1966-67	BR6S	0.8	
		1968	BUHX	0.75	
		1974-84	BUHW	1.3	
80HP		1965	BR6S	0.8	
85HP		1969-73	BUHW	1.3	
		1978-83	BUHW	1.3	
		1984-86	BUHX	0.75	
90HP	3cyl.	1974-77	BUHW	1.3	
		1983-84	BUHX	0.75	
100HP		1980-84	BUHW	1.3	
105HP		1966-67	BR6S	0.8	
		1968-74	BUHW	1.3	
		1975-76	BUHX	0.75	
		1977-78	BUHW	1.3	
		1982-83	BUHW	1.3	
115HP		1977-82	BUHW	1.3	
		1983-84	BUHX	0.75	
120HP		1970-77	BUHW	1.3	
125HP		1981	BUHX	0.75	
130HP		1972-73	BUHW	1.3	
135HP		1969-71	BUHW	1.3	
		1974-77	BUHW	1.3	
140HP		1978-84	BUHW	1.3	
150HP		1972-76	BUHW	1.3	

Make & Model	Other	Year	Recommended Part No.	Gap (mm)	Iridium Option
EVINRUDE					
Note: "Z" type inductive suppressor plugs are recommended for all VRO and 60° Looper V engines					
1.5HP		1968-70	B6S	0.8	
2.0HP	Jr. Colt	1971-90	BR6S	0.8	
		1991 on	BPR6HS	0.8	BPR6HIX
2.3HP		1991 on	BPR6HS	0.8	BPR6HIX
2.5HP		1987-88	BZ7HS-10	0.8	
3.0HP		1952-68	B6S	0.8	
		1989-97	BR6HS	0.8	
3.3HP		1991-03	BPR6HS	0.8	BPR6HIX
3.5HP		2001 on	BPR6HS	0.8	BPR6HIX
4.0HP		1969-76	B6S	0.8	
		1977-87	BR6HS	0.8	
	Ultra, Excel	1987-88	B7HS-10	0.8	
		1989-01	BR6HS	0.8	
	4 Stroke	2003 on	BPR6ES	0.8	BPR6EIX
4.5HP		1980-85	BR6HS	0.8	
5.0HP		1965-68	B6S	0.8	
		1990-02	BR6HS	0.8	
	4 stroke (128cc)	1997-03	D6HA	0.7	
	4 stroke (138cc)	2003 on	BPR6ES	0.8	BPR6EIX
5.5HP		1954-64	B6S	0.8	
6.0HP		1965-76	B6S	0.8	
	Com	1977-02	BZ7HS-10	0.8	
	4 stroke	1997-03	D6HA	0.7	
6.5HP	Com	1981-93	BZ7HS-10	0.8	
7.5HP		1952-58	B6S	0.8	
	Com	1977-03	BZ7HS-10	0.8	
8.0HP		1977-02	BR6HS	0.8	
	4 stroke	1996-03	D6HA	0.7	
9.5HP		1964-73	B7S	0.8	
9.9HP		1974-76	B7HS	0.7	BR7HIX
		1977-02	BR7HS	0.8	BR7HIX
	Big Bore	1993-06	BR6HS	0.8	
	4 stroke (302cc)	2002-03	DCPR7E	0.8	DCPR7EIX
	4 stroke (305cc)	1995-03	DCPR7E	0.8	DCPR7EIX
	4 stroke (211cc)	1996-03	D6HA	0.7	
10HP		1952-58	B6S	0.8	
		1959-63	B7S	0.8	
	Com	1992-93	BZ7HS-10	0.8	
	Com	1994-03	BR7HS	0.8	BR7HIX
14HP	Com	1981-91	BZ7HS-10	0.8	
	Com	1988-89	BZ7HS-10	0.8	
15HP		1974-76	B7HS	0.7	BR7HIX
		1977-92	BZ7HS-10	0.8	
		1994-02	BR7HS	0.8	BR7HIX

Make & Model	Other	Year	Recommended Part No.	Gap (mm)	Iridium Option
15HP	Big Bore	1993-06	BR6HS	0.8	
	Com	1992-93	BZ7HS-10	0.8	
	4 Stroke	1995-03	DCPR7E	0.8	DCPR7EIX
	Kero	1995-02	BUHXW-1	1.3	
18HP		1957-73	B7S	0.8	
	Jet (25HP)	1995-02	BZ7HS-10	0.8	
20HP		1966-73	B7S	0.8	
		1978-06	BZ7HS-10	0.8	
25HP	(2 cyl)	1977-98	BR7HS	0.8	BR7HIX
		1969-76	B7S	0.8	
		1977	BR7HS	0.8	BR7HIX
		1978-06	BZ7HS-10	0.8	
	Com	1981-02	BUZ8H	1.55	
	(3 cyl)	1995-97	BR6HS	0.8	
	(3 cyl)	1998-02	BR7HS	0.8	BR7HIX
	4 Stroke	2000-02	DCPR6E	0.8	DCPR6EIX
28HP		1962-64	B7S	0.8	
	(2 cyl)	1978-06	BZ7HS-10	0.8	
	Jet (40HP)	1992-03	BPZ8HS-10	0.8	
30HP		1956-71	B7S	0.8	
	(2 cyl)	1978-06	BZ7HS-10	0.8	
	4 Stroke	2000-03	DCPR7E	0.8	DCPR7EIX
33HP		1965-71	B7S	0.8	
35HP		1957-59	B7HS	0.7	BR7HIX
		1976	B7HS	0.7	BR7HIX
	(2 cyl)	1978-06	BZ7HS-10	0.8	
	(3 cyl)	1995-97	BR6HS	0.8	
	(3 cyl)	1998-02	BR7HS	0.8	BR7HIX
	Jet (50HP)	1993-02	BPZ8HS-10	0.8	
40HP	(2 cyl)	1980-88	BUHW-2	1.8	
	(2 cyl)	1989-05	BPZ8HS-10	0.8	
		1960-73	B7S	0.8	
		1974-76	B7HS	0.7	BR7HIX
	Com (43 cu. in)	1981-90	B7HS	0.7	BR7HIX
	Com (45 cu. in)	1984-03	BUHXW-1	1.3	
	4 stroke (815cc)	1999-03	DCPR7E	0.8	DCPR7EIX
E-Tec 40 Inline2	2006-2007	IZFR6N-E	0.8		
45HP	Com	1986-90	BUZHW-2	1.8	
	Com	1991-02	BUHXW-1	1.3	
		1986-05	BUZ8H	1.55	
48HP	(2 cyl)	1980-88	BUHW-2	1.8	
	(2 cyl)	1989-02	BPR7HS	0.8	BPR7HIX
	(2 cyl)	1989-05	BPZ8HS-10	0.8	
50HP		1971-75	B7HS-10	0.8	
	(2 cyl)	1980-88	BUHW-2	1.8	
	(2 cyl)	1989-05	BPZ8HS-10	0.8	
	(3 cyl)	1995-02	BPZ8HS-10	0.8	



MARINE – OUTBOARD RANGE

Make & Model	Other	Year	Recommended Part No.	Gap (mm)	Iridium Option
EVINRUDE (CONT)					
Note: "Z" type inductive suppressor plugs are recommended for all VRO and 60° Looper V engines					
50HP (cont)	4 stroke (815cc)	1999-03	DCPR7E	0.8	DCPR7EIX
	E-Tec 50 Inline2	2006-2007	IZFR6N-E	0.8	
55HP	(2 cyl)	1976-89	B7HS	0.7	BR7HIX
	(3 cyl)	1968-69	BUHW-2	1.8	
	Com	1986-03	BUHXW-1	1.3	
	Com 2Cyl	1994-95	BPZ8HS-10	1.0	
60HP	(2 cyl)	1980-85	BUHW-2	1.8	
	(3 cyl)	1970-71	BUHW	1.3	
	(3 cyl 49 cu. in)	1975-89	BZ7HS-10	0.8	
	(3 cyl 56 cu. in)	1989-93	BZ7HS-10	0.8	
	(3 cyl 56 cu. in)	1994-02	BPZ8HS-10	0.8	
	4 Stroke	2002-03	BPR6ES	0.8	BPR6EIX
	V4	1964-67	B7S	0.8	
	E-Tec 60 Inline2	2006-2007	IZFR6N-E	0.8	
65HP	V4	1968	BUHW	1.3	
	(3 cyl)	1972-73	B7HS	0.7	BR7HIX
	Com HC LC	1984-87	BUHW-2	1.8	
	Com HC LC	1988-02	BUZ8H	1.55	
	Jet (90° Cross V)	1992-02	BZ7HS-10	0.8	
70HP	(3 cyl 49 cu. in)	1975-89	BZ7HS-10	0.8	
	(3 cyl 56 cu. in)	1989-93	BZ7HS-10	0.8	
	(3 cyl 56 cu. in)	1994-02	BPZ8HS-10	0.8	
	4 Stroke	1998-03	BPR6ES	0.8	BPR6EIX
75HP	(3 cyl 49 cu. in)	1975-89	BZ7HS-10	0.8	
	V4	1960-65	B7S	0.8	
80HP		1966-67	B7S	0.8	
	Jet 88, 90, 110, 112, 115 (90° Cross V)	1979-02	BZ7HS-10	0.8	
85HP		1968-72	BUHW-2	1.8	
		1973-80	B7HS-10	0.8	
		1986-93	BZ7HS-10	0.8	
		1994-95	BR6HS	0.8	
90HP		1964-65	B7S	0.8	
	LV4 Ficht	1998-03	PZFR6H	0.8	
	4 stroke	2003 on	BKR6E	0.8	BKR6EIX
	E-Tec 1.3L I3	2006-2007	IZFR6N-E	0.8	
100HP		1966	B7S	0.8	
		1967-72	BUHW-2	1.8	
	Com	1984-02	BUZ8H	1.55	
105HP	Jet (60° Loop V)	1993-03	BPZ8HS-10	0.8	
	Com (60° Loop V)	1997-03	BPZ8HS-10	0.8	

Make & Model	Other	Year	Recommended Part No.	Gap (mm)	Iridium Option
115HP		1969-70	BUHW-2	1.8	
		1973-79	BUZ8H	1.55	
	CV4	1979-98	BZ7HS-10	1.0	
	LV4 Ficht	1998-03	PZFR6H	0.8	
	4 stroke	2003 on	BKR6E	0.8	BKR6EIX
	115 (60° Loop V)	1995-06	BPZ8HS-10	0.8	
	115 Turbojet (90° Cross V)	1994-02	BZ7HS-10	0.8	
120HP	E-Tec 1.7L V4	2007	IZFR6N-E	0.8	
	(90° Loop V)	1985-03	BPZ8HS-10	0.8	
125HP		1971-72	BUHW	1.3	
130HP	(90° Loop V)	1985-03	BPZ8HS-10	0.8	
135HP		1973-84	BUZ8H	1.55	
140HP		1973-84	BUZ8H	1.55	
	(90° Loop V)	1985-03	BPZ8HS-10	0.8	
	4 stroke	2003 on	BKR6E	0.8	BKR6EIX
150HP	Com (60° Loop V)	1993-02	BPZ8HS-10	0.8	
	(60° Loop V)	1991-02	BPZ8HS-10	0.8	
	(90° Cross V)	1978-87	BUZ8H	1.55	
	(90° Cross V)	1988-91	BZ7HS-10	0.8	
	LV6 Ficht	1997-03	PZFR6H	0.8	
	E-Tec 150 HO V6	2007	IZFR6N-E	0.8	
	E-Tec 150 I V6	2007	IZFR6N-E	0.8	
155HP	(90° Cross V)	1978-87	BUZ8H	1.55	
	Com (90° Cross V)	1989-92	BUZ8H	1.55	
175HP		1977-87	BUZ8H	1.55	
	(90° Cross V)	1988-91	BZ7HS-10	0.8	
	(60° Loop V)	1991-06	BPZ8HS-10	0.8	
	LV6 Ficht	1998-03	PZFR6H	0.8	
	E-Tec 175 I V6	2007	IZFR6N-E	0.8	
185HP		1977-87	BUZ8H	1.55	
	Com	1990-93	BUZ8H	1.55	
200HP		1976-83	BUZ8H	1.55	
		1986-93	BZ7HS-10	0.8	
		1994-02	BPZ8HS-10	0.8	
	Com	1992	BUZ8H	1.55	
	Com	1993-02	BPZ8HS-10	0.8	
	DCXSOC	2005	IZFR6N-E	0.8	
	DHLSOC	2005	IZFR6N-E	0.8	
	DHLSOG	2005	IZFR6N-E	0.8	
	DPLSOC	2005	IZFR6N-E	0.8	
	DPXSOC	2005	IZFR6N-E	0.8	
	DSLLOC	2005	IZFR6N-E	0.8	
	DHLSDF	2006	IZFR6N-E	0.8	
	DHXSOS	2006	IZFR6N-E	0.8	
HXSOS	2006	IZFR6N-E	0.8		

EVINRUDE (CONT)

Note: "Z" type inductive suppressor plugs are recommended for all VRO and 60° Looper V engines

Make & Model	Other	Year	Recommended Part No.	Gap (mm)	Iridium Option	
200HP (cont)	HSLSDS	2006	IZFR6N-E	0.8		
	E-Tec 200 I V6 60°	2007	IZFR6N-E	0.8		
	LV6 Ficht	1999-03	PZFR6H	0.8		
225HP	DCXSOC	2005	IZFR6N-E	0.8		
	DCZSOC	2005	IZFR6N-E	0.8		
	DHLSOC	2005	IZFR6N-E	0.8		
	DHLSOF	2005	IZFR6N-E	0.8		
	DHLSOG	2005	IZFR6N-E	0.8		
	DHXSOC	2005	IZFR6N-E	0.8		
	DHXSOG	2005	IZFR6N-E	0.8		
	DPLSOC	2005	IZFR6N-E	0.8		
	DPXSOC	2005	IZFR6N-E	0.8		
	DPZSOC	2005	IZFR6N-E	0.8		
	DCXSDR	2006	IZFR6N-E	0.8		
	DCZSDR	2006	IZFR6N-E	0.8		
	DHLSDF	2006	IZFR6N-E	0.8		
	DPLSDR	2006	IZFR6N-E	0.8		
	DPXSDR	2006	IZFR6N-E	0.8		
	DPZSDR	2006	IZFR6N-E	0.8		
			1986-93	BZ7HS-10	0.8	
			1994-02	BPZ8HS-10	0.8	
		LV6 Ficht	1999-03	PZFR6H	0.8	
	235HP		1978-85	BUZ8H	1.55	
250HP	LV6 Fict	2000-03	PZFR6H	0.8		
	DCXSOC	2005	IZFR6N-E	0.8		
	DCZSOC	2005	IZFR6N-E	0.8		
	DPLSOC	2005	IZFR6N-E	0.8		
	DPXSOC	2005	IZFR6N-E	0.8		
	DPZSOC	2005	IZFR6N-E	0.8		
	DCXSDR	2006	IZFR6N-E	0.8		
	DCZSDR	2006	IZFR6N-E	0.8		
	DPLSDR	2006	IZFR6N-E	0.8		
	DPXSDR	2006	IZFR6N-E	0.8		
DPZSDR	2006	IZFR6N-E	0.8			
250HP V8		1985-02	BPZ8HS-10	0.8		
275HP		1985-88	BPZ8HS-10	0.8		
300HP V8		1985-02	BPZ8HS-10	0.8		
3.6L		1985-86	BZ7HS-10	0.8		
OMC	Sea Drive	1988-92	BZ7HS-10	0.8		

FORCE (U.S. MARINE)

2 HP		1996-98	B7HS	0.7	BR7HIX
3 HP		1990-94	BP6HS-10	1.0	BPR6HIX
4 HP		1984-87	B6HS	0.8	BR6HIX
5 HP		1988-98	B6HS	0.8	BR6HIX
7.5 HP		1985	B6HS	0.8	BR6HIX

Make & Model	Other	Year	Recommended Part No.	Gap (mm)	Iridium Option
9.9 HP		1984-98	BP7HS	0.8	BPR7HIX
15 HP		1984-98	BP7HS	0.8	BPR7HIX
25 HP		1996-98	B7HS	0.7	BR7HIX
35 HP		1986-91	B6HS-10	1.0	
40 HP		1992-98	BUZHW	1.3	
50 HP		1984-87	B7HS	0.7	BR7HIX
	Thunderbolt Ign	1991-98	BUZHW	1.3	
	Prestolite Ign	1988-91	BUHX	0.75	
60 HP		1985	BUZHW	1.3	
70 HP	Thunderbolt Ign	1991-95	BUZHW	1.3	
75 HP		1996-98	BUZHW	1.3	
85 HP		1983-89	BUHX	0.75	
90 HP	Thunderbolt Ign	1991-98	BUZHW	1.3	
	Prestolite Ign	1990-91	BUHX	0.75	
120 HP	Thunderbolt Ign	1991-98	BUZHW	1.3	
	Prestolite Ign	1990-91	BUHX	0.75	
125HP		1983-89	BUHX	0.75	
150 HP	Thunderbolt Ign	1991-94	BUZHW	1.3	
	Prestolite	1989-91	BUHX	0.75	

HANIMEX

4.5, 5.5, 7.5HP			BP5S	0.8	XR5IX
9.9, 15HP			B6S	0.8	

HONDA

2 HP BF2D2	1 Cyl, 1 Carb, 57cc, 4 Stroke		CR4HSB	0.7	
2 HP BF2D4	1 Cyl, 1 Carb, 57cc, 4 Stroke		CR4HSB	0.7	
2.3 HP BF2.3D4	1 Cyl, 1 Carb, 57 cc, 4 Stroke		CR4HSB	0.7	
2.3 HP BF2.3DK2	1 Cyl, 1 Carb, 57 cc, 4 Stroke		CR4HSB	0.7	
5 HP BF5A2	1 Cyl, 1 Carb, 127 cc, 4 Stroke		BPR5ES	0.9	BPR5EIX
5 HP BF5A4	1 Cyl, 1 Carb, 127 cc, 4 Stroke		BPR5ES	0.9	BPR5EIX
5 HP BF5AK2	1 Cyl, 1 Carb, 127 cc, 4 Stroke		BPR5ES	0.9	BPR5EIX
5 HP BF5DK2SB	1 Cyl, Carb, 127 cc, 4 Stroke		BPR5ES	0.9	BPR5EIX
8 HP BF8D1	2 Cyl, 1 Carb, 222 cc, 4 Stroke		CR5EH-9	0.9	
8 HP BF8D2	2 Cyl, 1 Carb, 222 cc, 4 Stroke		CR5EH-9	0.9	
8 HP BF8DK2	2 Cyl, Carb, 222 cc, 4 Stroke		CR5EH-9	0.9	
10 HP BF10S1	2 Cyl, 1 Carb, 222 cc, 4 Stroke		CR5EH-9	0.9	



MARINE – OUTBOARD RANGE

Make & Model	Other	Year	Recommended Part No.	Gap (mm)	Iridium Option
HONDA (CONT)					
10 HP BF10D2	2 Cyl, 1 Carb, 222 cc, 4 Stroke		CR5EH-9	0.9	
10 HP BF10DK2	2 Cyl, Carb, 222 cc, 4 Stroke		CR5EH-9	0.9	
15 HP BF15AX	2 Cyl, 1 Carb, 350 cc, 4 Stroke		DR6HS	0.7	
15 HP BF15D3	2 Cyl, 1 Carb, 350 cc, 4 Stroke		CR5EH-9	0.9	
15 HP BF15DK2	2 Cyl, Carb, 350 cc, 4 Stroke		CR5EH-9	0.9	
20 HP BF20A2	2 Cyl, 1 Carb, 350 cc, 4 Stroke		DR7EB	0.7	
20 HP BF20D3	2 Cyl, 1 Carb, 350 cc, 4 Stroke		CR5EH-9	0.9	
20 HP BF20DK2	2 Cyl, 1 Carb, 350 cc, 4 Stroke		CR5EH-9	0.9	
25 HP BF25A2	3 Cyl, 3 Carb, 499 cc, 4 Stroke		DR7EA	0.7	
25 HP BF25D4	3 Cyl, 3 Carb, 552 cc, 4 Stroke		DR7EA	0.7	
25 HP BF25DK2	3 Cyl, Carb, 552 cc, 4 Stroke		DR7EA	0.7	
30 HP BF30A2	3 Cyl, 3 Carb, 499 cc, 4 Stroke		DR7EA	0.7	
30 HP BF30D4	3 Cyl, 3 Carb, 552 cc, 4 Stroke		DR7EA	0.7	
30 HP BF30DK2	3 Cyl, Carb, 552 cc, 4 Stroke		DR7EA	0.7	
40 HP BF40A2	3 Cyl, 3 Carb, 808 cc, 4 Stroke		DR7EA	0.7	
40 HP BF40A4	3 Cyl, 3 Carb, 808 cc, 4 Stroke		DR7EA	0.7	
40 HP BF40D	3 Cyl, 3 Carb, 808 cc, 4 Stroke		DR7EB	0.7	
40 HP BF40DK2	3 Cyl, PGMFI, 808 cc, 4 Stroke		DR7EB	0.7	
50 HP BF50A2	3 Cyl, 3 Carb, 808 cc, 4 Stroke		DR7EA	0.7	
50 HP BF50A4	3 Cyl, 3 Carb, 808 cc, 4 Stroke		DR7EA	0.7	
50 HP BF50D	3 Cyl, 3 Carb, 808 cc, 4 Stroke		DR7EB	0.7	
50 HP BF50DK2	3 Cyl, PGMFI, 808 cc, 4 Stroke		DR7EB	0.7	
60 HP BF60A	3 Cyl, EFI, 998 cc, 4 Stroke		LMAR6C-9	0.9	
60 HP BFP60A	3 Cyl, EFI, 998 cc, 4 Stroke		LMAR6C-9	0.9	
60 HP BF60AK1	3 Cyl, PGMFI, 998 cc, 4 Stroke		LMAR6C-9	0.9	
60 HP BFP60AK1	3 Cyl, PGMFI, 998 cc, 4 Stroke		LMAR6C-9	0.9	

Make & Model	Other	Year	Recommended Part No.	Gap (mm)	Iridium Option
75 HP BF75A	4 Cyl, 4 Carb, 1590 cc, 4 Stroke		DR7EA	0.7	
75 HP BF75A2	4 Cyl, 4 Carb, 1590 cc, 4 Stroke		DR7EA	0.7	
75 HP BF75D	4 Cyl, 4 Carb, 1496 cc, 4 Stroke		IZFR6K-11E	1.1	
75 HP BF75DK2	4 Cyl, PGMFI, 1496 cc, 4 Stroke		IZFR6K-11E	1.1	
90 HP BF90A	4 Cyl, 4 Carb, 1590 cc, 4 Stroke		DR7EA	0.7	
90 HP BF90A2	4 Cyl, PGMFI, 1496 cc, 4 Stroke		DR7EA	0.7	
90 HP BF90D	4 Cyl, PGMFI, 1496 cc, 4 Stroke		IZFR6K-11E	1.1	
90 HP BF90DK2	4 Cyl, PGMFI, 1496 cc, 4 Stroke		IZFR6K-11E	1.1	
115 HP BF115AX	4 Cyl, EFI, 2254 cc, 4 Stroke		ZFR7F	0.8	
115 HP BF115A2	4 Cyl, EFI, 2254 cc, 4 Stroke		ZFR7F-11	1.1	
115 HP BF115D	4 Cyl, EFI, 2254 cc, 4 Stroke		ZFR6K-11	1.1	IZFR6K11
115 HP BF115DK1	4 Cyl, PGMFI, 2354 cc, 4 Stroke		ZFR6K-11	1.1	IZFR6K11
130 HP BF130AX	4 Cyl, EFI, 2254 cc, 4 Stroke		ZFR7F	0.8	
130 HP BF130A2	4 Cyl, EFI, 2254 cc, 4 Stroke		ZFR7F-11	1.1	
135 HP BF135A4	4 Cyl, EFI, 2354 cc, 4 Stroke		IZFR6K11	1.1	
135 HP BF135AK2	4 Cyl, PGMFI, 2354 cc, 4 Stroke		ZFR6K-11	1.1	IZFR6K11
150 HP BF150A4	4 Cyl, EFI, 2354 cc, 4 Stroke		IZFR6K11	1.1	
150 HP BF150AK2	4 Cyl, PGMFI, 2354 cc, 4 Stroke		ZFR6K-11	1.1	IZFR6K11
175 HP BF175A3	V6 Cyl, EFI, 3471 cc, 4 Stroke		IZFR6F11	1.1	
175 HP BF175A6	V6 Cyl, EFI, 3471 cc, 4 Stroke		IZFR6F11	1.1	
175 HP BF175AK1	V6 Cyl, EFI, 3471 cc, 4 Stroke		IZFR6F11	1.1	
175 HP BF175AK2	V6 Cyl, PGMFI, 3471 cc, 4 Stroke		IZFR6F11	1.1	
200 HP BF200A2	V6 Cyl, EFI, 3471 cc, 4 Stroke		IZFR6F11	1.1	
200 HP BF200A6	V6 Cyl, EFI, 3471 cc, 4 Stroke		IZFR6F11	1.1	
200 HP BF200AK1	V6 Cyl, EFI, 3471 cc, 4 Stroke		IZFR6F11	1.1	
200 HP BF200AK2	V6 Cyl, PGMFI, 3471 cc, 4 Stroke		IZFR6F11	1.1	
225 HP BF225A2	V6 Cyl, EFI, 3471 cc, 4 Stroke		IZFR6F11	1.1	

Make & Model	Other	Year	Recommended Part No.	Gap (mm)	Iridium Option
HONDA (CONT)					
225 HP BF225A6	V6 Cyl, EFI, 3471 cc, 4 Stroke		IZFR6F11	1.1	
225 HP BF225AK1	V6 Cyl, EFI, 3471 cc, 4 Stroke		IZFR6F11	1.1	
225 HP BF225AK2	V6 Cyl, PGMFI, 3471 cc, 4 Stroke		IZFR6F11	1.1	
250 HP BF250A	V6 Cyl, PGMFI, 3583 cc, 4 Stroke		ZFR6K-11E	1.1	IZFR6K-11E

JOHNSON

Note: "Z" type inductive suppressor plugs are recommended for all VRO and 60° Loop V engines

1.0HP	1R	1968-70	B6S	0.8	
1.1HP		1946-47	B-4L	0.8	
1.2HP	Magneto	1986-90	B6S	0.8	
1.5HP		1968-70	B6S	0.8	
2.0HP	Excel 4, Ultra	1987-88	B7HS	0.7	BR7HIX
	Jr. Colt	1971-90	BR6S	0.8	
	Aquanaut Driving Unit	1966-70	BM4A	0.8	
	2R	1971-84	B6S	0.8	
	1-Cyl	1991-02	BPR6HS	0.8	BPR6HIX
		1968-70	B6S	0.8	
2.3HP	1-Cyl	1991-02	BPR6HS	0.8	BPR6HIX
2.5HP		1987-88	BZ7HS-10	0.8	
3-5.2HP	Lighttwin	1952-74	B6S	0.8	
3.0HP		1952-68	B6S	0.8	
	2-Cyl	1989-97	BR6HS	0.8	
3.3HP	1-Cyl	1991-03	BPR6HS	0.8	BPR6HIX
3.5HP		2001-06	BPR6HS	0.8	BPR6HIX
4.0HP		1969-76	B6S	0.8	
		1977-87	BR6HS	0.8	
	Ultra, Excel	1987-88	BZ7HS-10	0.8	
		1988 on	BZ7HS-10	0.8	
		1989-03	BR6HS	0.8	
4.5HP		1980-85	BR6HS	0.8	
5.0HP		1965-68	B6S	0.8	
		1990-02	BR6HS	0.8	
	4 stroke	1997-03	D6HA	0.7	
		1998 on	BZ7HS-10	0.8	
5.5HP		1954-64	B6S	0.8	
6.0HP		1965-76	B6S	0.8	
	Com	1977-02	BZ7HS-10	0.8	
	4 stroke	1997-03	D6HA	0.7	
6.5HP	Com	1981-93	BZ7HS-10	0.8	
7.5HP		1952-58	B6S	0.8	
	Com	1977-02	BZ7HS-10	0.8	
8.0HP		1977-02	BR6HS	0.8	
		1977-97	BR6HS	0.8	
	4 stroke	1996-03	D6HA	0.7	

8.0HP	2 stroke	1998 on	BR6HS	0.8	
	4 stroke SOHC	2002 on	DR5HS	0.7	
9.5HP		1964-73	B7S	0.8	
9.9HP		1974-76	B7HS	0.7	BR7HIX
		1977-02	BZ7HS-10	0.8	
	Big Bore	1993-02	BR6HS	0.8	
	4 stroke (305cc)	1995-03	DCPR7E	0.8	DCPR7EIX
	4 stroke (302cc)	2002-03	DCPR7E	0.8	DCPR7EIX
	2-Stroke SOHC	2002-03	DCPR7E	0.8	DCPR7EIX
	2-Stroke OHC	1977-01	BR7HS	0.8	BR7HIX
10HP		1952-58	B6S	0.8	
		1959-63	B7S	0.8	
	Com	1992-93	BZ7HS-10	0.8	
	Com	1994-03	BR7HS	0.8	BR7HIX
14HP	Com	1981-91	BZ7HS-10	0.8	
	Com	1988-89	BZ7HS-10	0.8	
15HP		1974-76	B7HS	0.7	BR7HIX
		1977-92	BZ7HS-10	0.8	
		1994-02	BR7HS	0.8	BR7HIX
	Big Bore	1993-02	BR6HS	0.8	
	Com	1992-93	BZ7HS-10	0.8	
	4 Stroke	1995-03	DCPR7E	0.8	DCPR7EIX
	Kero	1995-02	BUHXW-1	1.3	
18HP		1957-73	B7S	0.8	
	Jet (25HP)	1995-02	BZ7HS-10	0.8	
20HP		1966-73	B7S	0.8	
		1978-02	BR7HS	0.8	BR7HIX
25HP	(2 cyl)	1977-98	BR7HS	0.8	BR7HIX
		1969-76	B7S	0.8	
		1977	BR7HS	0.8	BR7HIX
		1978-02	BZ7HS-10	0.8	
	Com	1981-02	BUZ8H	1.55	
	(3 cyl)	1995-97	BR6HS	0.8	
	(3 cyl)	1998-02	BR7HS	0.8	BR7HIX
	4 Stroke	2000-02	DCPR6E	0.8	DCPR6EIX
28HP		1962-64	B7S	0.8	
	(2 cyl)	1978-02	BR7HS	0.8	BR7HIX
	Jet (40HP)	1992-03	BPZ8HS-10	0.8	
30HP		1956-71	B7S	0.8	
	(2 cyl)	1978-02	BR7HS	0.8	BR7HIX
	4 Stroke	2000-03	DCPR6E	0.8	DCPR6EIX
33HP		1965-71	B7S	0.8	
35HP		1957-59	B7HS	0.7	BR7HIX
		1976	B7HS	0.7	BR7HIX
	(2 cyl)	1977-02	BZ7HS-10	0.8	
	(3 cyl)	1995-97	BR6HS	0.8	
	(3 cyl)	1998-02	BR7HS	0.8	BR7HIX
	Jet (50HP)	1993-03	BPZ8HS-10	0.8	



MARINE – OUTBOARD RANGE

Make & Model	Other	Year	Recommended Part No.	Gap (mm)	Iridium Option
JOHNSON (CONT)					
Note: "Z" type inductive suppressor plugs are recommended for all VRO and 60° Loop V engines					
40HP	(2 cyl)	1980-88	BUHW-2	1.8	
	(2 cyl)	1989-02	BPZ8HS-10	0.8	
		1960-73	B7S	0.8	
		1974-76	B7HS	0.7	BR7HIX
	Com (43 cu. in)	1981-90	B7HS	0.7	BR7HIX
	Com (45 cu. in)	1984-03	BUHXW-1	1.3	
45HP	Com	1986-90	BUZHW-2	1.8	
	Com	1991-02	BUHXW-1	1.3	
48HP	(2 cyl)	1980-88	BUHW-2	1.8	
	(2 cyl)	1989-02	BPR7HS	0.8	BPR7HIX
50HP		1971-75	B7HS-10	0.8	
	(2 cyl)	1980-88	BUHW-2	1.8	
	(2 cyl)	1989-02	BPZ8HS-10	0.8	
	(3 cyl)	1995-02	BPZ8HS-10	0.8	
	4 stroke (815cc)	1999-02	DCPR7E	0.8	DCPR7EIX
55HP	(2 cyl)	1976-89	BUHW-2	1.8	
	(3 cyl)	1968-69	BUHW-2	1.8	
	Com	1986-03	BUHXW-1	1.3	
60HP	(2 cyl)	1980-85	BUHW-2	1.8	
	(3 cyl)	1970-71	BUHW	1.3	
	(3 cyl 49 cu. in)	1975-89	BZ7HS-10	0.8	
	(3 cyl 56 cu. in)	1989-93	BZ7HS-10	0.8	
	(3 cyl 56 cu. in)	1994-02	BPZ8HS-10	0.8	
	4-Stroke COM	2002-03	BPR6ES	0.8	BPR6EIX
	V4	1964-67	B7S	0.8	
65HP	V4	1968	BUHW	1.3	
	(3 cyl)	1972-73	B7HS	0.7	BR7HIX
	Com HC LC	1984-87	BUHW-2	1.8	
	Com HC LC	1988-03	BUHXW-1	1.3	
	Jet (90° Cross V)	1992-02	BZ7HS-10	0.8	
70HP	(3 cyl 49 cu. in)	1975-89	BZ7HS-10	0.8	
	(3 cyl 56 cu. in)	1989-93	BZ7HS-10	0.8	
	(3 cyl 56 cu. in)	1994-02	BPZ8HS-10	0.8	
	4 Stroke	1998-02	BPR6ES	0.8	BPR6EIX
75HP	(3 cyl 49 cu. in)	1975-89	BZ7HS-10	0.8	
	V4	1960-65	B7S	0.8	
80HP		1966-67	B7S	0.8	
	Jet 88, 90, 110, 112, 115 (90° Cross V)	1979-02	BZ7HS-10	0.8	

Make & Model	Other	Year	Recommended Part No.	Gap (mm)	Iridium Option
85HP		1968-72	BUHW-2	1.8	
		1973-80	B7HS-10	0.8	
		1986-93	BZ7HS-10	0.8	
		1994-95	BR6HS	0.8	
90HP		1964-65	B7S	0.8	
	115 (60° Loop V)	1995-02	BPZ8HS-10	0.8	
	115 Turbojet (90° Cross V)	1994-02	BZ7HS-10	0.8	
	LV4 Ficht	1998-03	PZFR6H	0.8	
	1950cc	2003 on	BKR6E	0.7	BKR6EIX
100HP		1966	B7S	0.8	
		1967-72	BUHW-2	1.8	
	Com	1984-02	BUZ8H	1.55	
105HP	Jet (60° Loop V)	1993-03	BPZ8HS-10	0.8	
	Com (60° Loop V)	1997-03	BPZ8HS-10	0.8	
115HP		1969-70	BUHW-2	1.8	
		1973-79	BUZ8H	1.55	
	CV4	1979-98	BZ7HS-10	1.0	
	LV4 Ficht	1998-03	PZFR6H	0.8	
120HP	(90° Loop V)	1985-03	BPZ8HS-10	0.8	
125HP		1971-72	BUHW	1.3	
130HP	(90° Loop V)	1985-03	BPZ8HS-10	0.8	
135HP		1973-84	BUZ8H	1.55	
140HP		1973-84	BUZ8H	1.55	
	(90° Loop V)	1985-03	BPZ8HS-10	0.8	
150HP	Com (60° Loop V)	1993-02	BPZ8HS-10	0.8	
	(60° Loop V)	1991-02	BPZ8HS-10	0.8	
	(90° Cross V)	1978-87	BUZ8H	1.55	
	(90° Cross V)	1988-91	BZ7HS-10	0.8	
	LV6 Ficht	1997-03	PZFR6H	0.8	
	(90° Cross V)	1978-87	BUZ8H	1.55	
155HP	(90° Cross V)	1978-87	BUZ8H	1.55	
	Com (90° Cross V)	1989-92	BUZ8H	1.55	
175HP		1977-87	BUZ8H	1.55	
	(90° Cross V)	1988-91	BZ7HS-10	0.8	
	(60° Loop V)	1991-02	BPZ8HS-10	0.8	
	LV6 Ficht	1998-03	PZFR6H	0.8	
185HP		1977-87	BUZ8H	1.55	
	Com	1990-93	BUZ8H	1.55	
200HP		1976-83	BUZ8H	1.55	
		1986-93	BZ7HS-10	0.8	
		1994-02	BPZ8HS-10	0.8	
	Com	1992	BUZ8H	1.55	
	Com	1993-02	BPZ8HS-10	0.8	
	LV6 Ficht	1999-03	PZFR6H	0.8	
	Venom LV6	1994-03	BPZ8HS-10	0.8	
225HP		1986-93	BZ7HS-10	0.8	
		1994-02	BPZ8HS-10	0.8	



Make & Model	Other	Year	Recommended Part No.	Gap (mm)	Iridium Option
JOHNSON (CONT)					
Note: "Z" type inductive suppressor plugs are recommended for all VRO and 60° Loop V engines					
225HP (cont)	LV6 Ficht	1999-03	PZFR6H	0.8	
	Venom LV6	1994-03	BPZ8HS-10	0.8	
235HP		1978-85	BUZ8H	1.55	
250HP	LV6 Ficht	2000-03	PZFR6H	0.8	
250HP, 300HP V8		1985-02	BPZ8HS-10	0.8	
275HP		1985-88	BPZ8HS-10	0.8	
3.6L		1985-86	BZ7HS-10	0.8	
OMC	Sea Drive	1988-92	BZ7HS-10	0.8	

MARINER/MERCURY						
Engine	Model	Serial # Start	Serial # End	Recommended Spark Plug	Gap (mm)	Iridium Option
2 HP	2A (M) 646	ALL	ALL	B6HS	0.6	BR6HIX
	2B (M) 6A1	101	11600	B6HS	0.6	BR6HIX
	2B (M) 6A1	11601		B5HS	0.6	
2.2 HP	2.2	8075603		BPR6HS-10	1	BPR6HIX
2.5 HP	2.5	0A855097		BP6HS-10	1	BPR6HIX
	2.5 FourStroke	0R131842		DCPR6E	0.8	DCPR6EIX
3.5 HP	3.5 (M) 642	0	23740	B7HS	0.6	BR7HIX
	3.5 (ML) 642	0	41690	B7HS	0.6	BR7HIX
	3.5 (M) 642	23741		B6HS	0.6	BR6HIX
	3.5 (ML) 642	41691		B6HS	0.6	BR6HIX
3 HP	3	0A855097	0G710612	BPR6HS-10	1	BPR6HIX
3.3 HP	3.3	0D901217		BP6HS-10	1	BPR6HIX
3.5 HP	3.5	6202173		BP6HS-10	1	BPR6HIX
	3.5 FourStroke	0R131842		DCPR6E	0.8	DCPR6EIX
3.6 HP	3.6	5404657		BP7HS-10	1	BPR7HIX
	3.6	9252831		BP7HS-10	1	BPR7HIX
	3.6	7145388		BP7HS-10	1	BPR7HIX
3.9 HP	3.9 (39)	1655013	2498135	B5HS	0.7	
4 HP	4A (M, ML) 6E0	ALL	ALL	B7HS	0.6	BR7HIX
	4 (40)(1 cyl.)	2498136	2771621	B5HS	0.8	
	4 (40)(1 cyl.)	2771622	0A809600	BUHW-2	1.8	
	4 (40)(2 cyl.) Gnat	9075839	9256980	B6HS	0.7	BR6HIX
	4 (40)(2 cyl.) Gnat	7085673	7146487	B6HS	0.7	BR6HIX
	4 (40)(2 cyl.)	5589202	5595531	BP7HS-10	1	BPR7HIX
	4 (40)(2 cyl.)	8065265	8068064	BP7HS-10	1	BPR7HIX
	4 (40)(2 cyl.)	9256981	9258280	BP7HS-10	1	BPR7HIX
	4 (40)(2 cyl.)	7146488	7143687	BP7HS-10	1	BPR7HIX
	4 (1 cyl.)	0A809601		BP7HS-10	1	BPR7HIX
	4 (1 cyl.)	9477830		BP7HS-10	1	BPR7HIX
	4 FourStroke	0R000001		DCPR6E	0.9	DCPR6EIX
	4 FourStroke	0P073456		DCPR6E	0.9	DCPR6EIX
4.5 HP	4.5 (45)(1 cyl.)	4107220	0A809600	BUHW-2	1.8	
	4.5 (45)(1 cyl.)	8026540		BUHW-2	1.8	

Engine	Model	Serial # Start	Serial # End	Recommended Spark Plug	Gap (mm)	Iridium Option	
4.5 HP	4.5 (45)(1 cyl.)	9072179	9477829	BUHW-2	1.8		
	4.5 (45)(1 cyl.)	7045758		BUHW-2	1.8		
5 HP	5A (M, ML) 661	ALL	ALL	B7HS	0.6	BR7HIX	
	5C (M, ML) 6E3	ALL	ALL	B7HS	0.6	BR7HIX	
	5 (1 cyl.)	0A809601		BP7HS-10	1	BPR7HIX	
	5 (1 cyl.)	9477830		BP7HS-10	1	BPR7HIX	
	5 FourStroke	0R000001		DCPR6E	0.9	DCPR6EIX	
	5 FourStroke	0P073456		DCPR6E	0.9	DCPR6EIX	
6 HP	6C (M, ML) 6H8	ALL	ALL	B7HS-10	1		
	6D (M, ML) 6H6	ALL	ALL	B7HS-10	1		
	6 (60)	1408611	2126763	B6S	0.7		
	6 (60)	1958792	2096170	B6S	0.7		
	6 (60)(60J)	2126764		B6HS	0.8	BR6HIX	
	6 (60)(60J)	2096171		B6HS	0.8	BR6HIX	
	6	0A197112	0T800749	BP8H-N-10	1		
	6	9461526		BP8H-N-10	1		
	6 FourStroke	0R000001		DCPR6E	0.9	DCPR6EIX	
	6 FourStroke	0P073456		DCPR6E	0.9	DCPR6EIX	
	7.5 HP	7.5 (75)	2529895	3801457	BUHW-2	1.8	
		7.5 (75)	3801458	4851692	BUHW	1.3	
		7.5 (75)	8015315	8051349	BUHW	1.3	
7.5 (75)		9043194	9181725	BUHW	1.3		
7.5 (75)		7028598	7111897	BUHW	1.3		
7.5 (75)		4851693	5226934	BUHW-2	1.8		
7.5 (75)		8051350	8058019	BUHW-2	1.8		
7.5 (75)		9181726	9219255	BUHW-2	1.8		
7.5 (75)		7111898	7136037	BUHW-2	1.8		
7.5		5206550		B9HS-10	1		
7.5		8057545		B9HS-10	1		
7.5		9217756		B9HS-10	1		
7.5		7125388		B9HS-10	1		
8 HP		8A (M, ML) 655	ALL	ALL	B6HS	0.6	BR6HIX
	8B (M, ML) 677	ALL	ALL	B7HS	0.6	BR7HIX	
	W8(M, ML) 677	ALL	ALL	B7HS	0.6	BR7HIX	
	8 Marathon 677	ALL	ALL	B7HS	0.6	BR7HIX	
	K8 (M, ML) 680	ALL	ALL	B6HS	0.6	BR6HIX	
	8C (M, ML, MUL) 6G1	ALL	ALL	B7HS-10	1		
	8	0A197112		BP8H-N-10	1		
	8	9461526		BP8H-N-10	1		
	8 FourStroke Bodensee	0H000058	0H017349	CR6HSA	0.7	CR6HIX	
	8 FourStroke Bodensee	0G760300	0T178499	CR6HSA	0.7	CR6HIX	
	8 FourStroke Bodensee	0P086824	0P325499	DPR6EA-9	0.9		
	8 FourStroke	0R042475		DCPR6E	0.8	DCPR6EIX	
	8 FourStroke	0P325500		DCPR6E	0.8	DCPR6EIX	
9.8 HP	9.8 (110)	1470349	2098351	B6S	0.7		
	9.8 (110)	2098352	2798056	B7HS	0.8	BR7HIX	
	9.8 (110)	2798057	3795657	BUHW-2	1.8		



MARINE – OUTBOARD RANGE

MARINER/MERCURY (CONT)

Engine	Model	Serial # Start	Serial # End	Recommended Spark Plug	Gap (mm)	Iridium Option	Engine	Model	Serial # Start	Serial # End	Recommended Spark Plug	Gap (mm)	Iridium Option
9.8 HP (cont)	9.8 (110)	3795658	4839253	BUHW	1.3		15 HP	W15B 684	ALL	ALL	B7HS	0.6	BR7HIX
	9.8 (110)	8015040	8050624	BUHW	1.3			W15(Marathon) (M,ML, MUL) 684	ALL	ALL	B7HS-10	1	
	9.8 (110)	9041439	9165304	BUHW	1.3			K15 (M, ML) 669	ALL	ALL	B6HS	0.6	BR6HIX
	9.8 (110)	7027323	7111347	BUHW	1.3			K15 (M, ML) 6K4	ALL	ALL	B7HS-10	1	
	9.8 (110)	4839254	5206549	BUHW-2	1.8			K15 (M, ML) 6M7	ALL	ALL	B7HS-10	1	
	9.8 (110)	8050625	8057544	BUHW-2	1.8			15 (150)	1290910	1499331	B6S	0.7	
	9.8 (110)	9165303	9217755	BUHW-2	1.8			15	0B292414		BP8HS-15	1.5	
	9.8 (110)	7111348	7125387	BUHW-2	1.8			15	9542620		BP8HS-15	1.5	
	9.8	5206550		B9HS-10	1			15 Sea Pro/ Marathon	0G044365	0G437999	BP8H-N-10	1	
	9.8	8057545		B9HS-10	1			15 Sea Pro/ Marathon	0G438000		BP8HS-15	1.5	
	9.8	9217756		B9HS-10	1			15 Sea Pro/ Marathon	9927000		BP8HS-15	1.5	
	9.8	7125388		B9HS-10	1			15 Sea Pro XD	9927000		BP8H-N-10	1	
9.9 HP	9.9C (M) 682	551	32885	B7HS	0.6	BR7HIX	15 (Super 15)	0B238464		BP8H-N-10	1		
	9.9C (ML) 682	300826	338410	B7HS	0.6	BR7HIX	15 (Super 15)	9507381		BP8H-N-10	1		
	9.9C (E) 682	250101	250945	B7HS	0.6	BR7HIX	15 (Super 15)	0A730007		BP8H-N-10	1		
	9.9C (EL) 682	550141	552315	B7HS	0.6	BR7HIX	15 FourStroke, 323cc	0G590000	1B727495	DPR6EA-9	0.9		
	9.9C (M) 682	32886		B7HS-10	1		15 FourStroke, 323cc	9973100		DPR6EA-9	0.9		
	9.9C (ML) 682	338411		B7HS-10	1		15 FourStroke, 351cc	0R235949		DCPR6E	0.8	DCPR6EIX	
	9.9C (E) 682	250946		B7HS-10	1		18 HP	18 (18, 18XD)	5837437		BP8H-N-10	1	
	9.9C (EL) 682	552316		B7HS-10	1			18 (18, 18XD)	8071973		BP8H-N-10	1	
	9.9	0A197112	0G112449	BP8H-N-10	1			18 (18, 18XD)	9308306		BP8H-N-10	1	
	9.9	9461526	9831799	BP8H-N-10	1		20 HP	20A (M, ML) 653	ALL	ALL	B6HS	0.6	BR6HIX
	9.9	0G112450		BP8HS-15	1.5			20C (M, ML, E, EL) 6A9	ALL	ALL	B7HS	0.6	BR7HIX
	9.9	9831800		BP8HS-15	1.5			20 (200)	1290910	1499331	B6S	0.7	
	9.9 FourStroke	0H000058	0H016909	CR6HSA	0.7	CR6HIX		20 (200)	1558310	2094830	B6S	0.7	
	9.9 FourStroke	0G760300	0T979999	DPR6EA-9	0.9			20 (200)	2094831	2827676	B7HS	0.8	BR7HIX
9.9 FourStroke	0P075166	0P325499	DPR6EA-9	0.9		20 (20, 200)		2827677	6443972	BUHW-2	1.8		
9.9 FourStroke	0R042475		DCPR6E	0.8	DCPR6EIX	20 (20, 200)		8006265		BUHW-2	1.8		
9.9 FourStroke	0P325500		DCPR6E	0.8	DCPR6EIX	20 (20, 200)		9016254	9415100	BUHW-2	1.8		
10 HP	10 (100)	1290910	1499331	B6S	0.7			20 (20, 200)	7012358	7209532	BUHW-2	1.8	
	10 (XR10/SEA PRO 10)	0D038000		BP8HS-15	1.5			20 (20, 20XD)	6443973	0T800749	BP8H-N-10	1	
	10 (XR10/SEA PRO 10)	9596000		BP8HS-15	1.5		20 (20, 20XD)	9415101		BP8H-N-10	1		
	10 Magnum/ Marathon	0D038000		BP8HS-15	1.5		20 (20, 20XD)	7209533		BP8H-N-10	1		
	10 Magnum/ Marathon	9596000		BP8HS-15	1.5		20 JET	5705532		BP8H-N-10	1		
	15 HP	15A (M, ML) 651	ALL	ALL	B7HS	0.6	BR7HIX	20 JET	8073158		BP8H-N-10	1	
15C (M) 684		101	20025	B7HS	0.6	BR7HIX	20 JET	9315316		BP8H-N-10	1		
15C (ML) 684		300101	316415	B7HS	0.6	BR7HIX	20 JET	7166928		BP8H-N-10	1		
15C (E) 684		250101	251060	B7HS	0.6	BR7HIX	20 FourStroke (Carb)	0R235168		DCPR6E	0.8	DCPR6EIX	
15C (EL) 684		550101	551615	B7HS	0.6	BR7HIX	25 HP	25A (M, ML, E, EL) 648	ALL	ALL	B7HS	0.6	BR7HIX
15C (M) 684		20026		B7HS-10	1			25C (M, ML, E, EL) 695	ALL	ALL	B7HS	0.6	BR7HIX
15C (ML) 684		316416		B7HS-10	1			W25 (M, ML) 648	ALL	ALL	B7HS	0.6	BR7HIX
15C (E) 684		251061		B7HS-10	1			W25 (M, ML) 695	ALL	ALL	B7HS	0.6	BR7HIX
15C (EL) 684		551616		B7HS-10	1								
W15 662		ALL	ALL	B7HS	0.6	BR7HIX							

MARINER/MERCURY (CONT)

Engine	Model	Serial # Start	Serial # End	Recommended Spark Plug	Gap (mm)	Iridium Option	Engine	Model	Serial # Start	Serial # End	Recommended Spark Plug	Gap (mm)	Iridium Option
25 HP (cont)	W25 (Marathon) (M, ML) 694	ALL	ALL	B7HS	0.6	BR7HIX	40 HP	W40 (Marathon) (M, ML) 6F6	ALL	ALL	B7HS	0.6	BR7HIX
	K25 (M, ML) 6A4	ALL	ALL	B7HS	0.6	BR7HIX		K40 (M, ML) 6F5	ALL	ALL	B7HS	0.6	BR7HIX
	25 (250)	1290910	1499331	B6S	0.7			40 (400)	1279685	1476509	B6S	0.7	
	25 (25, 25XD, 20 JET)	5705532		BP8H-N-10	1			40 (40, 400, 402)	2874704	0G053313	BUHW	1.3	
	25 (25, 25XD, 20 JET)	8073158		BP8H-N-10	1			40 (40, 400, 402)	8002335		BUHW	1.3	
	25 (25, 25XD, 20 JET)	9315316		BP8H-N-10	1			40 (40, 400, 402)	3339688		BUHW	1.3	
	25 (25, 25XD, 20 JET)	7166928		BP8H-N-10	1			40 (40, 400, 402)	3340783		BUHW	1.3	
	25 LIGHTNING (3 cyl)	0E268781		B7HS	0.9	BR7HIX		40 (2 cyl.)	0G053314		BP8H-N-10	1	
	25 FourStroke (Carb)	0G590000	1B344298	DPR6EA-9	0.9			40 (3 cyl.)	0G531301		BP8H-N-10	1	
	25 FourStroke (Carb)	9973100	0P388282	DPR6EA-9	0.9			40 (3 cyl.)	9973100		BP8H-N-10	1	
	25 FourStroke (EFI)	0R106999		DCPR6E	0.8	DCPR6EIX		40 (4 cyl.)	0C159200		BUHW-2	1.8	
	25 FourStroke (EFI)	0P401000		DCPR6E	0.8	DCPR6EIX		40 (4 cyl.)	9570790		BUHW-2	1.8	
	25 Jet, FourStroke	0R165086		DCPR6E	0.8	DCPR6EIX		40 JET	0T178500		BP8H-N-10	1	
	28 HP	28 (M, ML, E, EL) 664	ALL	ALL	B7HS	0.6		BR7HIX	40 JET	0P094500		BP8H-N-10	1
30 HP	30A (M, ML, E, EL) 689	ALL	ALL	B7HS	0.6	BR7HIX	40 (3 cyl. Carb) FourStroke	0G760300	1B226999	DPR6EA-9	0.9		
	W30 (Marathon) (M, ML) 689	ALL	ALL	B7HS	0.6	BR7HIX	40 (3 cyl. Carb) FourStroke	0P094500	0P400999	DPR6EA-9	0.9		
	30 (300)	1271884	1960826	B6S	0.7		40 (3 cyl. EFI) FourStroke	0T409000		DCPR7E	0.9	DCPR7EIX	
	30 (2 cyl.)644cc	0G053314	0T598999	BP8H-N-10	1		40 (3 cyl. EFI) FourStroke	0P153500		DCPR7E	0.9	DCPR7EIX	
	30 (2 cyl.)644cc	9854537	0P206999	BP8H-N-10	1		40 (3 cyl. EFI) FourStroke	1C000001		DCPR7E	0.9	DCPR7EIX	
	30 (Lightning) 430cc	0G575500		B7HS-10	1		40/45 (4 cyl.) FourStroke	0G231123	0T178499	DPR6EA-9	0.9		
	30 JET (4 cylinder)	0C159200	0G589999	BUHW-2	1.8		40 (4 cyl. Carb) FourStroke	0T228405	0T598999	DPR6EA-9	0.9		
	30 JET (4 cylinder)	9570790	9973099	BUHW-2	1.8		40 (4 cyl. Carb) FourStroke	0P094500	0P206999	DPR6EA-9	0.9		
	30 JET (3 cylinder)	0G590000	0T178499	BP8H-N-10	1		40 (4 cyl. Carb) FourStroke	0P094500	0P206999	DPR6EA-9	0.9		
	30 JET (3 cylinder)	9973100	0P094499	BP8H-N-10	1		40 (4 cyl. EFI) FourStroke	0T409000		DCPR7E	0.9	DCPR7EIX	
	30 (Carb) FourStroke	0G760300	1B226999	DPR6EA-9	0.9		40 (4 cyl. EFI) FourStroke	0P207000		DCPR7E	0.9	DCPR7EIX	
	30 (Carb) FourStroke	0P094500	0P400999	DPR6EA-9	0.9		40 (4 cyl. EFI) FourStroke	1C000001		DCPR7E	0.9	DCPR7EIX	
	30 (EFI) FourStroke	0T409000	1B226999	DCPR7E	0.9	DCPR7EIX	40 JET (4 cyl. EFI) FourStroke	1C051324		DCPR7E	0.9	DCPR7EIX	
	30 (EFI) FourStroke	0R106999		DCPR6E	0.8	DCPR6EIX	45 HP	45 (450)	1476510	1531568	B6S	0.7	
35 HP	35 (350, 35A)	1271884	1960826	B6S	0.7			45 (4 cyl.)	5531630		BUHW-2	1.8	
	35 (350)	1960827	2097831	B7S	0.7			45 (4 cyl.)	8063985		BUHW-2	1.8	
	35 (350)	2097832	2874703	B7HS	0.8	BR7HIX		45 (4 cyl.)	9248006		BUHW-2	1.8	
	35	6445653		BUHW	1.3			45 (4 cyl.)	7143688		BUHW-2	1.8	
	35	9384476		BUHW	1.3		45 JET	0G760300	0T129554	BP8H-N-10	1		
	35	7209608		BUHW	1.3		45 JET	0P017000	0P094499	BP8H-N-10	1		
40 HP	40A (M, ML, E, EL) 676	ALL	ALL	B8HS	0.6	BR8HIX	48 HP	48 (M, ML) 670	ALL	ALL	B7HS	0.6	BR7HIX
	40B (M, ML, E, EL) 676	ALL	ALL	B8HS	0.6	BR8HIX	W48 (M,ML) 670 A	ALL	ALL	B7HS	0.6	BR7HIX	
	40C (M, ML, E, EL) 6000000000	ALL	ALL	B8HS	0.6	BR8HIX	50 HP	50 (500)	1421113	2097444	B6S	0.7	
	W40 (M, ML) 676	ALL	ALL	B8HS	0.6	BR8HIX		50 (500)	1770179	2116317	B6S	0.7	
								50 (500)	2097445	4357639	BUHW	1.3	
						50 (500)		2863739	8029514	BUHW	1.3		
						50 (500)		9001581	9107213	BUHW	1.3		
						50 (500)		2116318	7068997	BUHW	1.3		
						50 (50, 500)(4 cyl.)	4357640		BUHW-2	1.8			



MARINE – OUTBOARD RANGE

MARINER/MERCURY (CONT)

Engine	Model	Serial # Start	Serial # End	Recommended Spark Plug	Gap (mm)	Iridium Option	Engine	Model	Serial # Start	Serial # End	Recommended Spark Plug	Gap (mm)	Iridium Option	
50 HP (cont)	50 (50, 500)(4 cyl.)	8030090		BUHW-2	1.8		65 HP	65 (650)(3 cyl.)	8006640		BUHW	1.3		
	50 (50, 500)(4 cyl.)	9107214		BUHW-2	1.8			65 (650)(3 cyl.)	9020074	9135824	BUHW	1.3		
	50 (50, 500)(4 cyl.)	7068998		BUHW-2	1.8			65 (650)(3 cyl.)	7013633	7087822	BUHW	1.3		
	50 (3 cyl.)	6428681	0D000749	BUHW	1.3			65 JET	0D283222		BUHW-2	1.8		
	50 (3 cyl.)	9385911	9683054	BUHW	1.3			65 JET	9793577		BUHW-2	1.8		
	50 (3 cyl.)	7208333		BUHW	1.3			70 HP	70 (700)	1296411	1566239	B6S	0.7	
	50 (3 cyl.)	0D000750		BP8H-N-10	1				70 (3 cyl.)	4571652	6428680	BUHW	1.3	
	50 (3 cyl.)	9683055		BP8H-N-10	1				70 (3 cyl.)	8042350		BUHW	1.3	
	50 FourStroke	0G231123	0T178499	DPR6EA-9	0.9				70 (3 cyl.)	9135825	9385910	BUHW	1.3	
	50 (Carb) FourStroke	0T178500	0T598999	DPR6EA-9	0.9				70 (3 cyl.)	7087823	7208332	BUHW	1.3	
	50 (Carb) FourStroke	0P094500	0P206999	DPR6EA-9	0.9				70 (3 cyl.)	0A996142	0C221999	BUHW-2	1.8	
	50 (EFI) FourStroke	0T409000		DCPR7E	0.9	DCPR7EIX			70 (3 cyl.)	9483121	9589038	BUHW-2	1.8	
	50 (EFI) FourStroke	0P207000		DCPR7E	0.9	DCPR7EIX		75 HP	75 (4 cyl.)	6432907		BUHW-2	1.8	
50 (EFI) FourStroke	1C000001		DCPR7E	0.9	DCPR7EIX	75 (4 cyl.)	9393856			BUHW-2	1.8			
55 HP	55 (M, ML) 663	ALL	ALL	B8HS	0.6	BR8HIX	75 (4 cyl.)		7208573		BUHW-2	1.8		
	55 (E) 663	0	4040	B8HS	0.6	BR8HIX	75 (3 cyl.)		0C222000		BUHW-2	1.8		
	55 (EL) 663	0	315378	B8HS	0.6	BR8HIX	75 (3 cyl.)		9589039		BUHW-2	1.8		
	55 (E) 663	4041		B8HS-10	1		75 (3 cyl.)(1.5L Optimax)		0T980000		IZFR5J	0.8		
	55 (EL) 663	315379		B8HS-10	1		75 FourStroke, 1596cc		0G960500	1B366822	LFR5A-11	1.1	LFR5AIX-11	
	W55 (ML) 663	ALL	ALL	B7HS	0.6	BR7HIX	75 FourStroke	1B366823		LFR4A-E	0.8			
	55 (3 cyl.)	0D000750		BP8H-N-10	1		80 HP	80 (800)(6 cyl.)	1335465	1566239	B7S	0.7		
	55 (3 cyl.)	9741042		BP8H-N-10	1			80 (800)(4 cyl.)	2559001	3493912	BUHW	1.3		
60 HP	60 (E) 675	101	780	B8HS	0.6	BR8HIX		80 (80, 800)(4 cyl.)	4831999	6432900	BUHW-2	1.8		
	60 (EL) 675	300101	302050	B8HS	0.6	BR8HIX		80 (80, 800)(4 cyl.)	8050200		BUHW-2	1.8		
	60 (E) 675	781		B8HS-10	1			80 (80, 800)(4 cyl.)	9177626	9393855	BUHW-2	1.8		
	60 (EL) 675	302051		B8HS-10	1			80 (80, 800)(4 cyl.)	7110998	7208572	BUHW-2	1.8		
	60 (E, EL) 6FO	ALL	ALL	B8HS-10	1			80 (3 cyl.)	0A996142	0C221999	BUHW-2	1.8		
	60 (600)	1303411	1542744	B6S	0.7			80 (3 cyl.)	9483121	9589038	BUHW-2	1.8		
	60 (3 cyl.)	6428681	0D000749	BUHW	1.3			80 JET	0D283222		BP8H-N-10	1		
	60 (3 cyl.)	9385911	9683054	BUHW	1.3			80 JET	9793577		BP8H-N-10	1		
	60 (3 cyl.)	7208333		BUHW	1.3		80 FourStroke	1B366823		LFR4A-E	0.8			
	60 (3 cyl.)	0D000750		BP8H-N-10	1		80 FourStroke	0P401000		LFR4A-E	0.8			
	60 (3 cyl.)	9683055		BP8H-N-10	1		85 HP	85 (850)(6 cyl.)	1460999	1766823	B7S	0.7		
	60 (Carb) FourStroke	0T178500	0T598999	DPR6EA-9	0.9			85 (850)(4 cyl.)	3493913	4831998	BUHW	1.3		
	60 (Carb) FourStroke	0P094500	0P206999	DPR6EA-9	0.9			85 (850)(4 cyl.)	8005440	8050199	BUHW	1.3		
60 (EFI) FourStroke	0T409000		DCPR7E	0.9	DCPR7EIX	85 (850)(4 cyl.)		9011604	9177625	BUHW	1.3			
60 (EFI) FourStroke	0P207000		DCPR7E	0.9	DCPR7EIX	85 (850)(4 cyl.)		7010108	7110997	BUHW	1.3			
60 (EFI) FourStroke	1C000001		DCPR7E	0.9	DCPR7EIX	90 HP	90 (900)	1766824	1869775	B7S	0.7			
65 HP	65 (650)(4 cyl.)	1542745	2119748	B7S	0.7			90 (90, 900)(6 cyl.)	4845301		BUHW	1.3		
	65 (650S)(4 cyl.)	2119749	2309310	B7HS	0.8		BR7HIX	90 (90, 900)(6 cyl.)	8060545		BUHW	1.3		
	65 (650SS)(4 cyl.)	2119749	2309310	BUHW	1.3			90 (90, 900)(6 cyl.)	7111698		BUHW	1.3		
	65 (650)(3 cyl.)	3293184	4571651	BUHW	1.3			90 (3 cyl.)	0A996142		BUHW-2	1.8		
							90 (3 cyl.)	9483121		BUHW-2	1.8			
							90 (3 cyl.) (1.5L Optimax)	0T801000		IZFR5J	0.8			
							90 FourStroke, 1596cc	0G960500	1B366822	LFR5A-11	1.1	LFR5AIX-11		

MARINER/MERCURY (CONT)

Engine	Model	Serial # Start	Serial # End	Recommended Spark Plug	Gap (mm)	Iridium Option	Engine	Model	Serial # Start	Serial # End	Recommended Spark Plug	Gap (mm)	Iridium Option
90 HP (cont)	90 FourStroke	1B366823		LFR4A-E	0.8		150 HP	V-150 ProXS	1B690542		IZFR6J	0.8	
95 HP	95 (950)	1869776	1962186	B7HS	0.8	BR7HIX	150 EFI FourStroke	1B905505			ZFR5F	0.8	
	95 (950)	1962187	2318585	BUHW	1.3		150 Verado	1B227000			ILFR6G-E	0.8	
100 HP	100 (1000)	1464949	2318585	B7S	0.7		150 Verado	0P419487			ILFR6G-E	0.8	
	100 (1000SS/1000BP)	2318586	3253111	BUHW	1.3		175 HP	V-175 (175, 1750) Carb	4301235	0G960499	BU8H	1.55	
	100 (4 cyl.)	0B209468	0G960499	BP8H-N-10	1		V-175 (175, 1750) Carb	8058870			BU8H	1.55	
	100 (4 cyl.)	9523034	0P058999	BP8H-N-10	1		V-175 EFI	0D000750	0G960499		BU8H	1.55	
	100 FourStroke	1B366823		LFR4A-E	0.8		V-175 EFI	0G960500	0T800999		BPZ8HS-10	1	
	100 FourStroke	0P401000		LFR4A-E	0.8		V-175 DFI	0T178500			IZFR5G	0.8	
							V-175 Pro XS	1B516339			IZFR6J	0.8	
110 HP	110 (1100)	1870204	1962661	B7HS	0.8	BR7HIX	175 Verado	1B227000			ILFR6G-E	0.8	
	110 (1100)	1962662	2314955	BUHW	1.3		175 Verado	0P464488			ILFR6G-E	0.8	
115 HP	115 (115, 1150) (6 cyl.)	2836019		BUHW	1.3		200 HP	V-200 (200, 2000) Carb	4839034	0G960499	BU8H	1.55	
	115 (115, 1150) (6 cyl.)	8008665		BUHW	1.3		V-200 (200, 2000) Carb	8061595	8065672		BU8H	1.55	
	115 (115, 1150) (6 cyl.)	7010763		BUHW	1.3		V-200 (200, 2000) Carb	0G960500			BPZ8HS-10	1	
	115 (4 cyl.)	0C100000		BP8H-N-10	1		V-200 EFI	0C100861	0C291520		BUZ8H	1.55	
	115 (4 cyl.)	9559771		BP8H-N-10	1		V-200 EFI	0C291521	0G960499		BU8H	1.55	
	115 (3 cyl.)(1.5L Optimax)	0T801000		IZFR5J	0.8		V-200 EFI (2.5L)	0G960500			BPZ8HS-10	1	
	115 Pro XS	1B751825		IZFR5J	0.8		V-200 EFI (3.0L)	0T750164			BR8HS	1	BR8HIX
	115 (EFI) FourStroke, 1741cc	0T178500	1B366822	LFR6A-11	1	LFR6AIX-11	V-200 DFI	0G386496			IZFR5G	0.8	
	115 (EFI) FourStroke	1B366823		LFR4A-E	0.8		V-200 Pro XS	1B504989			IZFR5G	0.8	
125 HP	125 (1250)(6 cyl.)	2314956	3253111	BUHW	1.3		200 Verado, 4&6 cylinder	0T980000			ILFR6G-E	0.8	
	125 (4 cyl.)	0D283222		BP8H-N-10	1		200 Verado, 4&6 cylinder	0P409357			ILFR6G-E	0.8	
	125 (4 cyl.)	9793577		BP8H-N-10	1		220 HP	V-220 Laser	0B117316		BUZ8H	1.55	
135 HP	135 (1350)(6 cyl.)	2839369	3293233	BUHW	1.3		225 HP	V-225 (2.4L)	5628028		BU8H	1.55	
	V-135	0A904646		BU8H	1.55		V-225 (3.0L)Carb	0D280813	0G437999		BPZ8H-N-10	1	
	V-135 DFI	0G590000		IZFR5G	0.8		V-225 (3.0L)Carb	0G438000			BR8HS	0.9	BR8HIX
	135 Verado	1B227000		ILFR6G-E	0.8		V-225 Sea Pro & Marathon	0G245605			BR8HS	0.9	BR8HIX
	135 Verado	0P419487		ILFR6G-E	0.8		V-225 EFI(3.0L)	0G129222			BR8HS	0.9	BR8HIX
140 HP	140 (140, 1400) (6 cyl.)	3293234		BUHW	1.3		V-225 DFI	0G590000			IZFR5G	0.8	
	140 (140, 1400) (6 cyl.)	8052650		BUHW	1.3		V-225 DFI (DTS)	0G599000			IZFR5G	0.8	
	140 (140, 1400) (6 cyl.)	7112773		BUHW	1.3		V-225 Pro XS	1B104549			IZFR6J	0.8	
150 HP	150 (1500)(6 cyl.)	3502806	4865677	BUHW	1.3		225 (EFI) FourStroke	0T653945			LFR5A-11	1.1	LFR5AIX-11
	150 (1500)(6 cyl.)	8005615	8052649	BUHW	1.3		225 Verado	0T980000			ILFR6G-E	0.8	
	150 (1500)(6 cyl.)	7010533	7112772	BUHW	1.3		225 Verado	0P409357			ILFR6G-E	0.8	
	V-150 (150, 1500) Carb	4868998	0G960499	BU8H	1.55		250 HP	V-250 (3.4L)	0C101891		BU8H	1.55	
	V-150 (150, 1500) Carb	0G960500		BPZ8HS-10	1		V-250 EFI (3.0L)	0G129222			BR8HS	0.9	BR8HIX
	V-150 EFI	0D082000	0G960499	BU8H	1.55		V-250 DFI (3.0L)	1B528615			IZFR6J	0.8	
	V-150 EFI	0G960500		BPZ8HS-10	1		V-250 Pro XS	1B426561			IZFR6J	0.8	
	V-150 (XR2/4/6/ Magnum II/III)	4868998	0G960499	BU8H	1.55		250 Verado	0T980000			ILFR6G-E	0.8	
	V-150 (XR2/4/6/ Magnum II/III)	0G960500		BPZ8HS-10	1		250 Verado	0P409357			ILFR6G-E	0.8	
	V-150 DFI	0G590000		IZFR5G	0.8		275 HP	V-275 (3.4L)	0C101891		BU8H	1.55	
						275 Verado	0T980000			ILFR6G-E	0.8		
						275 Verado	0P409357			ILFR6G-E	0.8		



MARINE – OUTBOARD RANGE

MARINER/MERCURY (CONT)

Engine	Model	Serial # Start	Serial # End	Recommended Spark Plug	Gap (mm)	Iridium Option
300 HP	V-300 (3.4L)	5611648		BU8H	1.55	
	300 Verado	0T980000		ILFR6G-E	0.8	
	300 Verado	0P520553		ILFR6G-E	0.8	
350 HP	350 Verado	1B718256		ILFR6G-E	0.8	
Racing Engines						
25SS	21.9 cu.in.			BUHW	1.3	
650X	49 cu.in.			BUHW	1.3	
Twister 11-X	99 cu.in.			BUHW	1.3	

Make & Model	Other	Year	Recommended Part No.	Gap (mm)	Iridium Option
--------------	-------	------	----------------------	----------	----------------

MEDINA

ALL MODELS			B6HS	0.8	BR6HIX
------------	--	--	------	-----	--------

MCCULLOCH

3.5HP		1964-69	B-6L	0.8	
4.0HP	Long Shaft	1964-69	B-6L	0.8	
7.5HP		1964-69	B-6L	0.8	
9.0HP			BM6A	0.9	
9.5HP			B6S	0.8	
9.9HP			BM6A	0.8	
14HP			B6S	0.8	
28HP	Manual Start		B6S	0.8	
45HP	Electric Start		B6S	0.8	
	Manual Start		B6S	0.8	
75HP			B6S	0.8	
590/630			B6S	0.8	

OMC

See Evinrude					
--------------	--	--	--	--	--

PARSUN

2.5HP	2 Stroke		BPR7HS	0.7	BPR7HIX
2.6HP	4 Stroke		BPR7HS	0.7	BPR7HIX
3.6HP	2 Stroke		BPR7HS	0.7	BPR7HIX
4.0HP	4 Stroke		BPR7HS	0.7	BPR7HIX
5.0HP	4 Stroke		BPR7HS	0.7	BPR7HIX
9.9HP	2 Stroke		BPR7HS	0.7	BPR7HIX
15.0HP	2 Stroke		BPR7HS	0.7	BPR7HIX
	4 Stroke		DPR7EA-9	0.7	DPR7EIX-9
25.0HP	4 Stroke		DPR7EA-9	0.7	DPR7EIX-9
30.0HP	2 Stroke		BPR7HS	0.7	BPR7HIX
40.0HP	2 Stroke		BPR7HS	0.7	BPR7HIX

PERKINS

4.5HP		1962-65	B6S	0.7	
6HP		1959-61	B6S	0.7	
6.5HP		1962-65	B6S	0.7	
16HP		1959-61	B-6L	0.7	

Make & Model	Other	Year	Recommended Part No.	Gap (mm)	Iridium Option
18HP		1962-65	B-6L	0.7	
30HP		1962-65	B6HS	0.7	BR6HIX
35HP	(18mm Head)	1959-60	AB-6	0.9	
	(14mm Head)	1961	B6HS	0.7	BR6HIX
40HP		1959-61	B6HS	0.7	BR6HIX
		1962-65	B6HS	0.7	BR6HIX

SELVA-SELVA GEMINI

3.0HP Selva Gemini			B6S	0.5	
4.5HP Selva Gemini			B6S	0.5	
5.0HP S115, S115SI			BPR6HS	0.5	BPR6HIX
6.0HP S135, S135SI, S155			BPR6HS	0.5	BPR6HIX
6.0HP Selva Gemini			B6S	0.5	
8.0HP S165			BPR6HS	0.5	BPR6HIX
9.9HP S175			BPR6HS	0.5	BPR6HIX
15HP S260			BPR6HS	0.5	BPR6HIX
20HP S405			BPR6HS	0.5	BPR6HIX
25HP S495			BPR6HS	0.5	BPR6HIX
25HP S500 Grand Prix, S600 Master			B7HS-10	1.0	
25HP S600 Best, S1050 Super Best			B7HS-10	1.0	
30HP S505			B7HS-10	1.0	
35HP S525			B7HS-10	1.0	
40HP S625			B7HS-10	1.0	
50HP S700			B7HS-10	1.0	
55HP S750			B7HS-10	1.0	
65HP S850			B7HS-10	1.0	
74.5HP S1300 Endurance			B7HS-10	1.0	
80HP S1000			B7HS-10	1.0	
90HP S1350			B7HS-10	1.0	
100HP S1400			B7HS-10	1.0	

SPIRIT

2.0HP Spirit 2		1977-81	BR5HS	0.6	
3.5HP Spirit 3.5		1979-81	BPR6HS	0.8	BPR6HIX
4.5HP Spirit 4.5		1976-77	BR6HS	0.7	
5.0HP Spirit 5		1978-81	BPR6HS	0.7	BPR6HIX
7.5HP Spirit 7.5			BR6HS	0.7	
8.0HP Spirit 8		1980-81	BPR6HS	0.7	BPR6HIX
9.9HP Spirit 9.9		1976-80	BR6HS	0.7	
16HP Spirit 16		1976-81	BR7HS	0.7	BR7HIX
20HP Spirit 20		1976-78	BR7HS	1.0	BR7HIX
		1979-81	BR7HS	1.0	BR7HIX
25HP Spirit 25		1976-81	BR7HS	1.0	BR7HIX
40HP Spirit 40		1980-81	BR8HS	1.0	BR8HIX
50HP Spirit 50		1977-81	BR8HS	1.0	BR8HIX
65HP Spirit 65		1977-81	BR8HS	1.0	BR8HIX
85HP Spirit 85		1979-81	BR8HS	1.0	BR8HIX

Make & Model	Other	Year	Recommended Part No.	Gap (mm)	Iridium Option
SUZUKI					
DT2		to 1990	BR4HS	0.7	
		1991-99	BR5HS	0.7	
DT2.2		1997	BR5HS	0.7	
DT3.5		to 1994	BP6HS	0.7	BPR6HIX
DT4		1988-92	BP5HS	0.7	
		1993-01	BPR5HS	0.7	
DT4.5			B6HS	0.6	BR6HIX
DF4	(4-Stroke)	2002 on	BPR6ES	0.8	BPR6EIX
DT5		to 1994	BP6HS	0.7	BPR6HIX
DT5Y		1999 on	BPR7HS-10	1.0	BPR7HIX
DT5W			BP6HS	0.7	BPR6HIX
DF5	(4-Stroke)	2002 on	BPR6ES	0.8	BPR6EIX
DT6		to 1985	BP6HS	0.7	BPR6HIX
		1986 on	BR6HS-10	1.0	
	(4-Stroke)	2002 on	BPR6ES	0.8	BPR6EIX
DT8			BP6HS	0.7	BPR6HIX
DT8C		to 1997	BR6HS-10	1.0	
DT9		1978-79	B6HS	0.6	BR6HIX
DT9.9		1977-82	BR7HS-10	1.0	BR7HIX
		1983-85	B7HS-10	1.0	
		1986-88	BR6HS-10	1.0	
	(4Stroke)	1997 on	DCPR6E	0.8	DCPR6EIX
DT9.9C		to 1997	BR6HS-10	1.0	
DT9.9E		1982	B6HS	0.7	BR6HIX
		1983	BR7HS-10	1.0	BR7HIX
		1984	B7HS	0.7	BR7HIX
DT9.9K		to 1985	BR6HS	0.7	
		1986-95	B6HS	0.7	BR6HIX
DT9.9P		to 1983	B6HS	0.7	BR6HIX
DT15		1983 on	B7HS-10	1.0	
		1996 on	DCPR6E	0.8	DCPR6EIX
DT15C		to 1995	BR7HS	0.7	BR7HIX
DT15K		to 1985	BR6HS	0.7	
		1986 on	B6HS	0.7	BR6HIX
DT16, DT16P			B7HS	0.7	BR7HIX
DT20, DT20P		to 1985	B7HS	0.7	BR7HIX
DT20		1995-96	BR7HS-10	1.0	BR7HIX
DT20K		to 1985	BR7HS-10	1.0	BR7HIX
		1986-87	B7HS-10	1.0	
DF25	(4-Stroke)	2000 on	DCPR6E	0.8	DCPR6EIX
DT25		to 1985	BR7HS	0.6	BR7HIX
		1986 on	BR7HS-10	1.0	BR7HIX
DT25C		1996 on	BR7HS-10	1.0	BR7HIX
DT25E		to 1982	B7HS	0.7	BR7HIX
		1983-85	BPR7HS-10	1.0	BPR7HIX
		1986 on	BR7HS-10	1.0	BR7HIX
DT25K			B7HS-10	1.0	

Make & Model	Other	Year	Recommended Part No.	Gap (mm)	Iridium Option
DT25P			B7HS	0.7	BR7HIX
DT28, DT28E, DT28P		to 1983	B7HS	0.7	BR7HIX
DF30	(4-Stroke)	2000 on	DCPR6E	0.8	DCPR6EIX
DT30		1983-85	BR7HS-10	1.0	BR7HIX
		1986 on	BR7HS-10	1.0	BR7HIX
DT30C		1996-97	BR7HS-10	1.0	BR7HIX
DT30E (R)		1983 on	BR7HS-10	1.0	BR7HIX
DF40		1999-02	DCPR6E	0.8	DCPR6EIX
DT40		to 1983	B8HS	0.9	BR8HIX
DT40C, DT40CR, DT40TC		1994-98	BR8HS-10	1.0	BR8HIX
DT40K, DT40KR			B7HS-10	1.0	
DT40W		to 1993	B8HS	0.9	BR8HIX
		1994-96	B8HS-10	1.0	
DT40WK			B7HS-10	1.0	
DT48M		to 2000	B8HS	0.9	BR8HIX
		2001 on	B8HS-10	1.0	
DF50	(4-Stroke)	1999 on	DCPR6E	0.8	DCPR6EIX
DT50		to 1990	B8HS-10	1.0	
	ACR	1994-95	BR8HS-10	1.0	BR8HIX
DT50C		1984-00	B8HS-10	1.0	
		2001 on	BR8HS-10	1.0	BR8HIX
DT50K			B7HS	0.7	BR7HIX
DT50M, DT50(W), DT50T		to 1985	B8HS	0.9	BR8HIX
DT50M, DT50(W)		1986-89	B8HS-10	1.0	
		2001 on	BR8HS-10	1.0	BR8HIX
DT55C, DT55M, DT55MQ			BR8HS-10	1.0	BR8HIX
DT55TC, DT55CRQ			BR8HS-10	1.0	BR8HIX
DF60	(4-Stroke)	1998 on	BPR6ES	0.8	BPR6EIX
DT60, DT60W			B8HS-10	1.0	
DT60C		1986-87	B8HS-10	1.0	
		2001 on	BR8HS-10	1.0	BR8HIX
DT65, DT65T		to 1983	B8HS	0.9	BR8HIX
DT65C		to 1992	B8HS	0.9	BR8HIX
		1993 on	BR8HS	0.9	BR8HIX
DT65TC		1993-98	BR8HS	0.9	BR8HIX
		1998 on	BR8HS-10	1.0	BR8HIX
DF70	(4-Stroke)	1998 on	BPR6ES	0.8	BPR6EIX
DT75, DT75C, DT75M		to 2000	B8HS	0.9	BR8HIX
		2001 on	BR8HS-10	1.0	BR8HIX
DT75TC		to 2000	B8HS	0.9	BR8HIX
		2001 on	BR8HS-10	1.0	BR8HIX
DT85, DT85C		to 1992	B8HS	0.9	BR8HIX
DT85C		1993-00	BR8HS	0.9	BR8HIX
		2001 on	BR8HS-10	1.0	BR8HIX
DT85M, DT86Q		to 2000	B8HS	0.9	BR8HIX
		2001 on	BR8HS-10	1.0	BR8HIX
DT85MQ		1995-96	B8HS-10	1.0	



MARINE – OUTBOARD RANGE

Make & Model	Other	Year	Recommended Part No.	Gap (mm)	Iridium Option
SUZUKI (CONT)					
DT85TC		to 2000	B8HS	0.9	BR8HIX
		2001 on	BR8HS-10	1.0	BR8HIX
DT85W/WT		2001 on	B8HS-10	1.0	
DT85W		to 2000	BR8HS	0.9	BR8HIX
DT85WT		1995-96	B8HS-10	1.0	
DF90	(4-Stroke)	2001 on	BKR6E	0.9	BKR6EIX
DT90		to 2000	BR8HCS-10	1.0	
		2001 on	BR8HS-10	1.0	BR8HIX
DT90TC		to 1995	BR8HCS-10	1.0	
		1996-97	B8HS	0.9	BR8HIX
		1998 on	BR8HS-10	1.0	BR8HIX
DT100TC		to 1995	BR8HCS-10	1.0	
DT100		to 2000	BR8HCS-10	1.0	
		2001 on	BR8HS-10	1.0	BR8HIX
DF115		2001 on	BKR6E	0.9	BKR6EIX
DT115, DT115C		to 1990	B8HS-10	1.0	
		1991 on	BR8HCS-10	1.0	
DT115STC	EFI	1996-01	BR8HS-10	1.0	BR8HIX
DF140	(4-Stroke)	2002 on	BKR6E	0.9	BKR6EIX
DT140, DT140C		to 1990	B8HS-10	1.0	
		1991-96	BR8HCS-10	1.0	
		2001 on	BR8HS-10	1.0	BR8HIX
DT140T		to 2000	BR8HCS-10	1.0	
		2001 on	BR8HS-10	1.0	BR8HIX
DT140TC		1991-96	BR8HCS-10	1.0	
	EFI	1997 on	BR8HS-10	1.0	BR8HIX
DT150, DT150G			BR8HS-10	1.0	BR8HIX
DT150SS, DT150STC			BR8HS-10	1.0	BR8HIX
DT150	EFI V6	1995 on	BR8HS-10	1.0	BR8HIX
DT150S	EFI V6	1993 on	BR8HS-10	1.0	BR8HIX
DT175		to 1992	BR8HS-10	1.0	BR8HIX
DT200, DT200G			BR8HS-10	1.0	BR8HIX
DT200T, DT200TC, DT200V			BR8HS-10	1.0	BR8HIX
DT200	EFI V6	1994 on	BR8HS-10	1.0	BR8HIX
DF200	(4-Stroke)	2004 on	BKR6E	0.8	BKR6EIX
DT225		1990 on	BR8HS-10	1.0	BR8HIX
DF225	(4-Stroke)	2004 on	BKR6E	0.8	BKR6EIX
DF250	(4-Stroke)	2004 on	BKR6E	0.8	BKR6EIX
PU40		1989-93	B8HS	0.9	BR8HIX
		1994-95	BR8HS-10	1.0	BR8HIX
PU55		1989-93	B8HS	0.9	BR8HIX
		1994-95	BR8HS-10	1.0	BR8HIX
PU85		1989-95	B8HS	0.9	BR8HIX
		1996-97	BR8HS-10	1.0	BR8HIX
PU140		1991-95	BR8HCS-10	1.0	
		1996-97	BR8HS-10	1.0	BR8HIX

Make & Model	Other	Year	Recommended Part No.	Gap (mm)	Iridium Option
TANAKA					
Aqua Bug			BM6A	0.6	
Super Bug			BM6A	0.6	
TOB-12			BM6A	0.6	
TOB-25		1986 on	BMR6A	0.6	
		to 1985	BM6A	0.6	
TOB-120, TOB-175, TOB-300			BMR6A	0.6	
TOB-550			BPR7HS	0.7	BPR7HIX
Bumble Bee			BM6F	0.6	
VALMET OY					
Vire 7			B-4H	0.5	
TOHATSU					
M2.5A/A2			BPR6HS-10	1.0	BPR6HIX
M3.5A/A2			BPR6HS-10	1.0	BPR6HIX
M3.5B/B2			BPR6HS-10	1.0	BPR6HIX
M4C			BPR7HS-10	1.0	BPR7HIX
M5B/BS			BPR7HS-10	1.0	BPR7HIX
M6B			BPR7HS-10	1.0	BPR7HIX
M8B			BPR7HS-10	1.0	BPR7HIX
M9.8B			BPR7HS-10	1.0	BPR7HIX
M9.9B/B2/C/D/D2			BR7HS-10	1.0	BR7HIX
M15B/B2/C/D/D2			BR7HS-10	1.0	BR7HIX
M18C/C2/C/E/E2			BR7HS-10	1.0	BR7HIX
M25C/C2/C3			BR7HS-10	1.0	BR7HIX
M30A3			BR7HS-10	1.0	BR7HIX
M30A4			BR7HS-10	1.0	BR7HIX
M30AK			B7HS	0.7	BR7HIX
M35B			BR7HS-10	1.0	BR7HIX
M35C			BR7HS-10	1.0	BR7HIX
M40C			BR7HS-10	1.0	BR7HIX
M40D/D2			BR7HS-10	1.0	BR7HIX
MD40 TLDI			PZFR6H	0.8	
M45A/A2			BR8HS-10	1.0	BR8HIX
M50C			BR8HS-10	1.0	BR8HIX
M50D/D2			BR8HS-10	1.0	BR8HIX
MD50A TLDI			ZFR6F-11	1.0	ZFR6FIX-11
MD50B TLDI			PZFR6H	0.8	
M55A			BR8HS-10	1.0	BR8HIX
M55B			BR8HS-10	1.0	BR8HIX
M60A			BR8HS-10	1.0	BR8HIX
M60B			BR8HS-10	1.0	BR8HIX
M60C			BR8HS-10	1.0	BR8HIX
M70A/A2			BR8HS-10	1.0	BR8HIX
M70A/A2 TLDI			ZFR6F-11	1.0	ZFR6FIX-11
M70B			BR8HS-10	1.0	BR8HIX
M70C			BR8HS-10	1.0	BR8HIX
MD70B TLDI			PZFR6H	0.8	
MD70B TLDI #033166XD on			IZFR5J	0.8	

Make & Model	Other	Year	Recommended Part No.	Gap (mm)	Iridium Option
TOHATSU (CONT)					
M80A			BR8HS-10	1.0	BR8HIX
M90A			BR8HS-10	1.0	BR8HIX
M90A/A2 TLDI			ZFR6F-11	1.0	ZFR6FIX-11
MD90B TLDI			PZFR6H	0.8	
MD90B TLDI #033166XD on			IZFR5J	0.8	
M120A/A2			BR8HS-10	1.0	BR8HIX
M140A/A2			BR8HS-10	1.0	BR8HIX
MFS4A2/5A2/6A2			DCPR6E	0.8	DCPR6EIX
MFS9.9A/15A			DCPR6E	0.8	DCPR6EIX
MFS9.9B/15B			DCPR6E	0.8	DCPR6EIX
VOLVO-PENTA					
U22		to 1974	B6HS	0.5	BR6HIX
35		to 1974	B6HS	0.5	BR6HIX
39		1973-79	B6HS	0.5	BR6HIX
40, 50, 50A		to 1974	B6HS	0.5	BR6HIX
51		1975-78	B6HS	0.5	BR6HIX
60		1978-79	B6HS	0.5	BR6HIX
80		1971-74	B5HS	0.5	
		1978-79	B5HS	0.5	
90		1971-79	B5HS	0.5	
120		to 1974	B5HS	0.5	
140		1972-79	B5HS	0.5	
200		1975-79	BUHX	0.75	
250		1975	BUHX	0.75	
252		to 1974	BP7HS	0.5	BPR7HIX
350		1975-76	B8HS	0.5	BR8HIX
360		1971-74	B6HS	0.5	BR6HIX
450		1971-74	B8HS	0.5	BR8HIX
		1975-76	BUHX	0.75	
550X		to 1974	B8HS	0.5	BR8HIX
600		1973-76	BUHX	0.75	
700		1973-77	BUHX	0.75	
VOYAGER					
3.5HP		1961	B6S	0.8	
1VA, 1VB, 2VA			AB-6	0.8	
V2L, V2LL, V2N			AB-6	0.8	
V3LGS, V3LLGS, V3NGS			B6S	0.8	
V4GS			AB-6	0.8	
V4LLGS, V4NGS			B6S	0.8	
V6LLGS, V6NGS			B6S	0.8	
YAMAHA					
2 HP 2B	1 Cyl, 43 cc, 2 Stroke	1984 - 2005	B5HS	0.7	
2 HP 2C	1 Cyl, 1Carb, 50 cc, 2 Stroke	01/1984 - on	B7HS	0.7	BR7HIX
2.5 HP F2.5A	1 Cyl, 1Carb, 72 cc, 4 Stroke	01/2003 - on	BR6HS	0.7	

Make & Model	Other	Year	Recommended Part No.	Gap (mm)	Iridium Option
3 HP 3A	1 Cyl, 1Carb, 70 cc, 2 Stroke	01/1988 - on	B6HS-10	1.0	
4 HP 4AC	1 Cyl, 1Carb, 83 cc, 2 Stroke	01/2003 - on	B7HS	0.7	BR7HIX
4 HP 4BC	103 cc, 2 Stroke	1984 - on	B7HS	0.7	BR7HIX
4 HP F4A	1 Cyl, 1Carb, 112 cc, 4 Stroke	01/2003 - on	BR6HS	0.7	
4 HP F4B	1 Cyl, 1Carb, 139 cc, 4 Stroke	02/2010 - on	CR6HSB	0.7	CR6HIX
5 HP 5C	1 Cyl, 1Carb, 2 Stroke	01/2003 - on	B7HS	0.7	BR7HIX
5 HP 5CS	1 Cyl, 1Carb, 2 Stroke	2013 - on	B7HS	0.7	BR7HIX
5 HP F5A	1 Cyl, 1Carb, 139 cc, 4 Stroke	02/2010 - on	CR6HSB	0.7	CR6HIX
6 HP 6C	2 Cyl, 1Carb, 165 cc, 2 Stroke	01/1986 - on	B7HS-10	1.0	
6 HP 6D	165 cc, 2 Stroke	1986 - 2007	B6HS-10	1.0	
6 HP F6A	197 cc, 4 Stroke	2000 - 2010	BR6HS-10	1.0	
6 HP F6B	197 cc, 4 Stroke	2000 - 2006	BR6HS-10	1.0	
6 HP F6C	1 Cyl, 1Carb, 139 cc, 4 Stroke	02/2010 - on	CR6HSB	0.7	CR6HIX
8 HP 8C	2 Cyl, 1Carb, 165 cc, 2 Stroke	01/1986 - on	B7HS-10	1.0	
8 HP E8D Enduro	165 cc, 2 Stroke	1986 - on	B7HS-10	1.0	
8 HP EK8D Enduro	165 cc, 2 Stroke	1988 - on	B6HS	0.7	BR6HIX
8 HP F8B	232 cc, 4 Stroke	to - 2001	CR5HSA	0.7	
8 HP F8C	2 Cyl, 1Carb, 197 cc, 4 Stroke	01/2003 - on	BR6HS-10	1.0	
8 HP FT8D	197 cc, 4 Stroke	2001 - on	BR6HS-10	1.0	
9.9 HP 9.9D	246 cc, 2 Stroke	to - 1995	B7HS-10	1.0	
9.9 HP 9.9F	2 Cyl, 1Carb, 246 cc, 2 Stroke	01/1996 - on	B7HS-10	1.0	
9.9 HP E9.9B Enduro	246 cc, 2 Stroke	1988 - 1996	B7HS-10	1.0	
9.9 HP E9.9C Enduro	246 cc, 2 Stroke	1997 - 2002	B7HS-10	1.0	
9.9 HP E9.9D Enduro	246 cc, 2 Stroke	2002 - on	B8HS-10	1.0	
9.9 HP EK9.9D Enduro	246 cc, 2 Stroke	2003 - on	B7HS-10	1.0	
9.9 HP EK9.9H Enduro	246 cc, 2 Stroke	2003 - 2004	B7HS-10	1.0	
9.9 HP EK9.9J Enduro	246 cc, 2 Stroke	2003 - on	B7HS-10	1.0	
9.9 HP F9.9B	232 cc, 4 Stroke	1991 - 2007	CR6HSA	0.7	CR6HIX
9.9 HP F9.9C	323 cc, 4 Stroke	1998 - 2008	DPR6EA-9	0.9	
9.9 HP F9.9F	2 Cyl, 1Carb, 212 cc, 4 Stroke	07/2007 - 2013	BR6HS-10	1.0	



MARINE – OUTBOARD RANGE

Make & Model	Other	Year	Recommended Part No.	Gap (mm)	Iridium Option
YAMAHA (CONT)					
9.9 HP F9.9H	362 cc, 4 Stroke	2009 - on	DPR6EB-9	0.9	
9.9 HP F9.9J	2 Cyl, 1Carb, 212 cc, 4 Stroke	2013 - on	BR6HS-10	1.0	
9.9 HP FT9.9A	232 cc, 4 Stroke	1998 - 2007	CR6HSA	0.7	CR6HIX
9.9 HP FT9.9D	2 Cyl, 1Carb, 323 cc, 4 Stroke	01/2003 - 12/2006	DPR6EA-9	0.9	
9.9 HP FT9.9G	2 Cyl, Carb, 212 cc, 4 Stroke	01/2007 - 2013	BR6HS-10	1.0	
9.9 HP FT9.9L	2 Cyl, Carb, 212 cc, 4 Stroke	2013 - on	BR6HS-10	1.0	
13.5 HP F13.5A	323 cc, 4 Stroke	2001 - 2007	DPR6EA-9	0.9	
13.5 HP F13.5B	362 cc, 4 Stroke	2007 - 2009	DPR6EB-9	0.9	
15 HP 15D	246 cc, 2 Stroke	to - 1995	B7HS-10	1.0	
15 HP 15F	2 Cyl, 1Carb, 246 cc, 2 Stroke	01/1996 - on	B7HS-10	1.0	
15 HP E15B Enduro	246 cc, 2 Stroke	1988 - 1996	B7HS-10	1.0	
15 HP E15C Enduro	246 cc, 2 Stroke	1997 - 2002	B7HS-10	1.0	
15 HP E15D Enduro	246 cc, 2 Stroke	2002 - on	B8HS-10	1.0	
15 HP EK15D Enduro	246 cc, 2 Stroke	2003 - on	B7HS-10	1.0	
15 HP EK15H Enduro	246 cc, 2 Stroke	1989 - 1996	B7HS-10	1.0	
15 HP EK15J Enduro	246 cc, 2 Stroke	1989 - 1996	B7HS-10	1.0	
15 HP EK15N Enduro	246 cc, 2 Stroke	1994 - 2004	B7HS-10	1.0	
15 HP EK15P Enduro	246 cc, 2 Stroke	2003 - on	B7HS-10	1.0	
15 HP F15A	2 Cyl, 1Carb, 323 cc, 4 Stroke	01/2003 - 10/2006	DPR6EA-9	0.9	
15 HP F15B	323 cc, 4 Stroke	2003 - 2008	DPR6EA-9	0.9	
15 HP F15C	2 Cyl, 1Carb, 362 cc, 4 Stroke	11/2006 - on	DPR6EB-9	0.9	
20 HP 20C	430 cc, 2 Stroke	1990 - 2007	BR7HS	0.7	BR7HIX
20 HP 20D	2 Cyl, 2Carb, 395 cc, 2 Stroke	01/1988 - on	B7HS-10	1.0	
20 HP EK20F Enduro	430 cc, 2 Stroke	to - 1993	B6HS	0.7	BR6HIX
20 HP F20A	498 cc, 4 Stroke	1998 - 2009	DPR6EA-9	0.9	
20 HP F20B	2 Cyl, 1Carb, 362 cc, 4 Stroke	11/2006 - on	DPR6EB-9	0.9	
20 HP F20C	362 cc, 4 Stroke	2008 - on	DPR6EB-9	0.9	
20 HP F20D	498 cc, 4 Stroke	2011 - on	DPR6EB-9	0.9	
25 HP 25B	2 Cyl, 1Carb, 496 cc, 2 Stroke	10/2007 - on	B7HS-10	1.0	
25 HP 25D	430 cc, 2 Stroke	1990 - 2003	B7HS	0.7	BR7HIX

Make & Model	Other	Year	Recommended Part No.	Gap (mm)	Iridium Option
25 HP 25J	2 Stroke	1987 - 2003	B7HS-10	1.0	
25 HP 25N	2 Cyl, 2Carb, 395 cc, 2 Stroke	01/1988 - on	B7HS-10	1.0	
25 HP 25Q	2 Stroke	to - 1995	B8HS-10	1.0	
25 HP 25V	2 Stroke	1992 - 2001	B7HS-10	1.0	
25 HP 25X	2 Stroke	2001 - on	B8HS-10	1.0	
25 HP E25A Enduro	496 cc, 2 Stroke	to - 2001	B7HS-10	1.0	
25 HP E25B Enduro	496 cc, 2 Stroke	2001 - on	B7HS-10	1.0	
25 HP E25F Enduro	430 cc, 2 Stroke	to - 1993	B7HS	0.7	BR7HIX
25 HP EK25B Enduro	496 cc, 2 Stroke	2003 - on	B7HS-10	1.0	
25 HP EK25C Enduro	496 cc, 2 Stroke	2006 - on	B7HS-10	1.0	
25 HP EK25F Enduro	430 cc, 2 Stroke	to - 1993	B7HS	0.7	BR7HIX
25 HP F25A	2 Cyl, 1Carb, 498 cc, 4 Stroke	01/2003 - on	DPR6EA-9	0.9	
25 HP F25C	498 cc, 4 Stroke	2003 - 2009	DPR6EA-9	0.9	
25 HP F25D	498 cc, 4 Stroke	2010 - on	DPR6EB-9	0.9	
25 HP FT25B	498 cc, 4 Stroke	2000 - 2009	DPR6EA-9	0.9	
25 HP FT25F	2 Cyl, Carb, 498 cc, 4 Stroke	07/2009 - on	DPR6EB-9	0.9	
30 HP 30A	496 cc, 2 Stroke	to - 1992	B7HS	0.7	BR7HIX
30 HP 30D	3 Cyl, 3Carb, 496 cc, 2 Stroke	01/1986 - on	B7HS-10	1.0	
30 HP 30G	496 cc, 2 Stroke	1993 - 2001	B7HS-10	1.0	
30 HP 30H Enduro	2 Cyl, 1Carb, 496 cc, 2 Stroke	2001 - on	B8HS-10	1.0	
30 HP E30H Enduro	2 Cyl, 1Carb, 496 cc, 2 Stroke	2001 - on	B8HS-10	1.0	
30 HP F30A	3 Cyl, 3Carb, 747 cc, 4 Stroke	01/2003 - 04/2009	DPR6EA-9	0.9	
30 HP F30B	3 Cyl, 3Carb, 747 cc, 4 Stroke	05/2009 - on	DPR6EB-9	0.9	
40 HP 40H	698 cc, 2 Stroke	to - 1994	B7HS-10	1.0	
40 HP 40J Enduro	669 cc, 2 Stroke	1983 - on	B7HS	0.7	BR7HIX
40 HP 40Q	592 cc, 2 Stroke	to - 1998	B8HS	0.7	BR8HIX
40 HP 40V	3 Cyl, 3Carb, 698 CC, 2 Stroke	01/1995 - on	B7HS-10	1.0	
40 HP 40X Enduro	2 Cyl, 1Carb, 703 cc, 2 Stroke	1998 - on	B7HS	0.7	BR7HIX
40 HP 40Y	698 cc, 2 Stroke	2001 - on	BR8HS-10	1.0	BR8HIX
40 HP E40G Enduro	669 cc, 2 Stroke	1982 - on	B7HS	0.7	BR7HIX
40 HP E40J Enduro	669 cc, 2 Stroke	1983 - on	B7HS	0.7	BR7HIX
40 HP E40X Enduro	2 Cyl, 1Carb, 703 cc, 2 Stroke	1998 - on	B7HS	0.7	BR7HIX

Make & Model	Other	Year	Recommended Part No.	Gap (mm)	Iridium Option
YAMAHA (CONT)					
40 HP EK40G Enduro	669 cc, 2 Stroke	1998 - on	B7HS	0.7	BR7HIX
40 HP EK40J Enduro	669 cc, 2 Stroke	1998 - on	B7HS	0.7	BR7HIX
40 HP F40A	935 cc, 4 Stroke	1998 - 2002	DPR6EA-9	0.9	
40 HP F40B	3 Cyl, 3Carb, 747 cc, 4 Stroke	01/2003 - 04/2009	DPR6EA-9	0.9	
40 HP F40C	996 cc, 4 Stroke	2000 - 2007	DPR5EA-9	0.9	
40 HP F40D	996 cc, 4 Stroke	2006 - on	DPR6EB-9	0.9	
40 HP F40F	3 Cyl, EFI, 747 cc, 4 Stroke	02/2009 - on	DPR6EB-9	0.9	
40 HP F40G	996 cc, 4 Stroke	2011 - on	LKR7E	0.9	
48 HP E48C Enduro	760 cc, 2 Stroke	1992 - on	B7HS	0.7	BR7HIX
50 HP 50D	698 cc, 2 Stroke	to - 1994	B8HS-10	1.0	
50 HP 50EK Enduro	849 cc, 2 Stroke	1988 - 1997	B8HS-10	1.0	
50 HP 50G	849 cc, 2 Stroke	1993 - 2007	BR8HS-10	1.0	BR8HIX
50 HP 50H	3 Cyl, 3Carb, 698 cc, 2 Stroke	01/1995 - on	B8HS-10	1.0	
50 HP F50A	4 Cyl, 4Carb, 935 cc, 4 Stroke	01/2003 - 06/2005	DPR6EA-9	0.9	
50 HP F50D	935 cc, 4 Stroke	2001 - on	DPR6EA-9	0.9	
50 HP F50F	4 Cyl, EFI, 996 cc, 4 Stroke	07/2004 - 2013	DPR6EB-9	0.9	
50 HP F50H	4 Cyl, EFI, 996 cc, 4 Stroke	2013 - on	DPR6EB-9	0.9	
50 HP FT50B	935 cc, 4 Stroke	1998 - 2006	DPR6EA-9	0.9	
50 HP FT50C	935 cc, 4 Stroke	2001 - on	DPR6EA-9	0.9	
50 HP FT50G	4 Cyl, EFI, 996 cc, 4 Stroke	2005 - 2013	DPR6EB-9	0.9	
50 HP FT50J	4 Cyl, EFI, 996 cc, 4 Stroke	2013 - on	DPR6EB-9	0.9	
55 HP 55B	760 cc, 2 Stroke	1989 - on	B8HS-10	1.0	
55 HP 55D	1140 cc, 2 Stroke	1998 - on	B8HS-10	1.0	
55 HP E55C Enduro	760 cc, 2 Stroke	1992 - on	B8HS	0.7	BR8HIX
60 HP 60F	3 Cyl, 3Carb, 849 cc, 2 Stroke	01/1992 - on	B8HS-10	1.0	
60 HP E60H Enduro	3 Cyl, 3Carb, 849 cc, 2 Stroke	1986 - on	B8HS-10	1.0	
60 HP E60J Enduro	1140 cc, 2 Stroke	1995 - on	B8HS-10	1.0	
60 HP F60A	4 Cyl, 4Carb, 996 cc, 4 Stroke	01/2003 - 06/2005	DPR5EA-9	0.9	
60 HP F60C	4 Cyl, EFI, 996 cc, 4 Stroke	07/2004 - on	DPR6EB-9	0.9	
60 HP F60F	4 Cyl, EFI, 996 cc, 4 Stroke	2013 - on	DPR6EB-9	0.9	

Make & Model	Other	Year	Recommended Part No.	Gap (mm)	Iridium Option
60 HP FT60B	996 cc, 4 Stroke	2002 - 2007	DPR5EA-9	0.9	
60 HP FT60D	4 Cyl, EFI, 996 cc, 4 Stroke	10/2007 - 2013	DPR6EB-9	0.9	
60 HP FT60G	4 Cyl, EFI, 996 cc, 4 Stroke	2013 - on	DPR6EB-9	0.9	
65 HP E65A Enduro	1140 cc, 2 Stroke	1998 - on	BR8HS-10	1.0	BR8HIX
70 HP 70B	3 Cyl, 3Carb, 849 cc, 2 Stroke	01/1992 - on	B8HS-10	1.0	
70 HP 70C	847 cc, 2 Stroke	1992 - 2001	B8HS-10	1.0	
70 HP F70A	4 Cyl, EFI, 996 cc, 4 Stroke	2011 - on	LKR7E	0.9	
75 HP 75A	3 Cyl, 3Carb, 1140 cc, 2 Stroke	01/1994 - 06/2004	B8HS-10	1.0	
75 HP 75C	1140 cc, 2 Stroke	1996 - on	B8HS-10	1.0	
75 HP E75B Enduro	1140 cc, 2 Stroke	1991 - on	B8HS-10	1.0	
75 HP F75A	1596 cc, 4 Stroke	2002 - 2004	LFR5A-11	1.1	LFR5AIX-11
75 HP F75B	1596 cc, 4 Stroke	2005 - on	LFR5A-11	1.1	LFR5AIX-11
75 HP F75C	1596 cc, 4 Stroke	2008 - on	LFR5A-11	1.1	LFR5AIX-11
80 HP 80A	1140 cc, 2 Stroke	1992 - 2003	B8HS-10	1.0	
80 HP F80A	4 Cyl, 4Carb, 1596 cc, 4 Stroke	01/2003 - 06/2005	LFR5A-11	1.1	LFR5AIX-11
80 HP F80B	4 Cyl, EFI, 1596 cc, 4 Stroke	07/2004 - on	LFR5A-11	1.1	LFR5AIX-11
80 HP F80C	1596 cc, 4 Stroke	2009 - on	LFR5A-11	1.1	LFR5AIX-11
85 HP 85A	3 Cyl, 3Carb, 1140 cc, 2 Stroke	01/1989 - 06/2004	B8HS-10	1.0	
90 HP 90A	3 Cyl, 3Carb, 1140 cc, 2 Stroke	01/1992 - on	B8HS-10	1.0	
90 HP F90A	1596 cc, 4 Stroke	2002 - 2004	LFR5A-11	1.1	LFR5AIX-11
90 HP F90B	1596 cc, 4 Stroke	2005 - on	LFR5A-11	1.1	LFR5AIX-11
100 HP 100A	1730 cc, 2 Stroke	1996 - 2001	B8HS-10	1.0	
100 HP F100A	4 Cyl, 4Carb, 1596 cc, 4 Stroke	01/1999 - 06/2005	LFR5A-11	1.1	LFR5AIX-11
100 HP F100B	1596 cc, 4 Stroke	2002 - on	LFR5A-11	1.1	LFR5AIX-11
100 HP F100C	1596 cc, 4 Stroke	2002 - 2007	LFR5A-11	1.1	LFR5AIX-11
100 HP F100D	4 Cyl, EFI, 1596 cc, 4 Stroke	07/2005 - on	LFR5A-11	1.1	LFR5AIX-11
115 HP 115B	1730 cc, 2 Stroke	1984 - on	B8HS-10	1.0	
115 HP 115C	V4 Cyl, 2Carb, 1730 cc, 2 Stroke	01/1984 - on	BR8HS-10	1.0	BR8HIX
115 HP E115A Enduro	1730 cc, 2 Stroke	1992 - on	B8HS-10	1.0	
115 HP F115A	4 Cyl, EFI, 1741 cc, 4 Stroke	01/2000 - on	LFR6A-11	1.1	LFR6AIX-11



MARINE – OUTBOARD RANGE

Make & Model	Other	Year	Recommended Part No.	Gap (mm)	Iridium Option
YAMAHA (CONT)					
115 HP F115B	4 Cyl., EFI, 1832 cc, 4 Stroke	2014 - on	LKR6E	0.9	
115 HP FL115A	4 Cyl, EFI, 1741 cc, 4 Stroke	01/2000 - on	LFR6A-11	1.1	LFR6AIX-11
115 HP FL115B	4 Cyl, EFI, 1832 cc, 4 Stroke	2013 - on	LKR6E	0.9	
130 HP 130B	V4 Cyl, 2Carb, 1730 cc, 2 Stroke	01/1991 - on	BR9HS-10	1.0	BR9HIX
130HP L130B	V4 Cyl, 2Carb, 1730 cc, 2 Stroke	01/1991 - on	BR9HS-10	1.0	BR9HIX
140HP 140B	1730 cc, 2 Stroke	1992 - on	B9HS-10	1.0	
140HP 140C	1730 cc, 2 Stroke	1993 - 2003	B9HS-10	1.0	
150 HP 150A	2596 cc, 2 Stroke	1983 - on	B8HS-10	1.0	
150 HP 150C	2596 cc, 2 Stroke	1990 - 1995	B8HS-10	1.0	
150 HP 150D	2596 cc, 2 Stroke	1991 - 1995	B8HS-10	1.0	
150 HP 150F	V6 Cyl, 3Carb, 2596 cc, 2 Stroke	01/1996 - on	BR7HS-10	1.0	BR7HIX
150 HP 150G	2596 cc, 2 Stroke	1996 - on	BR7HS-10	1.0	BR7HIX
150 HP 150J	2596 cc, 2 Stroke	2000 - 2006	BR7HS-10	1.0	BR7HIX
150 HP 150L	2596 cc, 2 Stroke	2000 - 2005	BR7HS-10	1.0	BR7HIX
150 HP D150H	2596 cc, 2 Stroke	1998 - 2003	BR8HS-10	1.0	BR8HIX
150 HP D150N	2596 cc, 2 Stroke	2000 - 2005	BR7HS-10	1.0	BR7HIX
150 HP L150A	2596 cc, 2 Stroke	1983 - on	B8HS-10	1.0	
150 HP L150C	2596 cc, 2 Stroke	1990 - 1995	B8HS-10	1.0	
150 HP L150F	V6 Cyl, 3Carb, 2596 cc, 2 Stroke	01/1996 - on	BR7HS-10	1.0	BR7HIX
150 HP L150J	2596 cc, 2 Stroke	2000 - 2006	BR7HS-10	1.0	BR7HIX
150 HP LZ150P	V6 Cyl, DFI, 2596 cc, 2 Stroke	01/2000 - on	BKR6EKU	1.6	
150 HP S150F	V6 Cyl, 3Carb, 2596 cc, 2 Stroke	01/1997 - on	BR7HS-10	1.0	BR7HIX
150 HP SL150F	V6 Cyl, 3Carb, 2596 cc, 2 Stroke	01/1997 - on	BR7HS-10	1.0	BR7HIX
150 HP Z150P	V6 Cyl, DFI, 2596 cc, 2 Stroke	01/2000 - on	BKR6EKU	1.6	
150 HP Z150Q	2596 cc, 2 Stroke	2000 - on	BKR6EKU	1.6	
150 HP F150A	4 Cyl, EFI, 2670 cc, 4 Stroke	07/2003 - on	LFR5A-11	1.1	LFR5AIX-11
150 HP F150B	2670 cc, 4 Stroke	2009 - on	LFR5A-11	1.1	LFR5AIX-11
150 HP F150C	4 Cyl., EFI, 2785 cc, 4 Stroke	2013 - on	LFR6A-11	1.1	LFR6AIX-11
150 HP FL150A	4 Cyl, EFI, 2670 cc, 4 Stroke	07/2003 - on	LFR5A-11	1.1	LFR5AIX-11

Make & Model	Other	Year	Recommended Part No.	Gap (mm)	Iridium Option
150 HP FL150B	2670 cc, 4 Stroke	2009 - on	LFR5A-11	1.1	LFR5AIX-11
175 HP 175A	2596 cc, 2 Stroke	1983 - 2008	B8HS-10	1.0	
175 HP 175B	2596 cc, 2 Stroke	1990 - 1995	B8HS-10	1.0	
175 HP 175C	2596 cc, 2 Stroke	1991 - 1995	B8HS-10	1.0	
175 HP 175D	V6 Cyl, 3Carb, 2596 cc, 2 Stroke	01/1996 - 12/2006	BR8HS-10	1.0	BR8HIX
175 HP 175F	2596 cc, 2 Stroke	1996 - 2005	BR8HS-10	1.0	BR8HIX
175 HP F175A	4 Cyl., EFI, 2785 cc, 4 Stroke	2013 - on	LFR6A-11	1.1	LFR6AIX-11
175 HP S175D	V6 Cyl, 3Carb, 2596 cc, 2 Stroke	01/1997 - on	BR8HS-10	1.0	BR8HIX
175 HP Z175G	V6 Cyl, DFI, 2596 cc, 2 Stroke	01/2000 - on	BKR7EKU	1.6	
175 HP Z175H	2596 cc, 2 Stroke	2001 - on	BKR7EKU	1.6	
200 HP 200A	2596 cc, 2 Stroke	1983 - on	B8HS-10	1.0	
200 HP 200B	2596 cc, 2 Stroke	1990 - 1995	B8HS-10	1.0	
200 HP 200C	2596 cc, 2 Stroke	1991 - 1995	B8HS-10	1.0	
200 HP 200F	V6 Cyl, 3Carb, 2596 cc, 2 Stroke	01/1996 - on	BR8HS-10	1.0	BR8HIX
200 HP 200G	2596 cc, 2 Stroke	1996 - on	BR8HS-10	1.0	BR8HIX
200 HP 200H	2596 cc, 2 Stroke	1998 - 2005	BR8HS-10	1.0	BR8HIX
200 HP 200J	2596 cc, 2 Stroke	2000 - 2005	BR8HS-10	1.0	BR8HIX
200 HP L200A	2596 cc, 2 Stroke	1983 - on	B8HS-10	1.0	
200 HP L200B	2596 cc, 2 Stroke	1990 - 1995	B8HS-10	1.0	
200 HP L200F	V6 Cyl, 3Carb, 2596 cc, 2 Stroke	01/1996 - on	BR8HS-10	1.0	BR8HIX
200 HP L200J	2596 cc, 2 Stroke	2000 - 2005	BR8HS-10	1.0	BR8HIX
200 HP LZ200N	V6 Cyl, DFI, 2596 cc, 2 Stroke	01/2000 - on	BKR7EKU	1.6	
200 HP S200F	V6 Cyl, 3Carb, 2596 cc, 2 Stroke	01/1997 - 2003	BR8HS-10	1.0	BR8HIX
200 HP SL200F	V6 Cyl, 3Carb, 2596 cc, 2 Stroke	01/1997 - 2003	BR8HS-10	1.0	BR8HIX
200 HP Z200N	V6 Cyl, DFI, 2596 cc, 2 Stroke	01/2000 - on	BKR7EKU	1.6	
200 HP Z200P	2596 cc, 2 Stroke	2001 - on	BKR7EKU	1.6	
200 HP Z200Q	2596 cc, 2 Stroke	2005 - 2007	BKR7EKU	1.6	
200 HP Z200R	3342 cc, 2 Stroke	2005 - on	BKR6EKU	1.6	
200 HP F200A	V6 Cyl, EFI, 3352 cc, 4 Stroke	01/2002 - on	LFR5A-11	1.1	LFR5AIX-11
200 HP F200B	3352 cc, 4 Stroke	2007 - 2012	LFR5A-11	1.1	LFR5AIX-11
	3352 cc, 4 Stroke	2013 - on	LFR6A-11	1.1	LFR6AIX-11
200 HP F200C	3352 cc, 4 Stroke	2007 - on	LFR6A-11	1.1	LFR6AIX-11

Make & Model	Other	Year	Recommended Part No.	Gap (mm)	Iridium Option
YAMAHA (CONT)					
200 HP F200D	V6 Cyl, MPFI, 4169 cc, 4 Stroke	01/2010 - on	LFR6A-11	1.1	LFR6AIX-11
200 HP F200F	4 Cyl, EFI, 2785 cc, 4 Stroke	2013 - on	LFR6A-11	1.1	LFR6AIX-11
200 HP F200G	4 Cyl, EFI, 2785 cc, 4 Stroke	2013 - on	LFR6A-11	1.1	LFR6AIX-11
200 HP FL200A	V6 Cyl, EFI, 3352 cc, 4 Stroke	01/2002 - on	LFR5A-11	1.1	LFR5AIX-11
200 HP FL200B	3352 cc, 4 Stroke	2007 - 2012	LFR5A-11	1.1	LFR5AIX-11
	3352 cc, 4 Stroke	2013 - on	LFR6A-11	1.1	LFR6AIX-11
200 HP FL200C	3352 cc, 4 Stroke	2007 - on	LFR6A-11	1.1	LFR6AIX-11
200 HP FL200F	4 Cyl, EFI, 2785 cc, 4 Stroke	2013 - on	LFR5A-11	1.1	LFR5AIX-11
200 HP FL200G	4 Cyl, EFI, 2785 cc, 4 Stroke	2013 - on	LFR6A-11	1.1	LFR6AIX-11
225 HP 225B	2596 cc, 2 Stroke	to - 1995	BR9HS-10	1.0	BR9HIX
225 HP 225C	3130 cc, 2 Stroke	1994 - 2004	BR9HS-10	1.0	BR9HIX
225 HP 225D	2596 cc, 2 Stroke	1996 - on	BR8HS-10	1.0	BR8HIX
225 HP 225F	V6 Cyl, EFI, 3130 cc, 2 Stroke	01/1997 - 12/2006	BR9HS-10	1.0	BR9HIX
225 HP 225G	3130 cc, 2 Stroke	1998 - 2004	BR9HS-10	1.0	BR9HIX
225 HP L225C	3130 cc, 2 Stroke	1994 - 2004	BR9HS-10	1.0	BR9HIX
225 HP L225F	V6 Cyl, EFI, 3130 cc, 2 Stroke	01/1997 - 12/2006	BR9HS-10	1.0	BR9HIX
225 HP Z225H	3342 cc, 2 Stroke	2004 - on	BKR6EKU	1.6	
225 HP F225A	V6 Cyl, EFI, 3352 cc, 4 Stroke	01/2002 - 05/2010	LFR5A-11	1.1	LFR5AIX-11
225 HP F225B	3352 cc, 4 Stroke	2007 - on	LFR6A-11	1.1	LFR6AIX-11
225 HP F225C	3352 cc, 4 Stroke	2008 - on	LFR6A-11	1.1	LFR6AIX-11
225 HP F225D	V6 Cyl, MPFI, 4169 cc, 4 Stroke	01/2010 - on	LFR6A-11	1.1	LFR6AIX-11
225 HP F225F	V6 Cyl, EFI, 4169 cc, 4 Stroke	06/2010 - on	LFR6A-11	1.1	LFR6AIX-11
225 HP FL225A	V6 Cyl, EFI, 3352 cc, 4 Stroke	01/2002 - 05/2010	LFR5A-11	1.1	LFR5AIX-11
225 HP FL225B	3352 cc, 4 Stroke	2007 - on	LFR6A-11	1.1	LFR6AIX-11
225 HP FL225F	V6 Cyl, EFI, 4169 cc, 4 Stroke	06/2010 - on	LFR6A-11	1.1	LFR6AIX-11
250 HP 250A	V6 Cyl, 6Carb, 3130 cc, 2 Stroke	01/1990 - 12/2006	BR8HS-10	1.0	BR8HIX
250 HP 250B	V6 Cyl, EFI, 3130 cc, 2 Stroke	01/1997 - 12/2006	BR9HS-10	1.0	BR9HIX
250 HP 250C	3130 cc, 2 Stroke	2003 - 2004	BR9HS-10	1.0	BR9HIX
250 HP 250G	3130 cc, 2 Stroke	2006 - on	BR8HS-10	1.0	BR8HIX

Make & Model	Other	Year	Recommended Part No.	Gap (mm)	Iridium Option
250 HP L250A	V6 Cyl, 6Carb, 3130 cc, 2 Stroke	01/1990 - 12/2006	BR8HS-10	1.0	BR8HIX
250 HP L250B	V6 Cyl, EFI, 3130 cc, 2 Stroke	01/1997 - 12/2006	BR9HS-10	1.0	BR9HIX
250 HP L250G	3130 cc, 2 Stroke	2006 - on	BR8HS-10	1.0	BR8HIX
250 HP LZ250D	V6 Cyl, DFI, 3342 cc, 2 Stroke	01/2002 - 12/2007	BKR6EKU	1.6	
250 HP SL250A	3130 cc, 2 Stroke	1997 - 2006	BR9HS-10	1.0	BR9HIX
250 HP Z250D	V6 Cyl, DFI, 3342 cc, 2 Stroke	01/2002 - 12/2007	BKR6EKU	1.6	
250 HP Z250F	3342 cc, 2 Stroke	2002 - on	BKR6EKU	1.6	
250 HP F250A	V6 Cyl, EFI, 3352 cc, 4 Stroke	07/2005 - on	LFR6A-11	1.1	LFR6AIX-11
250 HP F250B	V6 Cyl, EFI, 3352 cc, 4 Stroke	07/2008 - 05/2010	LFR6A-11	1.1	LFR6AIX-11
250 HP F250C	V6 Cyl, EFI, 4169 cc, 4 Stroke	01/2010 - on	LFR6A-11	1.1	LFR6AIX-11
250 HP F250D	V6 Cyl, EFI, 4169 cc, 4 Stroke	06/2010 - on	LFR6A-11	1.1	LFR6AIX-11
250 HP F250G	3352 cc, 4 Stroke	2012 - on	LFR6A-11	1.1	LFR6AIX-11
250 HP FL250A	V6 Cyl, EFI, 3352 cc, 4 Stroke	07/2005 - on	LFR6A-11	1.1	LFR6AIX-11
250 HP FL250B	V6 Cyl, EFI, 3352 cc, 4 Stroke	11/2008 - 05/2010	LFR6A-11	1.1	LFR6AIX-11
250 HP FL250D	V6 Cyl, EFI, 4169 cc, 4 Stroke	06/2010 - on	LFR6A-11	1.1	LFR6AIX-11
250 HP FL250G	3352 cc, 4 Stroke	2012 - on	LFR6A-11	1.1	LFR6AIX-11
300 HP LZ300A	V6 Cyl, DFI, 3342 cc, 2 Stroke	01/2003 - 2008	BKR6EKU	1.6	
300 HP Z300A	V6 Cyl, DFI, 3342 cc, 2 Stroke	01/2003 - 2008	BKR6EKU	1.6	
300 HP Z300B	3342 cc, 2 Stroke	2003 - on	BKR6EKU	1.6	
300 HP F300A	V8 Cyl, MPFI, 5330 cc, 4 Stroke	11/2008 - on	LFR6A-11	1.1	LFR6AIX-11
300 HP F300B	V6 Cyl, EFI, 4169 cc, 4 Stroke	06/2010 - on	LFR6A-11	1.1	LFR6AIX-11
300 HP FL300A	V8 Cyl, EFI, 5330 cc, 4 Stroke	11/2008 - on	LFR6A-11	1.1	LFR6AIX-11
300 HP FL300B	V6 Cyl, EFI, 4169 cc, 4 Stroke	06/2010 - on	LFR6A-11	1.1	LFR6AIX-11
350 HP F350A	V8 Cyl, EFI, 5330 cc, 4 Stroke	10/2007 - on	LFR6A-11	1.1	LFR6AIX-11
350 HP FL350A	V8 Cyl, EFI, 5330 cc, 4 Stroke	11/2008 - on	LFR6A-11	1.1	LFR6AIX-11



NOTES

PLATINUM

DURABILITY

FUTURE

TECH

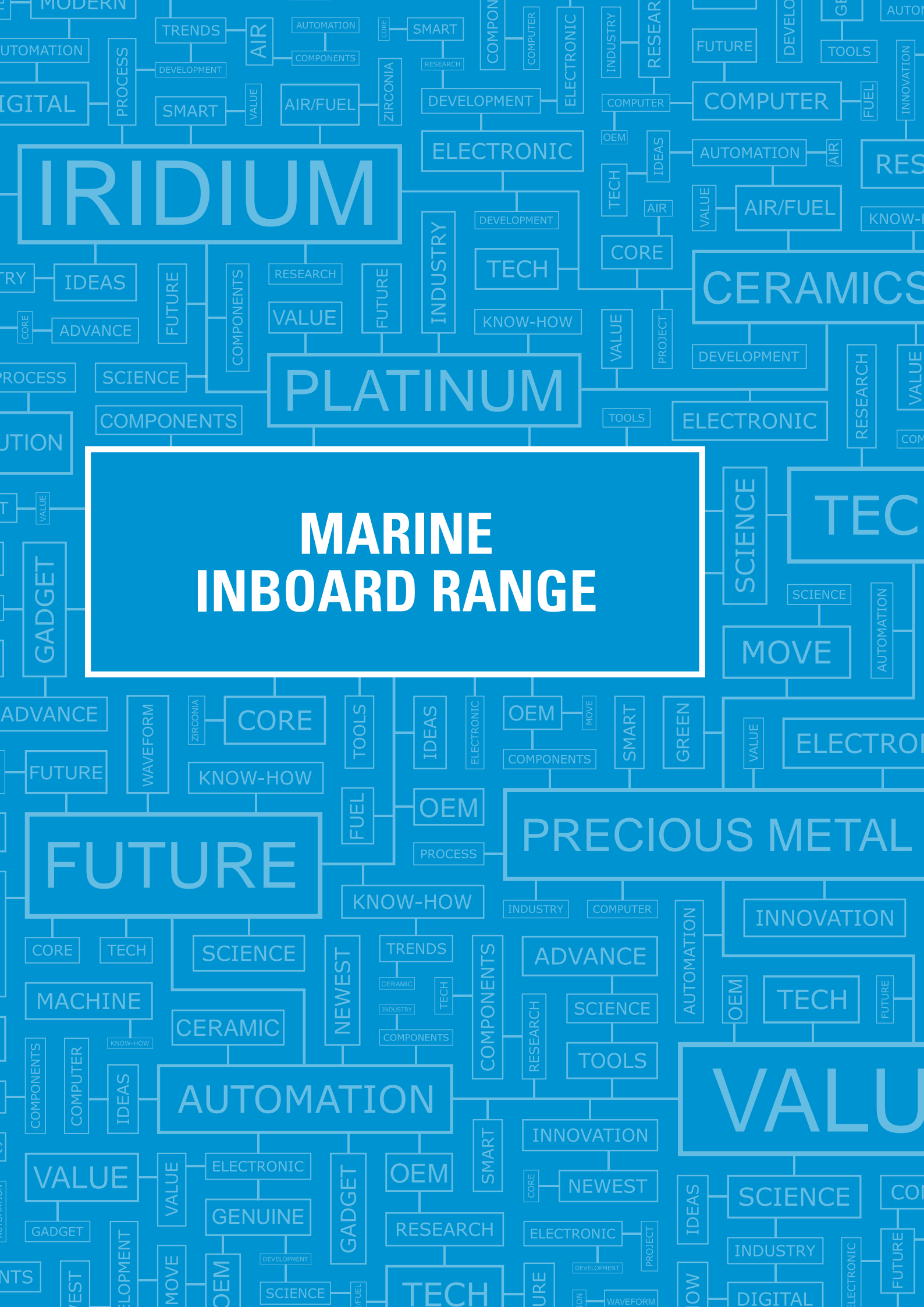

IRIDIUM

PLATINUM

CERAMICS

MARINE INBOARD RANGE

ELECTRONICS

PRECIOUS METAL

FUTURE

VALUABLE

AUTOMATION

VALUE

TECH

SCIENCE

TECH

DIGITAL



MARINE – INBOARD RANGE

Make & Model	Other	Year	Recommended Part No.	Gap (mm)	Iridium Option
BARR					
Buick Engines					
455 cu.in		1974-71	BR5FS	0.9	
		1970	BR6FS	0.8	
Chevrolet Engines					
6 cyl.292 cu.in		1974-70	BR6FS	0.9	
6 cyl.250 cu.in		1974-70	BR5FS	0.9	
6 cyl.230 cu.in		1970	BR6FS	0.9	
V-8 427 cu.in		1972-71	BP7FS	0.9	
V-8 400 cu.in		1974-71	BP6FS	0.9	UR6IX
		1970	BP5S	0.9	XR5IX
V-8 350 cu.in		1974-71	BR6FS	0.9	
V-8 350 cu.in.4 bbl		1970	BP6S	0.9	
V-8 350 cu.in.2 bbl		1970-67	BP5S	0.8	XR5IX
V-8 307 cu.in		1973-71	BR5FS	0.9	
		1970-68	BP5S	0.9	XR5IX
Chrysler Engines					
440 cu.in		1974-66	BP5S	0.9	XR5IX
383 cu.in		1971-60	BP5S	0.9	XR5IX
Oldsmobile Engines					
455 cu.in		1978-76	BP-4	1.0	XR4IX
455 cu.in.(4 bbl)		1974-72	BP-4	1.0	XR4IX
455 cu.in.Hi-Perf		1974-72	BP5S	1.0	XR5IX
455 cu.in.(4 bbl)		1971	BP5S	1.0	XR5IX
455 cu.in.(2 bbl)		1971	BP-4	1.0	XR4IX
455 cu.in.(4 bbl)		1970	BP5S	0.8	XR5IX
455 cu.in.(2 bbl)		1970-68	BP5S	0.8	XR5IX
350 cu.in		1974-71	BP5S	1.0	XR5IX
Pontiac Engines					
455 cu.in		1974-72	BR5FS	1.0	
455 cu.in.(2 bbl)		1971	BP-4	0.9	XR4IX
455 cu.in.(4 bbl)		1971-70	BP5S	0.9	XR5IX
400 cu.in		1974-72	BR5FS	1.0	
		1971-67	BP5S	0.9	XR5IX
BLMC					
850 Se Prince 2912 cc			BP6ES	0.6	BPR6EIX
950			B6ES	0.6	
1100	Vedette		BR6ES	0.6	
1678, 3000 cc			B6ES	0.6	
CHEVROLET					
6 Cylinder Engines					
194 cu. in.		1964-69	BPR5ES	0.8	BPR5EIX
230 cu. in.		1962-69	BPR5ES	0.8	BPR5EIX
		1970	BR6FS	0.9	
250 cu. in.		1962-69	BPR5ES	0.8	BPR5EIX
		1970-78	BPR5FS	0.9	UR5IX
292 cu. in.		1963-69	BR6ES	0.8	
		1970-90	BR6FS	0.9	

Make & Model	Other	Year	Recommended Part No.	Gap (mm)	Iridium Option
V8 Engines					
283 cu. in.		1955-67	BP5S	0.9	XR5IX
302 cu. in.		1967-69	BP5S	0.9	XR5IX
307 cu. in.		1968-70	BP5S	0.9	XR5IX
		1971-73	BR6FS	0.9	
327 cu. in.		1961-69	BR6S	0.9	
350 cu. in. (2 bbl)		1967-70	BP5S	0.9	XR5IX
350 cu. in. (4 bbl)		1970	BP5S	0.9	XR5IX
350 cu. in.		1971-90	BR6FS	0.9	
400 cu. in.		1970	BP5S	0.9	XR5IX
		1971-90	BR6FS	0.9	
427 cu. in.		1971-72	BP6FS	0.9	UR6IX
		1973-90	BR6FS	0.9	
454 cu. in.		1979-90	BR6FS	0.9	
CHRIS-CRAFT					
A, B, BA, C, H, K, KB	Regular Heads		B6S	0.7	
	Alum. Heads		B-6L	0.7	
KBL, KC, KFL, KL, KLC	Regular Heads		B6S	0.7	
	Alum. Heads		B-6L	0.7	
LC, LD, M, MB, MBL	Regular Heads		B6S	0.7	
	Alum. Heads		B-6L	0.7	
MC, MCL, ML, W, WB	Regular Heads		B6S	0.7	
	Alum. Heads		B-6L	0.7	
153			BR6ES	0.9	
181	Through S/N 603191		BR6ES	0.9	
	From S/N 603192		BPR6FS	0.9	UR6IX
225			BP6S	0.9	
283, 302, 307, 327	Gasket Heads		B6S	0.6	
307, 350, 454	Tapered Seats		BPR6FS	0.6	UR6IX
350 Hi-Perf.			BR6FS	0.9	
427, 431 Series			A6FS	0.8	
430 Series			AP6FS	0.8	
CHRYSLER					
4 cyl. M91D, M91F			BP6ES	0.9	BPR6EIX
4 cyl. M122A, M122B			B7HS	0.7	BR7HIX
6 cyl. M 46-3, M46-4, M46S-3			BR6S	0.9	
6 cyl. M47-3, M47-4, M47S-3			BR6S	0.9	
6 cyl. M170			BR6ES	0.9	
6 cyl. M183B			B7HS	0.7	BR7HIX
6 cyl. M225A, M225GD, MH225D			BR6ES	0.9	
6 cyl. M225D		1976 on	BPR6FS	0.9	UR6IX
		to 1975	BR6ES	0.9	

Make & Model	Other	Year	Recommended Part No.	Gap (mm)	Iridium Option
CHRYSLER (CONT)					
6 cyl. M265, M265A			BR6S	0.9	
M426-Ski			BP5S	0.9	XR5IX
M426B			BP5S	0.9	XR5IX
M426D			BP5S	0.9	XR5IX
M440B			BP5S	0.9	XR5IX
M440BJ			BP5S	0.9	XR5IX
M440BV			BP5S	0.9	XR5IX
M440D			BP5S	0.9	XR5IX
M440S			BP5S	0.9	XR5IX
M440SV			BP5S	0.9	XR5IX
M460B			BPR6FS	0.9	UR6IX
V-8 LM318A, LM318AC, LM318B			BPR6ES	0.9	BPR6EIX
V-8 LM318BC, LM318BJ, LM318BT			BPR6ES	0.9	BPR6EIX
V-8 LM318BV, LM318D			BPR6ES	0.9	BPR6EIX
V-8 LM340B, LM340BJ, LM340BT			BPR6ES	0.9	BPR6EIX
V-8 LM340BV			BPR6ES	0.9	BPR6EIX
V-8 M44, M44-3			BR6S	0.9	
V-8 M45, M45-3, M45S, M45S-3			BR6ES	0.9	
V-8 M45SP-3			BR6ES	0.9	
V-8 M80			BP6S	0.9	
V-8 M81			BR6ES	0.9	
V-8 M273A, M273B, M273BT			BPR6ES	0.9	BPR6EIX
V-8 M318A, M318B, M318C, M318GD			BP6S	0.9	
V-8 M-360A			BPR6ES	0.9	BPR6EIX
V-8 M360B, M360BC, M360BJ			BPR6ES	0.9	BPR6EIX
V-8 M360BT, M360BV			BPR6ES	0.9	BPR6EIX
V-8 M383B, M383BV			BP6S	0.9	
V-8 M400B, M400BV, M400S			BP6S	0.9	
V-8 M413B, M413D			BP6S	0.9	
V-8 M413E			BR6ES	0.9	
V-8 M-426B, M-426D, M-426SKI			BP5S	0.9	XR5IX
V-8 M-440B, M-440BJ, M-440BV			BP5S	0.9	XR5IX
V-8 M-440D, M-440S			BP5S	0.9	XR5IX
V-8 M460B			BPR5FS	0.9	UR5IX
CHRYSLER VOLVO					
110, 115, 120, 130, 165, 170			B7HS	0.7	BR7HIX
CLAE					
Bantam 3 & 4 HP			AB-6	0.8	
Clae C35, 35A			B6S	0.8	
Clae Holden 25/50 using 3/8" Reach			BP5S	0.8	XR5IX
Falcon Conversion			AP5FS	0.8	
Fisherman Six 5/6 HP			AB-6	0.8	

Make & Model	Other	Year	Recommended Part No.	Gap (mm)	Iridium Option
Fisherman Ten 10/12 HP			AB-6	0.8	
Holden Conversion using 3/4" Reach			BP5ES	0.8	BPR5EIX
Valiant Conversion			B6ES	0.8	
CLIMAX					
98 cu. in.			BPR6ES	0.8	BPR6EIX
302, 351 cu. in.			A6FS	0.8	
460 cu. in.			APR6FS	0.8	
CRUSADER					
200 cu. in.		1979	BP6FS	0.9	UR6IX
229 cu. in.		1979-80	BP6FS	0.9	UR6IX
		1981-84	BPR6FS	0.9	UR6IX
262 cu. in.		1985-98	BPR6FS	0.9	UR6IX
292 cu. in.		1971-80	BP7FS	0.9	
302 cu. in.		1974-75	AR6FS	0.8	
305 cu. in. Model 190, 220		1976-96	BPR6FS	0.9	UR6IX
307 cu. in. Model 210		1971-80	BP7FS	0.9	
350 cu. in. Model 270		1971-98	BPR6FS	0.9	UR6IX
351 cu. in. 255		1974-75	AR6FS	0.8	
427 cu. in.		1968-80	BP7FS	0.9	
454 cu. in.		1972-80	BP6FS	0.9	UR6IX
		1981-98	BPR6FS	0.9	UR6IX
Charger Series					
CS185, CS220, CS250			B6S	0.6	
CS280			B6ES	0.6	
320			B6ES	0.6	
Boat Builder Series					
185, 190, 220, 230, 250			B6S	0.6	
280			B6ES	0.9	
Mark 140, 170, 200, 225			B6S	0.6	
Models 170J, 185, 200J, 210, 230, 230J			B6S	0.6	
Mark 275, 300, 325			B7S	0.8	
Mark 240, Model 280			B6ES	0.8	
CS100, CS150, CS165, CS280			B6ES	0.8	
CS180, CS220, CS250, GM, Cadillac			B6S	0.8	
CS320			B6ES	0.8	
FORD (AUST. & USA)					
18mm Head (Gasket Seat)			AB-6	0.8	
Falcon conversion 6-Cyl 144c.i.-221c.i.			AP5FS	0.9	
Falcon 250c.i. (Non X Flow)			APR6FS	0.9	
Falcon 250c.i. (X Flow Iron Head)			BPR6FS	0.9	UR6IX
Falcon 250c.i. (X Flow Alloy Head)			BPR6ES	0.9	BPR6EIX
Falcon 302C, 351C (Cleveland)	14mm Taper Seat		BPR6FS	0.9	UR6IX
Falcon 302W, 351W, (Windsor)	14mm Taper Seat		BPR6FS	0.8	UR6IX



MARINE – INBOARD RANGE

Make & Model	Other	Year	Recommended Part No.	Gap (mm)	Iridium Option
FORD (AUST. & USA)					
Falcon 302W, 351W, (Windsor)	18mm Taper Seat		APR6FS	0.8	
OHV 272, 292 cu. in. V8, 312 c.i.			AP6FS	0.8	
V8 Side Valve (Mercury, Customs)			B-6L	0.8	
67, 98 cu. in.			BPR6ES	0.8	BPR6EIX
104 cu. in.			BPR5ES	0.8	BPR5EIX
158, 201 cu. in.			B6ES	0.8	
172 cu. in.			B-6L	0.8	
250 cu. in.			AR6FS	0.9	
302, 351, 460 cu. in.		1975-89	BPR5FS	0.9	UR5IX
302, 351W, 427 cu. in.		to 1974	AR6FS	0.9	
427, 429 cu. in.		1975-89	BPR5FS	0.9	UR5IX
460 c.i. 14mm Taper Seat			BPR5FS	0.9	UR5IX
477 cu. in.		to 1976	AR6FS	0.9	
		1977-81	AR6FS	0.9	
FORD (ENGLISH)					
18mm Head			AB-6	0.8	
112E, 115E, 125E, 3004E			B5ES	0.8	
Anglia OHV 105-E, 109-E			B5ES	0.8	
Consul			BP5ES	0.8	BPR5EIX
Side Valve 4 cyl.			B6HS	0.8	BR6HIX
Zephyr			BP5ES	0.8	BPR5EIX
HOLDEN (CONVERSION)					
All 3/8" Reach Head Models			BP5S	0.8	XR5IX
All 1/2" Reach Tapered Seat Models			BP6FS	0.9	UR6IX
All 3/4" Reach Head Models			BP6ES	0.9	BPR6EIX
All .708" Reach Tapered Seat Models			BP6EFS	0.9	BPR6EFIX-10
INTERCEPTOR					
144 Continuous high speed			AP6FS	0.8	
144 (Side draft carb)			AP5FS	0.8	
170 (Down draft carb)			A6FS	0.8	
200			A6FS	0.8	
256			A6FS	0.8	
260			AP7FS	0.8	
270 (Side draft carb)			AP5FS	0.8	
272, 289, 292			A6FS	0.8	
302			AP6FS	0.8	
312, 352			A6FS	0.8	
390			AP6FS	0.8	
427, 300HP Normal operation			A6FS	0.8	
427, 400HP Normal operation			AP6FS	0.8	
V4 104, V6 122			BP7HS	0.8	BPR7HIX

Make & Model	Other	Year	Recommended Part No.	Gap (mm)	Iridium Option
JOHNSON (SEE ALSO OMC)					
153 cu. in. 110-120HPCU Series			B6ES	0.9	
89 cu. in. 88-90HPDU Series			B8S	0.8	
225 cu. in. 150-155HPHU Series			BP6S	0.9	
283 cu. in. 185HPKU Series			B6S	0.9	
1600cc 80-90HPNU Series			BP6ES	0.8	BPR6EIX
153 cu. in. 110-120HPSU Series			B6ES	0.9	

MERCRUISER INBOARD						
Model	CID/ #Cyl	Serial # Start	Serial # End	Recommended Spark Plug	Gap (mm)	Iridium Option
General Motors 4 Cyl., 98 cid						
100 Vazer	98/ L4	1A035000		BR9ES	0.9	BR9EIX
General Motors 4 Cyl., 153 cid						
110	153/ L4	1537370	2044033	BR6ES	0.9	
120	153/ L4	1666601	3825578	BR6ES	0.9	
	153/ L4	3825579	0B531853	BR6FS	0.9	
2.5L	153/ L4	0B531854	0C853255	BR6FS	0.9	
General Motors 4 Cyl., 181 cid						
140	181/ L4	2508261	3826282	BR6ES	0.9	
	181/ L4	3826283	0B450800	BR6FS	0.9	
3.0L	181/ L4	0B450801	0C856558	BR6FS	0.9	
	181/ L4	0C856559	0D504541	BR6FS	0.9	
	181/ L4	0C856559	0D504541	BR6FS	0.9	
	181/ L4	0D504542	0F603999	BPR6EFS	0.9	BPR6EFIX-10
	181/ L4	0L010042	0L340999	BPR6EFS	0.9	BPR6EFIX-10
	181/ L4	0L341000		TR5IX	1.1	
3.0L MPI	181/ L4	1A072812		TR5IX	1.1	
3.0LX	181/ L4	0C856559	0D504541	BR6FS	0.9	
	181/ L4	0C856559	0D504541	BPR6EFS	0.9	BPR6EFIX-10
	181/ L4	0D504542	0K999999	BPR6EFS	0.9	BPR6EFIX-10
General Motors 6 Cyl., 194 cid						
140	194/ L6	1538930	1725960	BR6ES	0.9	
Mercury Marine 4 Cyl., 224 cid						
165	224/ L4	0B434940	0B77451	BPR6FS	0.9	UR6IX
170	224/ L4	6916779	0B434940	BPR6FS	0.9	UR6IX
180	224/ L4	0B436391	0B775248	BPR6FS	0.9	UR6IX
190	224/ L4	6916779	0B436390	BPR6FS	0.9	UR6IX
3.7L	224/ L4	0B774252		BPR6FS	0.9	UR6IX
3.7LX	224/ L4	0B775249		BPR6FS	0.9	UR6IX
470	224/ L4	4208730	6916778	BPR6FS	0.9	UR6IX
485	224/ L4	5685394	6218036	BPR6FS	0.9	UR6IX
488	224/ L4	6170297	6916778	BPR6FS	0.9	UR6IX



MARINE – INBOARD RANGE

MERCURUISER INBOARD (CONT)

Model	CID/ #Cyl	Serial # Start	Serial # End	Recommended Spark Plug	Gap (mm)	Iridium Option	Model	CID/ #Cyl	Serial # Start	Serial # End	Recommended Spark Plug	Gap (mm)	Iridium Option
General Motors 6 Cyl., 230 cid							5.0L (Gen +)	305/ V-8	0L015751		TR5IX	1.1	
150	230/ L6	1666495	2048046	BR6ES	0.9		5.0L EFI (Gen +)	305/ V-8	0L012052	0M299999	TR5IX	1.1	
General Motors 6 Cyl., 250 cid							5.0L MIE (LH)	305/ V-8	0B788152	0C396832	BR6FS	0.9	
160	250/ L6	2048022	2770031	BR6ES	0.9		5.0L MIE (RH)	305/ V-8	0B788152	0C396832	BR6FS	0.9	
165	250/ L6	2770032	2771483	BR6ES	0.9		5.0L MPI	305/ V-8	0M300000		ITR4A15	1.5	
	250/ L6	2771484	5813433	BR6FS	0.9		5.0L MPI EC	305/ V-8	1A300000		ITR4A15	1.5	
General Motors 6 Cyl., 292 cid							5.0LX	305/ V-8	0B773740	0F600999	BR6FS	0.9	
200	292/ L6	2453769	2712072	BR6ES	0.9		898	305/ V-8	4762210	6218461	BR6FS	0.9	
General Motors V6, 229 cid								305/ V-8	6218462	6899057	BR6FS	0.9	
185 (4 bbl.)	229/ V-6	6330183	6919655	BR6FS	0.9		General Motors V8, 327 cid						
General Motors V6, 262 cid							225 MIE (GM)	327/ V-8	2278647	2694014	B8S	0.7	
175	262 V-6	0B527955	0B773242	BR6FS	0.9		250 MCM & MIE	327/ V-8	2314301	2639854	B8S	0.7	
185 (2 bbl.)	262 V-6	6919656	0B527954	BR6FS	0.9		General Motors V8, 350 cid						
205	262 V-6	0A331455	0B775129	BR6FS	0.9		250	350/ V-8	4768000	4908849	BR6FS	0.9	
262 Mag. (TBI)(Gen+)	262 V-6	0F803800	0K999999	TR5IX	1.1		255 MCM & MIE (GM)	350/ V-8	3258728	4767999	BR6FS	0.9	
4.3L	262 V-6	0B773243	0F000877	BR6FS	0.9		260	350/ V-8	4908850	6218461	BR6FS	0.9	
	262 V-6	0F000878	0F802999	BR6FS	1			350/ V-8	6218462	0B773304	BR6FS	0.9	
4.3L (Gen +)	262 V-6	0L010044		TR5IX	1.1		260 MIE (LH)	350/ V-8	5907058	0B788151	BR6FS	0.9	
4.3L EFI (Gen+)(TBI)	262 V-6	0L012009	0M299999	TR5IX	1.1		260 MIE (RH)	350/ V-8	5907058	0B788151	BR6FS	0.9	
4.3L MPI	262 V-6	0M300000		ITR4A15	1.5		270 MCM & MIE	350/ V-8	2851074	3385720	B8S	0.7	
4.3L MPI EC	262 V-6	1A637496		ITR4A15	1.5		280 TRS	350/ V-8	4176250	4499390	BR6FS	0.9	
4.3LH (Gen +)	262 V-6	0L010044	0M614999	TR5IX	1.1			350/ V-8	4499391	4770199	BR6FS	0.9	
4.3LX	262 V-6	0B775130	0F001219	BR6FS	0.9		300	350/ V-8	6668677	0B430367	BR6FS	0.9	
	262 V-6	0F001220	0F802999	BR6FS	1		320 EFI	350/ V-8	0A543604	0C622418	BR6FS	0.9	
4.3LX (Gen +)	262 V-6	0F803000	0K999999	TR5IX	1.1		350 Mag. Alpha	350/ V-8	0A635178	0K999999	BR6FS	0.9	
4.3LXH (Gen +)	262 V-6	0F803000	0K999999	TR5IX	1.1		350 Mag. Alpha EFI (Gen+)	350/ V-8	0K001509	0K999999	TR5IX	1.1	
General Motors V8, 283 cid							350 Mag. Bravo MPI	350/ V-8	0F415189	0F601999	BR6FS	0.9	
190 (8 cyl.)	283/ V-8	1564539	1730903	BR6FS	0.9		350 Mag. Bravo MPI (Gen+)	350/ V-8	0F602000	0K999999	TR5IX	1.1	
General Motors V8, 302 cid							350 Mag. EFI Ski	350/ V-8	0F215561	0K999999	TR5IX	1.1	
215 MCM & MIE (Ford)	302/ V-8	2781153	3563181	AR6FS	0.8		350 Mag. MPI (Gen+)	350/ V-8	0L010019	0L325952	TR5IX	1.1	
	302/ V-8	2781153	3563181	AR6FS	0.8			350/ V-8	0L325953	0M299999	TR5IX	1.1	
225 MCM & MIE (Ford)	302/ V-8	3385721	4166999	AR6FS	0.8		350 Mag. MPI	350/ V-8	0M300000		ITR4A15	1.5	
888 (Ford)	302/ V-8	3108723	4887829	AR6FS	0.8		350 Mag. MPI EC	350/ V-8	1A300000		ITR4A15	1.5	
General Motors V8, 305 cid							350 Mag. MPI Horizon	350/ V-8	0M300000		ITR4A15	1.5	
198 MIE	305/ V-8	4776402	4931099	BR6FS	0.9		350 Mag. MPI Horizon MIE	350/ V-8	0L304700	0M299999	TR5IX	1.1	
200	305/ V-8	6899058	0B774444	BR6FS	0.9			350/ V-8	0M300000	1A089999	ITR4A15	1.5	
228	305/ V-8	4765100	6218461	BR6FS	0.9								
	305/ V-8	6218462	6899268	BR6FS	0.9								
228 MIE	305/ V-8	4765100	5907057	BR6FS	0.9								
230	305/ V-8	6899269	0B773739	BR6FS	0.9								
230 MIE (LH)	305/ V-8	5907058	0B788151	BR6FS	0.9								
230 MIE (RH)	305/ V-8	5907058	0B788151	BR6FS	0.9								
5.0L	305/ V-8	0B774445	0F600999	BR6FS	0.9								



MARINE – INBOARD RANGE

MERCURISER INBOARD (CONT)

Model	CID/ #Cyl	Serial # Start	Serial # End	Recommended Spark Plug	Gap (mm)	Iridium Option	Model	CID/ #Cyl	Serial # Start	Serial # End	Recommended Spark Plug	Gap (mm)	Iridium Option
350 Mag. MPI MIE (Gen+)	350/ V-8	0L002008	0L302199	TR5IX	1.1		Ford V8, 350 cid						
	350/ V-8	0L302200	0M299999	TR5IX	1.1		233 MCM & MIE (Ford)	351/ V-8	4173000	4902304	AR6FS	0.8	
350 Mag. MPI MIE	350/ V-8	0M300000	1A089999	ITR4A15	1.5		255 MIE & MCM (Ford)	351/ V-8	3258728	5907057	AR6FS	0.8	
350 Mag. MPI Ski	350/ V-8	0F350583	0F799999	BR6FS	0.9		General Motors V8, 377 cid						
350 Mag. MPI Ski (Gen+)	350/ V-8	0L002600	0L304599	TR5IX	1.1		377 Mag	377/ V-8	1A300000		ITR4A15	1.5	
	350/ V-8	0L304600	0M299999	TR5IX	1.1		377 Mag EC	377/ V-8	1A300000		ITR4A15	1.5	
350 Mag. MPI Ski	350/ V-8	0M300000		ITR4A15	1.5		377 Scorpion MCM	377/ V-8	0L416146	0M907201	TR5IX	1.1	
350 Mag. Ski	350/ V-8	0D505450	0K999999	BR6FS	0.9		377 Scorpion Ski	377/ V-8	0K000656	0L600314	TR5IX	1.1	
5.7L	350/ V-8	0B773305	0K999999	BR6FS	0.9		MX 6.2L MPI	377/ V-8	0L680003	0M299999	TR5IX	1.1	
5.7L (Gen +)	350/ V-8	0L010037		TR5IX	1.1			377/ V-8	0M300000	1A299999	ITR4A15	1.5	
5.7L EFI	350/ V-8	0F225560	0K999999	BR6FS	0.9		MX 6.2L MPI Horizon	377/ V-8	0M300000		ITR4A15	1.5	
5.7L EFI (Gen +)	350/ V-8	0L010035	0M299999	TR5IX	1.1		MX 6.2L MPI Horizon MIE	377/ V-8	0M300000		ITR4A15	1.5	
5.7L EFI MIE (Gen+)	350/ V-8	0K040300	0K999999	TR5IX	1.1		MX 6.2L MPI MIE	377/ V-8	0L670000	0M299999	TR5IX	1.1	
5.7L MIE (LH)	350/ V-8	0B788152	0F024999	BR6FS	0.9			377/ V-8	0M300000		ITR4A15	1.5	
5.7L MIE (RH)	350/ V-8	0B788152	0F024999	BR6FS	0.9		MX 6.2L MPI MIE EC	377/ V-8	1A090000		ITR4A15	1.5	
5.7L MIE	350/ V-8	0F025000	0K999999	BR6FS	0.9		MX 6.2L MPI Ski	377/ V-8	0M317000		ITR4A15	1.5	
5.7L MIE (Gen+)	350/ V-8	0L002003		TR5IX	1.1		MX 6.2L Blk Scorpion Ski	377/ V-8	0L670015	0M391599	TR5IX	1.1	
5.7L MPI Horizon MIE	350/ V-8	1A090000		ITR4A15	1.5		MX 6.2L Blk Scorpion Ski	377/ V-8	0M391750	0W698432	ITR4A15	1.5	
5.7L MPI MIE	350/ V-8	1A090000		ITR4A15	1.5		Scorpion 377	377/ V-8	0W698433		ITR4A15	1.5	
5.7L MPI MIE EC	350/ V-8	1A090000		ITR4A15	1.5		Scorpion 377 HO EC	377/ V-8	1A091488		ITR4A15	1.5	
5.7L MPI Tow Sports	350/ V-8	1A090000		ITR4A15	1.5		General Motors V8, 427 cid						
5.7L MPI Tow Sports EC	350/ V-8	1A090000		ITR4A15	1.5		325 MCM & MIE	427/ V-8	2278747		R5673-8	0.9	
5.7L Ski	350/ V-8	0A338553	0F775199	BR6FS	0.9		General Motors V8, 454 cid						
	350/ V-8	0B514627	0K999999	BR6FS	0.9		330 MCM & MIE	454/ V-8	4623115	6083144	BR6FS	0.9	
	350/ V-8	0L002005		TR5IX	1.1			454/ V-8	4623115	6083144	R5673-8	0.9	
5.7LX	350/ V-8	0F601000	0K999999	BR6FS	0.9		330	454/ V-8	6083145	0B816540	BR6FS	0.9	
5.7LX Bravo EFI (Gen +)	350/ V-8	0F800300	0K999999	TR5IX	1.1		340 MIE	454/ V-8	5889914	0B788365	BR6FS	0.9	
5.7LX EFI	350/ V-8	0F752400	0K999999	BR6FS	0.9		350 MIE	454/ V-8	3780450	4623109	R5673-8	0.9	
Black Scorpion Ski (Gen+)	350/ V-8	0F800000	0M391599	TR5IX	1.1		370 TRS	454/ V-8	4179554	6721527	R5673-8	0.9	
	350/ V-8	0M391600	0W698432	ITR4A15	1.5			454/ V-8	4883520	6721527	BR6FS	0.9	
								454/ V-8	6721528	0B714586	BR6FS	0.9	
350/ V-8	0M391600	0W698432	ITR4A15	1.5		400 TRS	454/ V-8	5668232	0B457644	R5673-8	0.9		
Scorpion 350	350/ V-8	0W698433		ITR4A15	1.5			454/ V-8	5668232	0B457644	BR6FS	0.9	
Scorpion 350 EC	350/ V-8	0W698433		ITR4A15	1.5		420	454/ V-8	0A398941	0B622418	BR6FS	0.9	
							425	454/ V-8	0B622419	0D937011	BR6FS	0.9	
							440 TRS	454/ V-8	6181070	0B485220	R5673-8	0.9	
								454/ V-8	6181070	0B485220	BR6FS	0.9	

MERCURUISER INBOARD (CONT)

Model	CID/ #Cyl	Serial # Start	Serial # End	Recommended Spark Plug	Gap (mm)	Iridium Option
450	454/ V-8	0F347100	0F347277	BR6FS	0.9	
454 Mag. Alpha	454/ V-8	0A631894	0B785148	BR6FS	0.9	
454 Mag. Bravo	454/ V-8	0B721206	0K999999	BR6FS	0.9	
454 Mag. EFI	454/ V-8	0F115700	0F802349	BR6FS	0.9	
454 Mag. EFI Ski	454/ V-8	0F215800	0F820099	BR6FS	0.9	
454 Mag. MPI	454/ V-8	0F802350	0M024999	BR6FS	1	
454 Mag. MPI Horizon MIE	454/ V-8	0L002200	0L674000	BR6FVX	1	
454 Mag. MPI Ski	454/ V-8	0F820100	0K999999	BR6FS	1	
525 SC	454/ V-8	0D456000	0L415623	BR6FS	0.9	
7.4L Bravo	454/ V-8	0B771113	0K999999	BR6FS	0.9	
7.4L EFI MIE	454/ V-8	0F874815	0K999999	BR6FS	0.9	
7.4L MIE	454/ V-8	5889914	0K999999	BR6FS	0.9	
7.4L MPI (L29)	454/ V-8	0L010003	0M024330	BPR6EFS	1.1	BPR6EFIX-10
7.4L MPI MIE	454/ V-8	0F563052	0K999999	BR6FS	0.9	
7.4L MPI MIE (L29)	454/ V-8	0L002006	0L674613	BPR6EFS	1.1	BPR6EFIX-10
7.4LX Bravo EFI	454/ V-8	0F820000	0K999999	BR6FS	0.9	
7.4LX Bravo MPI	454/ V-8	0F602010	0K999999	BR6FS	0.9	
General Motors V8, 482 cid						
460 TRS	482/ V-8	6180970	6181046	R5673-8	0.9	
General Motors V8, 496 cid						
496 Mag & HO	496/ V-8	0M025000		PZTR5A-15	1.5	
496 Mag & HO EC	496/ V-8	1A066166		PZTR5A-15	1.5	
8.1S & HO MIE	496/ V-8	0M026000		PZTR5A-15	1.5	
8.1S & HO MIE EC	496/ V-8	0W697154		PZTR5A-15	1.5	
General Motors V8, 502 cid						
500	502/ V-8	0F213293	0L001772	BR6FS	0.9	
500 (Gen +)	502/ V-8	0L414639	0L601036	BR6FS	0.9	
500 EFI	502/ V-8	0L001477		BR6FS	0.9	
502 Mag.	502/ V-8	0C878221	0F114528	BR6FS	0.9	
502 Mag. EFI	502/ V-8	0D840650	0F802599	BR6FS	0.9	
502 Mag. MPI	502/ V-8	0F802600	0M024999	BR6FS	1	
525 EFI	502/ V-8	0M900146		BPR6ES	0.9	BPR6EIX
575 SCi	502/ V-8	0L306696	0M950526	R5673-8	1	
600 SC	502/ V-8	0D456489	0D763875	BR6FS	0.9	
	502/ V-8	0D763876	0F877642	R5673-8	0.9	
8.2L Mag	502/ V-8	1A351597		BPR6ES	0.9	BPR6EIX
8.2L Mag EC	502/ V-8	1A350340		BPR6ES	0.9	BPR6EIX
8.2L MIE	502/ V-8	0C878221	0F819619	BR6FS	0.9	
	502/ V-8	1A350802		BPR6ES	0.9	BPR6EIX

Model	CID/ #Cyl	Serial # Start	Serial # End	Recommended Spark Plug	Gap (mm)	Iridium Option
8.2L MIE EC	502/ V-8	1A350802		BPR6ES	0.9	BPR6EIX
8.2L MPI MIE	502/ V-8	0F819620	0L674200	BR6FS	1	
General Motors V8, 540 cid						
500 Bulldog	540/ V-8	0C577003	0F745405	BR6FS	0.9	
	540/ V-8	0K000248	0M050281	BR6FS	1	
575	540/ V-8	0A677429	0D763716	R5673-8	0.9	
General Motors V8, 572 cid						
800SC	572/ V-8	0D763836	0F877725	R5673-8	0.9	
	572/ V-8	0K000223		R5673-8	1	

Make & Model	Other	Year	Recommended Part No.	Gap (mm)	Iridium Option
OMC					
Jet Drive					
Turbojet 90			BZ7HS-10	0.8	
Turbojet 115			BZ7HS-10	0.8	
Sea Drive					
1.6L	115-SD	1985-91	BZ7HS-10	0.8	
1.8L	140-SD	1985-91	BZ7HS-10	0.8	
2.0L	140-SD	1985-91	BZ7HS-10	0.8	
2.5L		1981-84	BUHXW-1	1.3	
2.6L	190-SD	1985-88	BUHXW-1	1.3	
2.7L	225-SD	1987	BZ7HS-10	0.8	
3.0L	225-SD	1985-91	BZ7HS-10	0.8	
3.6L	275-SD	1981-87	BZ7HS-10	0.8	
4.0L	300-SD	1985-91	BZ7HS-10	0.8	
Sail Drive					
15S10G		1977-84	BPR6HS	1.1	BPR6HIX
15S10S		1977-84	BPR6HS	1.1	BPR6HIX
15S11C		1977-84	BPR6HS	1.1	BPR6HIX
15S13A		1977-84	BPR6HS	1.1	BPR6HIX
15S14M		1977-84	BPR6HS	1.1	BPR6HIX
Inboard					
All Models		1974-82	BPR6FS	0.9	UR6IX
AJ	(14mm Head, 3/8" Rch)		BP6S	0.9	
	(14mm Head, Taper Seat)		BPR6FS	0.9	UR6IX
AT	(14mm Head, 3/8" Rch)		BP6S	0.9	
	(14mm Head, Taper Seat)		BPR6FS	0.9	UR6IX
TJ	(14mm Head, 3/8" Rch)		BP6S	0.9	
	(14mm Head, Taper Seat)		BPR6FS	0.9	UR6IX



MARINE – INBOARD RANGE

Make & Model	Other	Year	Recommended Part No.	Gap (mm)	Iridium Option
OMC (CONT)					
Inboard (cont)					
TT	(14mm Head, 3/8" Rch)		BP6S	0.9	
	(14mm Head, Taper Seat)		BPR6FS	0.9	UR6IX
Stern Drive All Models					
(14mm Head, Taper Seat)		1973-85	BPR6FS	0.9	UR6IX
(14mm Head, 3/4" Rch)		1973-74	B6ES	0.9	
(18mm Head, Taper Seat)		1974	AR6FS	0.8	
CU Series			B6ES	0.9	
DU Series			B8S	0.8	
GU Series			B6ES	0.9	
HU Series			BP6S	0.9	
JU			BR6FS	0.9	
KU Series			B6S	0.9	
LU Series			B6ES	0.9	
Model 480			B8S	0.8	
NU Series			BP6ES	0.7	BPR6EIX
SU Series			B6ES	0.9	
TU-14			BP6S	0.9	
TU-15			BP6S	0.9	
TU-16			BP6S	0.9	
TU-17 and up			B6S	0.9	
TU-20			BR6FS	0.9	
TU-21			BR6FS	0.9	
VU Series			B6ES	0.9	
WU			BR6FS	0.9	
XU-20C			BR6FS	0.9	
XU20S			B6S	0.9	
Stinger Models		1978-86	BR5FS	0.9	
Stinger 4.3L Models		1978-86	BR5FS	0.9	
2.3L	Cobra	1987-90	BPR5EFS	0.9	TR5IX
3.0L	Cobra	1993-94	BPR5EFS	1.1	TR5IX
	Cobra	1987-92	BPR5FS	1.1	UR5IX
	Cobra HO	1990-95	BPR5EFS	1.1	TR5IX
4.3L	Cobra	1986-95	BPR5FS	0.9	UR5IX
	Cobra HO	1993-94	BPR5FS	1.1	UR5IX
	Cobra HO	1990-91	BPR5FS	0.9	UR5IX
5.0L	Cobra (Carb)	1986-95	BPR5FS	0.9	UR5IX
	Cobra (Carb) HO	1989-95	BPR5FS	0.9	UR5IX
	Cobra EFI	1993-95	BPR5EFS	1.1	TR5IX
5.7L	King Cobra	1986-92	BPR5FS	0.9	UR5IX
	Cobra	1986-92	BPR5FS	0.9	UR5IX
	K	1993-95	BPR5FS	1.1	UR5IX
5.8L	King Cobra EFI HO	1993-95	BPR5EFS	1.1	TR5IX

Make & Model	Other	Year	Recommended Part No.	Gap (mm)	Iridium Option
5.8L	Cobra EFI	1992-95	BPR5EFS	1.1	TR5IX
	Cobra (Carb)	1989-95	BPR5FS	0.9	UR5IX
7.4L	King Cobra (Carb)	1995	BPR5FS	1.1	UR5IX
	King Cobra EFI	1995	BPR5FS	1.1	UR5IX
	Cobra (Carb)	1990-94	BPR5FS	1.1	UR5IX
	Cobra (Carb) HO	1991-93	BPR5FS	1.1	UR5IX
7.5L	Cobra	1986-90	BPR5FS	0.9	UR5IX
8.2L	King Cobra	1992-94	BPR5FS	1.1	UR5IX
PCM					
Model 150, 200, 220			BR6FS	0.9	
Model 230, 250, 280, 350			BR6FS	0.9	
302 cu.in.18mm Heads			AR6FS	0.8	
302 cu.in.14mm Heads			BR6FS	0.9	
305, 350, 454 cu.in.			BR6FS	0.9	
351, 460 cu.in.18mm Heads			AR6FS	0.8	
351, 460 cu.in.14mm Heads			BR6FS	0.9	
ROLLS-ROYCE					
LM841			B5ES	0.9	
V-8 Engine			B5ES	0.6	
SIMPLEX (AUST)					
3HP			G-27	0.8	
15HP	Marine Ford Conversion		B5HS	0.8	
VOLVO-PENTA					
AQ60F			B5HS	0.9	
AQ80			B6S	0.7	
AQ90			B6HS	0.7	BR6HIX
AQ95, AQ95A			BP6HS	0.7	BPR6HIX
AQ100			BP6HS	0.7	BPR6HIX
AQ105A			BP7HS	0.7	BPR7HIX
AQ110			BP7HS	0.7	BPR7HIX
AQ115A, AQ115B			BP7HS	0.7	BPR7HIX
AQ120A, AQ120B			BP7HS	0.7	BPR7HIX
AQ125, AQ125A			BP6ES	0.7	BPR6EIX
AQ130, -A, -B, -C, -D			BP7HS	0.7	BPR7HIX
AQ131 A, B, C, D			BPR6HS	0.7	BPR6HIX
AQ140			BP7ES	0.7	BPR7EIX
AQ140A			BP6ES	0.7	BPR6EIX
AQ145, AQ145A			BP6ES	0.8	BPR6EIX
AQ150, -A, -B			BP6S	0.9	
AQ151 A, B, C			BPR6ES	0.7	BPR6EIX
AQ155A			BP6S	0.9	
AQ165A			BP7HS	0.7	BPR7HIX
AQ170, -A, -B, -C			BP7HS	0.7	BPR7HIX
AQ171 A, C			BPR6ES	0.7	BPR6EIX

Make & Model	Other	Year	Recommended Part No.	Gap (mm)	Iridium Option
VOLVO-PENTA (CONT)					
AQ175, AQ175A			BR6FS	0.7	
AQ180			B6S	0.7	
AQ190A			AR6FS	0.7	
AQ200, -A, -B, -C, -D, F			BPR6FS	0.7	UR6IX
AQ205A			BR6FS	0.7	
AQ210A # 177315 on			BPR6FS	0.7	UR6IX
AQ210A to # 177314			B6S	0.7	
AQ211A, 211/DP, 231/DP, 271/DP			BR6FS	0.7	
AQ225, -A, -B, -C, -D 305 c.i.			BPR6FS	0.7	UR6IX
AQ225 E, F			BPR6FS	0.7	UR6IX
AQ231A, B			BR6FS	0.7	
AQ240A			BPR6FS	0.7	UR6IX
AQ255B, 280A			BR6FS	0.7	
AQ225A, AQ225B			BPR6FS	0.7	UR6IX
AQ260, AQ260A, AQ260B			BR6FS	0.7	
AQ271A, B, C, D			BR6FS	0.9	
AQ280A			BR6FS	0.7	
AQ290, AQ290A			BR6FS	0.7	
AQ311, A, B			BR6FS	0.9	
430, 531			BR6FS	0.9	
500A, 501A			BR6FS	0.9	
570A, 571A, 572, 740A			BR6FS	0.9	
B16A, B16C			B6S	0.7	
B18A, B18C			B6HS	0.7	BR6HIX
BB25			B6S	0.7	
BB30B			B6HS	0.7	BR6HIX
BB30F			B5HS	0.9	
BB70			B6S	0.7	
	Sustained High Speed		B8S	0.7	
BB100, BB100A			B6HS	0.7	BR6HIX
BB115A, -B, -C			BP7HS	0.7	BPR7HIX
BB140			BP6ES	0.9	BPR6EIX
BB140A			BP8ES	0.7	BPR8EIX
BB145			BP6ES	0.9	BPR6EIX
BB145C			BP8ES	0.7	BPR8EIX
BB165A			BP7HS	0.7	BPR7HIX
BB170A, -B, C			BP7HS	0.7	BPR7HIX
BB225			BR6FS	0.9	
BB260, A, B, C			BR6FS	0.9	
C2, C5, C10, C23			AB-6	0.7	
Duoprop Series					
4.3L GIPNCA (.460" Reach)			BPR6FS	0.9	UR6IX
4.3L GIPNCS (.708" Reach)			BPR6EFS	0.9	BPR6EFIX-10
5.0L FL			BPR4FS	0.9	
5.0L Fi			TR4	0.9	TR4IX

Make & Model	Other	Year	Recommended Part No.	Gap (mm)	Iridium Option
5.0L GL Gen 1+			BPR6EFS	0.9	BPR6EFIX-10
5.0L Gi Gen 1+			BPR6EFS	0.9	BPR6EFIX-10
5.7L Gi			BPR6FS	0.9	UR6IX
5.7L GL			BR6FS	0.9	
5.7L Gli			BPR6FS	0.9	UR6IX
5.7L GS			BR6FS	0.9	
5.7L GS Gen 1+			BPR6EFS	0.9	BPR6EFIX-10
5.7L Gsi Gen 1+			BPR6EFS	0.9	BPR6EFIX-10
5.7L GXI			ITR4A15	1.5	
5.8L FL			BPR4FS	0.9	
5.8L Fsi			BPR6EFS	0.9	BPR6EFIX-10
7.4L Gi, GL			BR6FS	0.9	
7.4L Gi L29			BPR6EFS	0.9	BPR6EFIX-10
7.4L Gsi			BR6FS	0.9	
8.2L Gsi			BR6FS	0.9	
EC6, EC61			AB-6	0.7	
ED6, EF4			B6S	0.7	
F1, F11, F12, F12A			AB-6	0.7	
K1, K2, K11, K21, K22			AB-6	0.7	
L2, L4, L6, L41			AB-6	0.7	
M1, M2, M4			AB-2	0.7	
MB2			DR5HS	0.7	
MB10, -A			BP6HS	0.7	BPR6HIX
MB16A			B6S	0.7	
MB18F			B5HS	0.7	
MB20A			BP6HS	0.7	BPR6HIX
MB20B, MB20C			B-4H	0.7	
MB36A, MB36B			B6S	0.7	
MB50S			DR5HS	0.7	
MB100S			BP6HS	0.7	BPR6HIX
PZ-200 1/0			BR6FS	0.9	
Kerosene Engines					
AQ60F, BB30F, MB18F			B5HS	0.9	
PJX Water Jet					
4.3L Gi (.708 Reach)			BPR6EFS	0.9	BPR6EFIX-10
4.3L GS (.708 Reach)			BPR6EFS	0.9	BPR6EFIX-10
SX Cobra Series					
3.0L GS			BPR6EFS	0.9	BPR6EFIX-10
4.3L GIPNCA (.460" Reach)			BPR6FS	0.9	UR6IX
4.3L GIPNCS (.708" Reach)			BPR6EFS	0.9	BPR6EFIX-10
5.0L FL			BPR4FS	0.9	
5.0L Fi			BPR6EFS	0.9	BPR6EFIX-10
5.0L Gi Gen 1+			BPR6EFS	0.9	BPR6EFIX-10
5.0L GL Gen 1+			BPR6EFS	0.9	BPR6EFIX-10
5.7L Gi			BPR6FS	0.9	UR6IX
5.7L GL			BR6FS	0.9	
5.7 Gli			BPR6FS	0.9	UR6IX
5.7L GS			BR6FS	0.9	



MARINE – INBOARD RANGE

Make & Model	Other	Year	Recommended Part No.	Gap (mm)	Iridium Option
VOLVO-PENTA (CONT)					
5.7L GS Gen 1+			BPR6EFS	0.9	BPR6EFI-X-10
5.7L Gsi Gen 1+			BPR6EFS	0.9	BPR6EFI-X-10
5.8L FL			BPR4FS	0.9	
5.8L Fi, Fsi			BPR6EFS	0.9	BPR6EFI-X-10
7.4L GL, Gi			BPR6FS	0.9	UR6IX
7.4L Gi L29			BPR6EFS	0.9	BPR6EFI-X-10
Inboard Series					
5.7L Gxi		2002	ITR4A15	1.5	
5.8L FL/HS1			BPR4FS	0.9	
5.8L Fsi/HS1			BPR6EFS	0.9	BPR6EFI-X-10
7.4L GI EFI			BPR6FS	0.9	UR6IX
7.4L GL, GSI			BR6FS	0.9	
8.1L Gi/Gsi		2002	BR6FS	0.9	
8.2L GXI		2002	ITR4A15	1.5	
WEST-BEND					
Shark-O-Matic			B7S	0.8	
WISCONSIN					
ABM, AEM, AKM, TFM, VH4M			AB-6	0.6	
YAMAHA					
Stern Drive Engines					
1100cc	Exciter 220	1996-98	BR8HS	0.6	BR8HIX
1200cc	Exciter 135	1998-99	BR8HS	0.6	BR8HIX
	Exciter 227	1998-99	BR8HS	0.6	BR8HIX
	LS2000	1999-02	BR8HS	0.6	BR8HIX
	LX2000	2002	BR8HS	0.6	BR8HIX
	XR1800	2000-01	BR8HS	0.6	BR8HIX
3.0L	L4 EST	1990-91	BR6FS	0.9	
4.3L	V6 1989-92		BR6FS	0.9	
5.0L	V8 1989-92		BR6FS	0.9	
5.8L	V8 1989-92		BR6FS	0.9	

IRIDIUM

PLATINUM

CERAMICS

**MARINE
PERSONAL WATERCRAFT**

FUTURE

PRECIOUS METAL

AUTOMATION

VALU

VALUE

TECH

SCIENCE

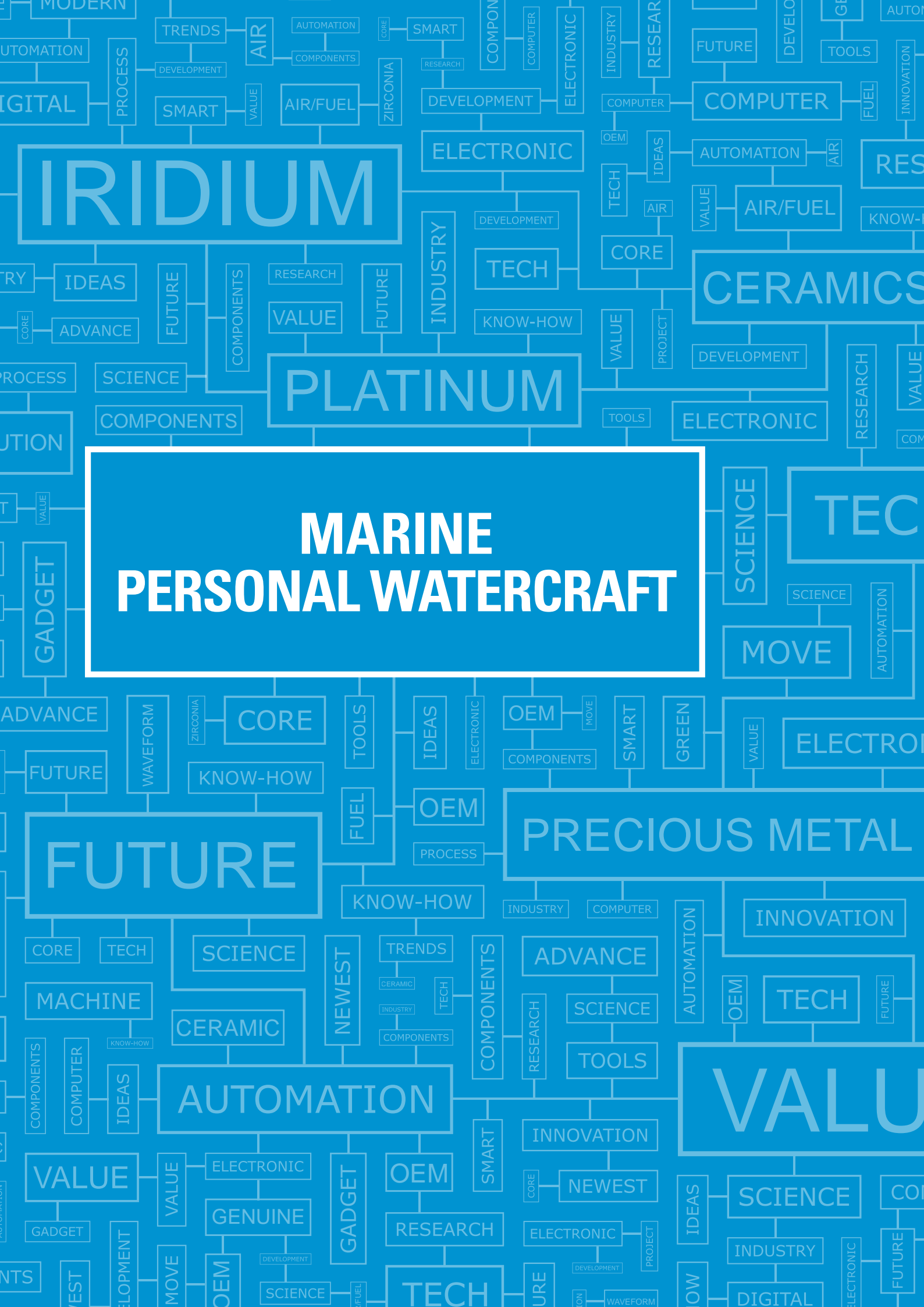



MARINE – PERSONAL WATERCRAFT



* Denotes Solid Terminal Nut and Part No. will need 'SP' added to end for ordering

Make & Model	Other	Year	Recommended Part No.	Gap (mm)	Iridium Option
ARCTIC CAT (TIGERSHARK)					
1100cc	Tigershark 1100 Li	1999	PZFR6H	0.7	
	Tigershark	1999	BR9EYA	0.7	BR9EIX
1000cc	TS1000 L	1998	BR9EYA	0.7	BR9EIX
	TS1000 R	1998-99	BR9EYA	0.7	BR9EIX
	Monte Carlo 1000	1997	BR9EYA	0.7	BR9EIX
900cc	900 Tigershark	1995	BR9ES*	0.7	BR9EIX
896cc	Monte Carlo 900	1996	BR9ES*	0.7	BR9EIX
768cc	TS770	1998-99	BR9EYA	0.7	BR9EIX
	TS770L	1998-99	BR9EYA	0.7	BR9EIX
	TS770R	1998-99	BR9EYA	0.7	BR9EIX
	TS900L	1999	BR9EYA	0.7	BR9EIX
	Daytona 770	1997	BR9EYA	0.7	BR9EIX
		1996	BR9ES*	0.7	BR9EIX
	Monte Carlo 770	1997	BR9EYA	0.7	BR9EIX
	1996	BR9ES*	0.7	BR9EIX	
644cc	Montego	1994	BR9ES*	0.7	BR9EIX
	Montego Deluxe	1994	BR9ES*	0.7	BR9EIX
	Tigershark	1993	BR9ES*	0.7	BR9EIX
639cc	TS640	1998-99	BR9EYA	0.7	BR9EIX
	TS640L	1998	BR9EYA	0.7	BR9EIX
	TS640R	1998	BR9EYA	0.7	BR9EIX
	Barracuda	1994	BR9ES*	0.7	BR9EIX
	Daytona	1995	BR9ES*	0.7	BR9EIX
		1994	BR9ES*	0.7	BR9EIX
	Monte Carlo	1994	BR9ES*	0.7	BR9EIX
	Monte Carlo 640	1997	BR9EYA	0.7	BR9EIX
		1995-96	BR9ES*	0.7	BR9EIX
	Montego	1997	BR9EYA	0.7	BR9EIX
		1995-96	BR9ES*	0.7	BR9EIX
	Montego Deluxe	1997	BR9EYA	0.7	BR9EIX
		1995-96	BR9ES*	0.7	BR9EIX
	Tigershark Daytona	1993	BR9ES*	0.7	BR9EIX
HONDA					
1235cc	Aqua Trax F-12x	2002 - 2007	IMR9D-9H	0.7	
	Aqua Trax F-12	2002 - 2007	IMR9D-9H	0.7	
1200cc	Aquatrax R-12 (ARX1200N)	2002 - 2007	IMR9D-9H	0.7	
	Aquatrax R-12X (ARX1200T)	2002 - 2007	IMR9D-9H	0.7	
KAWASAKI					
1500cc	STX-15F	2004 - 2014	CR9EK	0.7	CR9EIX
	STX	2009 - 2010	CR9EK	0.7	CR9EIX
	Ultra 250X	2007 - 2008	PMR9B	0.7	
	Ultra 260LX	2009 - 2010	PMR9B	0.7	
	Ultra 260X	2009 - 2010	PMR9B	0.7	

Make & Model	Other	Year	Recommended Part No.	Gap (mm)	Iridium Option
1500cc	Ultra 300LX	2011 - 2013	PMR9B	0.7	
	Ultra 300X	2011 - 2013	PMR9B	0.7	
	Ultra 310LX	2014	PMR9B	0.7	
	Ultra 310R	2014	PMR9B	0.7	
	Ultra 310X	2014	PMR9B	0.7	
	Ultra LX	2007 - 2014	CR9EK	0.7	CR9EIX
1200cc	1200 STX-R	2002 - 2005	BR9ES*	0.6	BR9EIX
	STX-12F	2003 - 2007	CR9EK	0.7	CR9EIX
	Ultra 150 (JH1200-A)	1999	R6918C-9	0.6	
	Ultra 150 (JH1200-A)	2000-02	BR9ES*	0.6	BR9EIX
	Ultra 150 (JH1200-B)	2003-05	BR9ES*	0.6	BR9EIX
1100cc	ZXi (JH1100-A)	1996-03	BR9ES*	0.8	BR9EIX
	Ultra 130 DI (JH1100-B)	2001-04	PZFR7G-G	0.8	
	STX (JT1100-A)	1997	BR9ES*	0.8	BR9EIX
	STX (JT1100-B)	1998-99	BR8ES*	0.8	BR8EIX
	STX (JT1100-C)	2000	PZFR7G-G	0.8	
	STX DI (JT1100-F)	2001-02	PZFR7G-G	0.8	
	STX DI (JT1100-G)	2003	PZFR7G-G	0.8	
900cc	SXi (JH900-A)	1995-97	BR9ES*	0.8	BR9EIX
	900 STX	1997 - 2006	BR9ES*	0.8	BR9EIX
	STS (JT900-B)	2001-02	BR9ES*	0.8	BR9EIX
800cc	800 SX-R (JS800-A)	2003 - 2011	BR8ES*	0.8	BR8EIX
780cc	X-2	2007	BR8ES*	0.8	BR8EIX
750cc	Super Sport (JH750-A)	1992-94	BR8ES*	0.8	BR8EIX
	Super Sport Xi (JH750-B)	1993-95	BR8ES*	0.8	BR8EIX
	ZXi (JH750-C)	1995-97	BR8ES*	0.8	BR8EIX
	XiR (JH750-D)	1994	BR8ES*	0.8	BR8EIX
	Super Sport (JH750-E)	1996-97	BR8ES*	0.8	BR8EIX
	Super Sport Xi (JH750-F)	1996-97	BR8ES*	0.8	BR8EIX
	Super Sport Xi (JH 750-G)	1998-99	BR8ES*	0.8	BR8EIX
	750SX (JS750-A)	1992-94	BR8ES*	0.8	BR8EIX
	SXi (JS750-B)	1995-97	BR8ES*	0.8	BR8EIX
	Sxi Pro (JS750-C)	1998-02	BR8ES*	0.8	BR8EIX
	ST (JT750-A)	1994	BR8ES*	0.8	BR8EIX
	STS (JT750-B)	1995-97	BR8ES*	0.8	BR8EIX
	STS (JT750-C)	1998-99	BR8ES*	0.8	BR8EIX
650cc	Jet Mate (JB650)	1989-92	BR7ES	0.8	BR7EIX
	X2 (JF650-A)	1986-95	BR7ES	0.8	BR7EIX
	TS (JF650-B)	1989-96	BR7ES	0.8	BR7EIX
	SC (JL650)	1991-95	BR7ES	0.8	BR7EIX
	650SX (JS650)	1991-95	BR7ES	0.8	BR7EIX
	650SX (JS650)	1987-90	B7ES	0.8	BR7EIX
550cc	550SX (JS550)	1982-95	BR8ES*	0.8	BR8EIX
440cc	440SX (JS440)	1976-92	BR7ES	0.8	BR7EIX
400cc	400SX (JS400)	1974-75	B7ES	0.6	BR7EIX
300cc	300SX (JS300)	1986-91	BR7ES	0.8	BR7EIX

* Denotes Solid Terminal Nut and Part No. will need 'SP' added to end for ordering

Make & Model	Other	Year	Recommended Part No.	Gap (mm)	Iridium Option
POLARIS					
1200cc	Virage Txi	2001-04	PZFR6H	0.8	
	Pro 1200	2000-01	BPR8ES	0.7	BPR8EIX
	SLX	2000-01	BPR8ES	0.7	BPR8EIX
	Virage TX	2000-01	BR9ES*	0.7	BR9EIX
1165cc	Genesis W120-99TCSP-01A3/A4	1999-01	BR9ES*	0.7	BR9EIX
	Genesis W/Ficht Fuel Inj W120-99 DF1-01	1999-04	PZFR6H	0.8	
1051cc	SLTX W105-99 TCSP-05	1999	BPR8ES	0.8	BPR8EIX
	SLX W105-99 TCSP-05	1999	BPR8ES	0.8	BPR8EIX
1050cc	SLTX 1050 WC105TCSP-03	1996-98	BPR8ES	0.8	BPR8EIX
	SL 1050 WC105TCSP-02	1997-98	BPR8ES	0.8	BPR8EIX
890cc	SL 900 WC90TCSP-01	1996-97	BPR8ES	0.7	BPR8EIX
800cc	Virage i	2002	PZFR6H	0.8	
780cc	SL 780 EC78PWE-03	1996-97	BPR8ES	0.7	BPR8EIX
	SLT 780 EC78PWE-03	1996-97	BPR8ES	0.7	BPR8EIX
	SLX 780 EC78PWR-01	1996-97	BPR8ES	0.7	BPR8EIX
779cc	SLX Pro 785 EC782PWE01	1998-00	BR9ES*	0.7	BR9EIX
777cc	Octane	2002-03	BR9ES*	0.7	BR9EIX
	Virage i	2002-04	PZFR6H	0.8	
750cc	MSX110	2004	BKR7E	0.8	BKR7EIX
	MSX150	2004	BKR7E	0.8	BKR7EIX
	SL 750 EC75PW-03	1994-95	BPR7ES	0.7	BPR7EIX
	SLT 750 EC75PW-03	1995	BPR7ES	0.7	BPR7EIX
701cc	SLH W70-99 DCSP-01A2	1999-01	BPR8ES	0.7	BPR8EIX
	SLTH W70-99 DCSP-01A1	1999	BPR8ES	0.7	BPR8EIX
700cc	Virage	2000-04	BPR8ES	0.7	BPR8EIX
	Hurricane WC70DCSP-04	1997	BPR8ES	0.7	BPR8EIX
	Hurricane WC70DCSP-03	1996	BPR8ES	0.7	BPR8EIX
	Freedom	2002-03	BPR8ES	0.7	BPR8EIX
	SL 700DLX WC70DCSP-02	1996-98	BPR7ES	0.7	BPR7EIX
	SL 700 WC70DCSP-01	1997-98	BPR8ES	0.7	BPR8EIX
650cc	SL 650 EC65PW-02	1994-95	BPR7ES	0.7	BPR7EIX

SEA-DOO (BOMBARDIER)

1500 cc	GTI	2006 - 2007	DCPR8E	0.7	DCPR8EIX
	GTI 130	2007 - 2014	DCPR8E	0.7	DCPR8EIX
	GTI SE 130	2008 - 2014	DCPR8E	0.7	DCPR8EIX
	GTI SE 155	2008 - 2014	DCPR8E	0.7	DCPR8EIX
	GTI LTD 155	2011 - 2014	DCPR8E	0.7	DCPR8EIX
	GTR 215	2012 - 2014	DCPR8E	0.7	DCPR8EIX
	GTS 130	2011 - 2014	DCPR8E	0.7	DCPR8EIX
	GTX 155	2008 - 2014	DCPR8E	0.7	DCPR8EIX
	GTX 215	2008 - 2014	DCPR8E	0.7	DCPR8EIX

1500 cc	GTX 4-TEC	2002 - 2007	DCPR8E	0.7	DCPR8EIX	
	GTX 4-TEC Wake	2003 - 2007	DCPR8E	0.7	DCPR8EIX	
	GTX LTD iS 255	2009	DCPR8E	0.7	DCPR8EIX	
	GTX LTD iS 260	2010 - 2014	DCPR8E	0.7	DCPR8EIX	
	GTX S 155	2012 - 2014	DCPR8E	0.7	DCPR8EIX	
	RXP	2004 - 2007	DCPR8E	0.7	DCPR8EIX	
	RXP 155	2008	DCPR8E	0.7	DCPR8EIX	
	RXP 215	2008 - 2009	DCPR8E	0.7	DCPR8EIX	
	RXP-X 255	2008 - 2011	DCPR8E	0.7	DCPR8EIX	
	RXP-X 255 RS	2009 - 2011	DCPR8E	0.7	DCPR8EIX	
	RXP-X 260	2012 - 2014	DCPR8E	0.7	DCPR8EIX	
	RXP-X 260 RS	2012 - 2014	DCPR8E	0.7	DCPR8EIX	
	RXT	2005 - 2007	DCPR8E	0.7	DCPR8EIX	
	RXT 215	2008 - 2010	DCPR8E	0.7	DCPR8EIX	
	RXT 260	2011 - 2014	DCPR8E	0.7	DCPR8EIX	
	RXT 260 iS	2010 - 2012	DCPR8E	0.7	DCPR8EIX	
	RXT 260 RS	2011 - 2014	DCPR8E	0.7	DCPR8EIX	
	RXT-X 255	2008 - 2009	DCPR8E	0.7	DCPR8EIX	
	RXT-X 255 RS	2009	DCPR8E	0.7	DCPR8EIX	
	RXT-X 260	2010 - 2014	DCPR8E	0.7	DCPR8EIX	
	RXT-X 260 RS	2010 - 2014	DCPR8E	0.7	DCPR8EIX	
	RXT-X aS 260	2011 - 2014	DCPR8E	0.7	DCPR8EIX	
	RXT-X aS 260 RS	2011 - 2014	DCPR8E	0.7	DCPR8EIX	
	RXT-X iS 255	2009	DCPR8E	0.7	DCPR8EIX	
	Wake 155	2008 - 2014	DCPR8E	0.7	DCPR8EIX	
	Wake Pro 215	2008 - 2014	DCPR8E	0.7	DCPR8EIX	
	950 cc	3D 947 DI	2006 - 2007	ZFR4F-11	1.1	
		GSX Limited	1997 - 1999	BR8ES	0.8	BR8EIX
		GTX	1999 - 2002	BR8ES	0.8	BR8EIX
		GTX DI	2000 - 2003	ZFR4F-11	1.1	
GTX RFI		1999 - 2002	BR8ES	0.8	BR8EIX	
LRV DI		2002 - 2003	ZFR4F-11	1.1		
RX		2000 - 2002	BR8ES	0.8	BR8EIX	
RX DI		2000 - 2003	ZFR4F-11	1.1		
RXX		2001 - 2002	BR8ES	0.8	BR8EIX	
XP		1999 - 2002	BR8ES	0.8	BR8EIX	
XP DI	2003 - 2004	ZFR4F-11	1.1			



MARINE – PERSONAL WATERCRAFT

* Denotes Solid Terminal Nut and Part No. will need 'SP' added to end for ordering

Make & Model	Other	Year	Recommended Part No.	Gap (mm)	Iridium Option	
SEA-DOO (BOMBARDIER) (CONT)						
900cc	SPARK ACE 900	2014	CR8EB	0.8	CR8EIX	
	SPARK ACE 900 HO	2014	CR8EB	0.8	CR8EIX	
780 cc	3D RFI	2004 - 2005	BR8ES	0.8	BR8EIX	
	G SX	1996 - 2000	BR8ES	0.8	BR8EIX	
	GTI	2002 - 2005	BR8ES	0.8	BR8EIX	
	GTI LE	2002 - 2005	BR8ES	0.8	BR8EIX	
	GTI RFI	2003 - 2005	BR8ES	0.8	BR8EIX	
	GTX	1996 - 2000	BR8ES	0.8	BR8EIX	
	GTX RFI	1999 - 2002	BR8ES	0.8	BR8EIX	
	SPX	1997 - 1999	BR8ES	0.8	BR8EIX	
	XP	1995 - 2000	BR8ES	0.8	BR8EIX	
	720 cc	GS	1997 - 2001	BR8ES	0.8	BR8EIX
GSi		1998 - 1997	BR8ES	0.8	BR8EIX	
GTI		2004 - 2005	BR8ES-11	1.1		
GTI		1996 - 2003	BR8ES	0.8	BR8EIX	
GTS		1997 - 2001	BR8ES	0.8	BR8EIX	
HX		1995 - 1997	BR8ES	0.8	BR8EIX	
SP		1997 - 1998	BR8ES	0.8	BR8EIX	
SPX		1996 - 1997	BR8ES	0.8	BR8EIX	
650 cc		GTX	1994 - 1995	BR8ES	0.8	BR8EIX
		SPX	1994 - 1995	BR8ES	0.8	BR8EIX
	XP	1993 - 1994	BR8ES	0.8	BR8EIX	
580 cc	GT	1990 - 1991	BR7ES	0.8	BR7EIX	
	GTS	1992 - 1997	BR7ES	0.8	BR7EIX	
	GTX	1992 - 1993	BR7ES	0.8	BR7EIX	
	SP	1988 - 1996	BR7ES	0.8	BR7EIX	
	SPi	1993 - 1997	BR7ES	0.8	BR7EIX	
	SPX	to - 1993	BR7ES	0.8	BR7EIX	
	XP	1991 - 1993	BR7ES	0.8	BR7EIX	
Sport Boats						
1500 cc	Challenger	2004 - 2006	DCPR8E	0.7	DCPR8EIX	
	180 Challenger	2005 - 2012	DCPR8E	0.7	DCPR8EIX	
	210 Challenger	2010 - 2012	DCPR8E	0.7	DCPR8EIX	
	230 Challenger	2007 - 2012	DCPR8E	0.7	DCPR8EIX	

Make & Model	Other	Year	Recommended Part No.	Gap (mm)	Iridium Option
1500 cc	230 Challenger Wake	2007	DCPR8E	0.7	DCPR8EIX
	Islandia	2004 - 2009	DCPR8E	0.7	DCPR8EIX
	230 SP	2011 - 2012	DCPR8E	0.7	DCPR8EIX
	210 SP	2011 - 2012	DCPR8E	0.7	DCPR8EIX
	180 SP	2012	DCPR8E	0.7	DCPR8EIX
	Speedster Wake	2007 - 2009	DCPR8E	0.7	DCPR8EIX
	150 Speedster	2007 - 2012	DCPR8E	0.7	DCPR8EIX
	200 Speedster	2004 - 2012	DCPR8E	0.7	DCPR8EIX
	200 Speedster Wake	2006 - 2007	DCPR8E	0.7	DCPR8EIX
	210 Wake	2008 - 2012	DCPR8E	0.7	DCPR8EIX
	230 Wake	2008 - 2012	DCPR8E	0.7	DCPR8EIX
	Sportster	2004 - 2006	DCPR8E	0.7	DCPR8EIX
	185 Utopia	2004 - 2005	DCPR8E	0.7	DCPR8EIX
	205 Utopia	2004 - 2009	DCPR8E	0.7	DCPR8EIX

TIGERSHARK

SEE ARCTIC CAT

YAMAHA

Make & Model	Other	Year	Recommended Part No.	Gap (mm)	Iridium Option	
1800cc	FX Cruiser HO (FY1800A)	2008 - 2010	LFR6A	0.9		
	FX Cruiser HO (FB1800A)	2011 - 2014	LFR6A	0.9		
	FX Cruiser SHO (FX1800A)	2008 - 2010	LFR6A	0.9		
	FX Cruiser SHO (FA1800A)	2011 - 2014	LFR6A	0.9		
	FX HO (FY1800)	2009 - 2011	LFR6A	0.9		
	FX HO (FB1800)	2012	LFR6A	0.9		
	FX SHO (FX1800)	2008 - 2011	LFR6A	0.9		
	FX SHO (FA1800)	2012	LFR6A	0.9		
	VXR (VX1800A)	2011 - 2014	LFR6A	0.9		
	VXS (VX1800)	2011 - 2014	LFR6A	0.9		
	WaveRunner FX HO (FB1800)	2013 - 2014	LFR6A	0.9		
	WaveRunner FX SHO (FA1800)	2013 - 2014	LFR6A	0.9		
	WaveRunner FZR (GX1800)	2009 - 2013	LFR6A	0.9		
	WaveRunner FZR (GX1800)	2014	LFR7A	0.9	LFR7AIX	
	WaveRunner FZS (GX1800A)	2009 - 2013	LFR6A	0.9		
	WaveRunner FZS (GX1800A)	2014	LFR7A	0.9	LFR7AIX	
	1300cc	WaveRunner III GP (GP1300,R,E,F,G)	2003 - 2008	BR8ES-11	1.1	
		1200cc	WaveRunner (XA1200)	1999	BR8ES*	0.7
	WaveRunner III GP (GP1200)		1997-98	BR8HS	0.6	BR8HIX
	WaveRunner III GP (GP1200R)		2000-02	BR8ES-11	1.1	

Make & Model	Other	Year	Recommended Part No.	Gap (mm)	Iridium Option	
YAMAHA (CONT)						
1200cc (cont)	WaveRunner (SUV1200)	1999-04	BR8HS	0.6	BR8HIX	
	WaveRunner (XL1200)	1998-99	BR8HS	0.6	BR8HIX	
	WaveRunner Ltd. (XL1200)	1999-00	BR8ES-11	1.1		
	WaveRunner (XLT1200)	2001-06	BR8ES-11	1.1		
1100cc	Deluxe (VX110)	2005	CR9EB	0.8	CR9EIX	
	FX Cruiser High Output (FX1100)	2004 - 2006	CR9EB	0.8	CR9EIX	
	FX High Output (FX1100)	2004 - 2008	CR9EB	0.8	CR9EIX	
	FX160 (FX160)	2004-08	CR9EB	0.8	CR9EIX	
	Sport (VX110)	2005	CR9EB	0.8	CR9EIX	
	VX (VX1100)	2008 - 2009	CR9EB	0.8	CR9EIX	
	VX Cruiser (VX1100B)	2008 - 2014	CR9EB	0.8	CR9EIX	
	VX Deluxe (VX1100A)	2008 - 2014	CR9EB	0.8	CR9EIX	
	VX Sport (VX1100)	2007 - 2008	CR9EB	0.8	CR9EIX	
	WaveRunner VX Cruiser (VX1100A)	2007 - 2009	CR9EB	0.8	CR9EIX	
	WaveRunner VX Cruiser (VX1100B)	2007 - 2009	CR9EB	0.8	CR9EIX	
	WaveRunner VX Sport (VX1100)	2009 - 2014	CR9EB	0.8	CR9EIX	
	VX Cruiser (VX1100A-F,B-G)	2006-08	CR9EB	0.8	CR9EIX	
	WaveRaider II (RA1100)	1995-96	BR8HS	0.6	BR8HIX	
	WaveVenture (WVT1100)	1996-97	BR8HS	0.7	BR8HIX	
	1000cc	WaveRunner (FX140)	2002-08	CR9EB	0.8	CR9EIX
		WaveRunner (FX1000)	2004 - 2008	CR9EB	0.8	CR9EIX
	800cc	WaveRunner (GP800)	1998-05	BR8ES*	0.6	BR8EIX
WaveRunner (XLT800)		2002-04	BR8ES*	0.6	BR8EIX	
WaveRunner (XA800)		2004	BR8ES*	0.6	BR8EIX	
WaveRunner (XL800)		2000-01	BR8ES*	0.6	BR8EIX	
760cc	WaveRunner III GP (GP760)	1997-00	BR8HS	0.6	BR8HIX	
	WaveRaider (RA760)	1996	BR8HS	0.6	BR8HIX	
	WaveBlaster II (WB760)	1996-97	BR8HS	0.6	BR8HIX	
	WaveVenture (WVT760)	1997	BR8HS	0.6	BR8HIX	
	WaveRunner (XL760)	1998-99	BR8HS	0.6	BR8HIX	
700cc	FX1 (FX700)	1995-96	B8HS	0.7	BR8HIX	
	WaveRaider (RA700)	1994-96	BR8HS	0.6	BR8HIX	
	WaveRaider (RA700B)	1997	BR7HS	0.6	BR7HIX	
	WaveRaider Deluxe (RA700B)	1996	BR8HS	0.6	BR8HIX	
	SuperJet (SJ700)	1994-96	BR8HS	0.7	BR8HIX	
	SuperJet (SJ700)	1997-01	BR7HS	0.7	BR7HIX	
	SuperJet (SJ700)	2002-08	BR7HS	0.7	BR7HIX	
	WaveRunner SuperJet (SJ700B)	2009 - 2014	BR7HS	0.7	BR7HIX	
	Waveblaster (WB700)	1993-96	BR8HS	0.7	BR8HIX	
	Waverunner III (WRA700)	1995-97	BR8HS	0.6	BR8HIX	

Make & Model	Other	Year	Recommended Part No.	Gap (mm)	Iridium Option
700cc	Waverunner Pro VXR (WRB700)	1993-94	BR8HS	0.6	BR8HIX
	WaveVenture (WVT700)	1995-98	BR8HS	0.6	BR8HIX
	WaveRunner (XL700)	1999-04	BR8HS	0.7	BR8HIX
650cc	SuperJet (SJ650)	1990-93	B8HS	0.6	BR8HIX
	SuperJet (SJ650)	1990-93	BR8HS	0.6	BR8HIX
	WaveRunner (WR650)	1990-92	B8HS	0.6	BR8HIX
	WaveRunner III (WRA650)	1990-96	BR8HS	0.8	BR8HIX
500cc	WaveRunner VXR (WRB650)	1991-95	B8HS	0.6	BR8HIX
	WaveJammer (WJ500)	1987-90	B7HS	0.7	BR7HIX
	WaveRunner (WR500)	1987-93	B7HS	0.7	BR7HIX



NOTES

PLATINUM

DURABILITY

FUTURE

TECH

CROSS REFERENCE CHART



CROSS REFERENCE CHART SPARK PLUG

Note: NGK recommends to use the "Torch" part numbering system as a starting point when trying to cross "Chinese" manufacturing brands back to NGK.

Other Part No.	NGK Part No.	Other Part No.	NGK Part No.	Other Part No.	NGK Part No.
ABTOKOHNHBECT		997	ZGR5A	41-993	ITR4A15
A17AB-10	BP6ES	8199	BPR5FS	41F	B6HS-10
ACCEL		ACDelco		41TS	BP6FS
111	BP9ES	40TS	BP7FS	41XL	B9ES
112	BP8ES	41-2XLS	BP7ES	41XLS	BP7ES
113	BP7ES	41-4XLS	BP6ES	42-5F	B6HS
114	BP6ES	41-101	ITR4A15	42-6FS	BP6HS
115	B6ES	41-103	ILTR5B11	42F	B6HS
116	BP5ES	41-110	IZTR5B11	42FF	B6HS
117	BP4ES	41-600	BPR5EFS-13	42FS	BP6HS
123	B7S	41-601	BPR5EFS-13	42LTS	BPR6EFS
124	B6S	41-602	BKR5E	42S	BP6S
138	BP-4	41-606	BPR5EFS-13	42TS	BP6FS
141	B9ES	41-610	BKR4E-11	42XL	B8ES
142	B8ES	41-611	BKR4E-11	42XLS	BP6ES
143	B7ES	41-627	BKR4E-11	43	B6S
146	B5ES	41-628	BKR4E-11	43F	B6HS
166	B-6L	41-812	TR6IX	43FFS	BP6HS
168	B-4L	41-900	TR5IX	43FS	BP6HS
261	R5673-10	41-902	TR55IX	43N	B7ES
262	R5673-9	41-904	TR5IX	43S	BP6S
263	R5673-8	41-906	TR5IX	43TS	BP6FS
265	R5673-6	41-907	TR5IX	43XL	B7ES
272	R5674-9	41-910	TR5IX	43XLS	BP6ES
274	R5674-7	41-913	TR55IX	44	B6S
276	BPR5FS	41-928	TR5-1IX	44F	B5HS
378	APR5FS	41-929	TR55IX	44FF	B5HS
416	BCPR5EY	41-931	PTR5C-13	44FFS	BP5HS
437	BP-4	41-932	TR55IX	44N	B6ES
494	BPR7ES	41-933	ITR4A15	44NS	BP5ES
496	BPR5ES	41-936	PTR5C-13	44S	BP5S
514	TR7IX	41-937	PTR5C-13	44T	BR5FS
516	BPR5EFS	41-940	TR4IX	44TS	BP5FS
524	TR7IX	41-942	TR4IX	44XL	B6ES
526	BPR5EFS-13	41-943	TR4IX	44XLO	BP5ES
566	BR5FS	41-947	TR55IX	44XLS	BP5ES
574	R5674-7	41-948	TR4IX	45	B-4
576	BPR5FS	41-950	PTR5C-13	45F	B5HS
577	BPR4FS	41-955	PTR5A-13	45FF	B5HS
586	BPR5FS-15	41-963	PTR5C-13	45FFS	BP5HS
736	ZFR5F	41-965	PTR5A-13	45L	B-4L
761	R5671A-10	41-974	PZTR5A-15	45NS	BP5ES
762	R5671A-9	41-980	PTR5C-13	45S	BP5S
763	R5671A-8	41-983	PZTR5A-15	45TS	BP4FS
765	R5671A-7	41-985	IZTR5B11	45XL	B6ES
784	BKR7E	41-987	PTR5C-13	45XLS	BP5ES
786	BKR5E	41-988	PLTR6A-10G	46	B-4

Note: NGK recommends to use the "Torch" part numbering system as a starting point when trying to cross "Chinese" manufacturing brands back to NGK.

Other Part No.	NGK Part No.
ACDelco (CONT) 	
46F	B5HS
46FF	B5HS
46FFS	BP5HS
46N	B5ES
46S	BP5S
46TS	BP4FS
46XL	B5ES
46XLS	BP4ES
47FF	B-4H
47S	BP-4
47XL	B4ES
48	B-4
83CTS	AP6FS
83TS	AP6FS
84T	A6FS
84TS	AP5FS
85T	APR5FS
85TS	AP5FS
86TS	AP5FS
420Z	B-4H
422Z	B5HS
425Z	B6HS
426FS	BP6HS
430Z	B7HS
436T	R5673-9
436TS	R5674-9
436XLS	BP9ES
438T	R5673-8
438TS	R5674-8
438XLS	BP8ES
440T	B7FS
440XLS	BP8ES
445Z	B8HS
5613611	TR4
5613869	BPR5EFS-13
5613877	BPR4FS-15
5614283	BPR5EFS-13
5614284	BPR5EFS-13
12597464	PLTR6A-10G
25164048	PTR5C-13
25164640	TR5IX
25165715	PTR5C-13
25186682	ZFR6U-9
25332827	TR55IX
25332828	TR55IX
B4021	B6S

Other Part No.	NGK Part No.
B403	B-4
B43	B6S
B44FS	BP5HS
B44S	BP5S
B45	B-4
C41	B7S
C42-1	B6S
C42CFS	BP6HS
C42CLTS	BP6EFS
C42CXLS	BP6ES
C42LTS	BP6EFS
C42N	B7ES
C42XLS	BP5ES
C43	B6S
C43CLTS	BPR5EFS
C43CXLS	BP6ES
C43L	B-6L
C43N	B6ES
C44	B6S
C44N	B6ES
C44NS	BP5ES
C44S	BP5S
C44XL	B6ES
C45	B-4
C45L	B-4L
C46	B-4
C47	B-4
C47W	B-4
C49	B-2
C81	AB-8
C82	AB-7
C82T	A7FS
C83	AB-7
C83T	A6FS
C84T	A6FS
C85	AB-6
C85TS	AP5FS
C86	AB-6
C87	AB-6
C88	AB-2
C88L	AB-2
CF44TS	BPR4FS
CFR1CLS	BKR7E
CFR2CLS	BKR6E
CR42CFS	BPR6FS
CR42CXLS	BPR6ES
CR42N	BR7ES

Other Part No.	NGK Part No.
CR42TS	BPR5FS
CR43	BR6S
CR43CXLS	BPR6ES
CR43K	BR6S
CR43N	BR6ES
CR43S	BP6S
CR43TS	BPR5FS-11
CR43TSM	BPR5FS-11
CR44N	BR6ES
CR44NS	BPR5ES
CR44TS	BPR5FS-11
CR44TSM	BPR5FS
CR45TS	BPR4FS
CR83T	AR6FS
CS40	BM7A
CS41	BM7A
CS41T	BM7F
CS42	BM7A
CS42S	BM7A
CS42T	BM6F
CS44TA	BM6F
CS45	BM6A
CS45T	BM6F
CS49	BM4A
CSR42S	BPMR7A
CSR45	BMR6A
FR1LS	BKR6E
FR2LS	BKR6E
FR2LSK	BKR6E
FR3CLS	BKR5E
FR3CLS6	BKR5E-11
FR3LM	ZFR5A-11
FR3LS	BKR5E
FR3LS6	BKR5E-11
FR3LSJ	BKR4E-11
FR3LSK	BKR5E
FR4LE	ZFR4F-11
FR4LSJ	BKR4E-11
FR5LS	BKR5E
IC83	AB-7
LM46	B4-LM
LM49	B4-LM
LM6	B4-LM
M40FF	B9HS
M40FFX	B9HS-10
M41FF	B8HS
M41K	B8S



CROSS REFERENCE CHART SPARK PLUG

Note: NGK recommends to use the "Torch" part numbering system as a starting point when trying to cross "Chinese" manufacturing brands back to NGK.

Other Part No.	NGK Part No.	Other Part No.	NGK Part No.	Other Part No.	NGK Part No.
ACDelco (CONT)					
M42FF	B7HS	R42CXLS	BPR6ES	R44LT	BR6EF
M42K	B7S	R42F	BR6HS	R44LTS	BPR5EFS
M43FF	B6HS	R42FS	BPR6HS	R44LTS6	BPR5EFS-13
M43S	BP6S	R42LTS	BPR6EFS	R44LTS6K	BPR5EFS-13
M44B	B6S	R42LTS6	BPR5EFS-13	R44LTSM	TR4IX
M44C	B6S	R42LTSM	BPR5EFS-13	R44LTSM6	TR4IX
M44L	B-6L	R42S	BP6S	R44LTSMA	TR4
M45	B-4	R42T	BR6FS	R44N	BR6ES
M45FF	B5HS	R42TS	BPR6FS	R44NS	BPR5ES
M47	B-4	R42TSM	BPR6FS	R44NTSE	TR5-1IX
M86	AB-6	R42TX	BR6FS-15	R44S	BP5S
MB42K	B6S	R42XL	BR8ES	R44T	BR5FS
MC102F	C7HSA	R42XLS	BPR6ES	R44TS	BPR5FS
MC104F	C6HSA	R42XLSM	ZGR5C	R44TS8	BPR4FS-15
MC122F	D8HA	R43	BR6S	R44TSX	BPR5FS-15
MC124FS	D6HA	R43C	BR6S	R44XL	BR6ES
MC41	B8S	R43CFS	BPR6HS	R44XLS	BPR5ES
MC41F	B8HS	R43CNTSE	TR5-1IX	R44XLSE	ZGR5C
MC42	B8S	R43CS	BP6S	R44XLSM	ZGR5C
MC42F	B7HS	R43CT	BR6FS	R45	BR6S
MC44	B7S	R43CTS	BPR6FS	R45LS	B-4L
MR41T	R5673-8	R43CTS6	BPR6FS	R45LTS6	BPR5EFS-13
MR42K	BR6S	R43CXL	BR7ES	R45LTS6K	BPR5EFS-13
MR42LTS	BPR6EFS	R43CXLS	BPR6ES	R45LTSM	TR4
MR43LTS	BPR5EFS	R43FS	BPR6HS	R45NS	BPR5ES
MR43T	BR6FS	R43LTS	BPR6EFS	R45NSX	BPR5ES-13
MR44C	BR6S	R43LTS6	BPR5EFS-13	R45NTSE	TR5-1IX
MR44T	BR5FS	R43LTSE	TR4IX	R45S	BP5S
MR45	B-4	R43LTSM	BPR5EFS	R45T	BR5FS
R41-5TS	BPR6FS	R43LTSX	BPR6EFS-13	R45TS	BPR4FS
R41CF	BR7HS	R43N	BR7ES	R45TS8	BPR4FS-15
R41CSL	BR8ES	R43NTSE	TR5-1IX	R45TSX	BPR4FS-15
R41CXL	BR9ES	R43S	BP6S	R45XL	BR6ES
R41CXLS	BPR7ES	R43T	BR6FS	R45XLS	BPR5ES
R41F	BR9HS	R43TS	BPR6FS	R46	BR6S
R41TS	BPR6FS	R43TS6	BPR5FS-15	R46LTS	BPR5EFS
R41XL	BR9ES	R43TSK	BPR6FS	R46N	BR5ES
R42-5LTS	BPR6EFS	R43TSX	BPR6FS	R46S	BP-4
R42-5TS	BPR6FS	R43TX	BR6FS-15	R46SZ	BPR4FS-15
R42-6FS	BPR6HS	R43XL	BR7ES	R46T	BR5FS
R42CF	BR6HS	R43XLS	BPR6ES	R46TS	BPR4FS
R42CFS	BPR6HS	R44	BR6S	R46TSX	BPR4FS-15
R42CLTS	BPR6EFS	R44CF	BR5HS	R46XL	BR5ES
R42CT	BR6FS	R44CNTSE	TR5-1IX	R46XLS	BPR4ES
R42CTS	BPR6FS	R44CXL	BR6ES	R47S	BP-4
R42CXL	BR8ES	R44CXLS	BPR5ES	R83CT	AR6FS
		R44F	BR5HS	R83CTS	APR6FS

Note: NGK recommends to use the "Torch" part numbering system as a starting point when trying to cross "Chinese" manufacturing brands back to NGK.

Other Part No.	NGK Part No.
ACDelco (CONT) 	
R83T	AR6FS
R83TS	APR6FS
R84TS	APR5FS
R84TSX	APR5FS
R85T	AR6FS
R85TS	APR5FS
R86T	AR6FS
R86TS5	APR5FS
S102F	C7HSA
S104F	C6HSA
S121F	D8HA
S121XL	D8EA
S122F	D8HA
S123XL	D7EA
S124FS	D6HA
S404XLG	B10EG
S408XLG	B9EG
S40F	B9HS
S40FR	BR9HS
S40XL	B10ES
S40XLG	B9ECS
S40XLR	BR8ES
S41F	B8HS
S41FR	BR8HS
S41XL	B9ES
S41XLG	BR8ECS
S41XLR	BR9ES
S42	B7S
S42F	B7HS
S42FR	BR7HS
S42XL	B8ES
S42XLR	BR8ES
S438XLG	B8EG
S43XL	B7ES
S43XLR	BR7ES
S44	B6S
S44F	B5HS
S44XL	B6ES
S45F	B5HS
S46	B-4
S81F	AB-8
S82F	AB-8
S83F	AB-7
S85F	AB-6
SB41	B7S
SN46	B-4

Other Part No.	NGK Part No.
TC42	B8S
TC45	B6S
TC49	B-2
TC81	AB-8
TC82	AB-8
TC83	AB-7
TC85	AB-6
TC86	AB-6
V40FFK	BUHW-2
V40FFM	BUHW
V40FFS	BUH
VB40FFM	BUHXW-1
VR40FFK	BUZHW-2
VR40FFM	BUZHW
AUTOLITE 	
12	BP7FS
13	BP6FS
14	BP6FS
15	BP5FS
16	BP4FS
23	BPR6FS
24	BPR6FS
25	BPR5FS
26	BPR4FS-15
27	BPR4FS-15
32	AP7FS
33	AP6FS
34	AP6FS
35	AP5FS
36	AP5FS
37	AP5FS
44	APR6FS
45	APR5FS
46	APR5FS
50	R5672A-10
52	R5672A-8
53	BP6ES
54	BP6ES
55	BP5ES
56	BP5ES
57	BP4ES
62	BPR7ES
63	BPR6ES
64	BPR6ES
65	BPR5ES
66	BPR5ES
67	BPR4ES

Other Part No.	NGK Part No.
72	R5670-7
73	BP6S
74	BP6S
75	BP5S
76	BP5S
77	BP-4
84	BP6S
85	BP5S
86	BP-4
87	BP-4
92	R5724-10
93	R5724-9
94	BP7EFS
103	BPR6EFS
104	BPR6EFS
105	BPR5EFS
106	BPR5EFS
112	A9FS
113	A7FS
115	A6FS
117	A6FS
124	AR6FS
127	AR6FS
132	R5673-10
133	R5673-9
134	R5673-8
135	B7FS
136	BR6FS
143	BR6FS
144	BR6FS
145	BR6FS
146	BR5FS
147	BR5FS
156	AP5FS
166	APR5FS
175	BP5S
203	BPR6FS
215	B-6L
216	B-6L
217	B-4L
218	B-4L
235	BM6A
245	BMR6A
253	BM7A
254	BM6A
255	BM6A
258	BM4A



CROSS REFERENCE CHART SPARK PLUG

Note: NGK recommends to use the "Torch" part numbering system as a starting point when trying to cross "Chinese" manufacturing brands back to NGK.

Other Part No.	NGK Part No.	Other Part No.	NGK Part No.	Other Part No.	NGK Part No.
AUTOLITE (CONT)					
273	BP6HS	403	BR6ES	747	APR5FS
274	BP6HS	404	BR6ES	763	TR5-1IX
275	BP5HS	405	BR5ES	764	BPR6EFS
276	BP5HS	406	BR5ES	765	BPR5EFS
284	BPR6HS	411	B9HS	766	BPR5EFS
292	B8S	413	B7HS	767	TR5-1
294	B6S	414	B6HS	784	AR6FS
295	B-4	415	B5HS	804	AR6FS
297	B-4	416	B5HS	865	BPR5EFS
298	B-2	417	B-4H	884	BPR6EFS-13
302	BR6S	425	BR5HS	915	ZGR5C
303	BR6S	426	BR5HS	925	ZGR5C
304	BR6S	436	B-6L	935	BPR5ES
306	B-4	437	B-4L	945	BPR5ES
308	B-2	456	B4-LM	985	ZFR4F-11
312	B8S	458	B2-LM	996	B-6L
313	B7S	472	B9EFS	2272	AB-7
314	B6S	483	BR7EFS	2413	B10EGP
315	B6S	494	B-6L	2414	B10EG
316	B6S	495	B-6L	2415	B9EG
317	B-4	497	B-4L	2416	B8EG
318	B-2	515	BP5HS	2417	B7ECS
344	AR6FS	516	BP5HS	2453	BR10HIX
353	B8S	517	BP-4H	2543	TR5-1IX
354	B6S	535	B5HS	2544	TR5-1IX
355	B6S	536	B-4H	2545	TR5-1IX
356	B-4	584	AR6FS	2546	TR5-1IX
357	B-4	603	BPR6EFS-13	2554	BPM6F
358	B-2	604	BPR6EFS-13	2585	BPR5ES
363	BR6S	605	BPR6EFS-13	2592	B10ES
372	AB-8	646	BPR5FS-15	2593	B9ES
373	AB-7	664	BPR6FS	2594	B9ES
374	AB-7	665	BPR5FS-15	2611	B10ES
375	AB-6	666	BPR4FS-15	2612	B9ES
376	AB-6	667	BPR4FS-15	2613	B9ES
377	AB-6	683	BR6FS-15	2614	B8ES
378	AB-6	684	BR6FS-15	2615	B7ES
379	AB-2	685	BR6FS-15	2616	B6ES
386	AB-6	704	BPR5FS	2634	B9HS-10
393	B7ES	723	BPR6FS	2635	B8HS
394	B6ES	724	BPR6FS	2636	B7HS
395	B5ES	725	BPR5FS-11	2652	B9HS-10
396	B5ES	726	BPR4FS	2653	B7HS
397	B5ES	727	BPR4FS-11	2654	B7HS
398	B4ES	744	APR5FS	2655	B6HS
402	BR8ES	745	APR5FS	2656	B5HS
		746	APR5FS	2675	B-6L

Note: NGK recommends to use the "Torch" part numbering system as a starting point when trying to cross "Chinese" manufacturing brands back to NGK.

Other Part No.	NGK Part No.
AUTOLITE (CONT) 	
2676	B-6L
2677	B-4L
2695	AB-8
2696	AB-7
2697	AB-6
2715	D8HA
2716	D6HA
2735	D6HA
2755	D8EA
2772	AB-8
2773	AB-7
2775	AB-6
2794	C8HSA
2795	C7HSA
2796	C6HSA
2852	BUH
2872	BUHW
2892	BUHX
2954	BM7F
2956	BM6F
2974	BPM7A
2976	BPMR7A
3012	B8S
3013	B7S
3014	B6S
3017	B-4
3035	AB-6
3036	BPR4FS-15
3055	A6FS
3116	AB-6
3203	BPR6ES
3204	BPR6ES
3205	BPR5ES
3206	BPR5ES
3207	BPR5ES
3224	BP6S
3225	BP5S
3226	BP5S
3227	BP5S
3243	BPR6EFS
3244	BPR6EFS
3245	BPR5EFS
3246	BPR5EFS
3263	R5673-9
3264	B7FS
3265	BR6FS

Other Part No.	NGK Part No.
3266	BR5FS
3267	BR5FS
3286	APR6FS
3303	BPR6FS
3325	B-6L
3327	B-4L
3345	BMR7A
3364	BPR6HS
3382	BR6S
3383	BR6S
3384	BR6S
3386	BR6S
3388	BR6S
3404	AR6FS
3423	B8S
3426	BR6S
3462	BR7ES
3463	BR6ES
3464	BR6ES
3465	BR5ES
3466	BR5ES
3485	BR5HS
3486	BR5HS
3507	B-6L
3565	BPR5EFS
3586	BPR5ES-13
3604	BPR5FS-15
3605	BPR4FS-15
3606	BPR4FS-15
3607	BPR4FS-15
3624	BR6FS
3625	BR6FS-15
3666	B4-LM
3684	BR7HS
3686	BR6HS
3702	BR9ES
3703	BR9ES
3704	BR8ES
3705	BR6ES
3706	BR6ES
3724	BPR5EFS
3854	D8EA
3885	ZGR5C
3896	ZGR5C
3910	R5672A-9
3911	R5672A-8
3912	BKR7E

Other Part No.	NGK Part No.
3922	BKR7E-11
3923	BKR7ES-11
3924	BKR6E
3926	BKR5E
3931	R5671A-11
3932	R5671A-10
3933	R5671A-9
3934	R5671A-8
3935	R5671A-7
3954	D8EA
3964	DR8EA
3983	BPR4FS-15
3985	BPR5FS-15
4043	BPR6ES-11
4052	B9ES
4053	B9ES
4054	B8ES
4055	B7ES
4056	B6ES
4062	BR9ES
4063	BR9ES
4092	B7HS
4093	B7HS
4113	BP6HS
4114	BP6HS
4123	BPR6HS
4132	D8EA
4143	DR8EA
4152	DP9EA-9
4153	DP8EA-9
4162	DPR9EA-9
4163	DR8EA
4164	D7EA
4173	D8HA
4193	C7HSA
4194	CR5HSB
4203	CR7HSA
4251	BP8ES
4252	BP7ES
4253	BP6ES
4261	BPR8ES
4263	BPR6ES
4265	BPR5ES
4275	BP5S
4302	CR8E
5143	TR5-11X
5144	TR5-1



CROSS REFERENCE CHART SPARK PLUG

Note: NGK recommends to use the "Torch" part numbering system as a starting point when trying to cross "Chinese" manufacturing brands back to NGK.

Other Part No.	NGK Part No.	Other Part No.	NGK Part No.	Other Part No.	NGK Part No.
AUTOLITE (CONT)		1765058	B5ES	1765192	BR5FS
5224	BKR5E	1765067	BP5ES	1765195	BKR6E-11
AP104	TR5IX	1765070	BP6ES	1765197	BUR7EQ
AP106	TR5IX	1765073	BP6HS	1765198	PGR5A-11
AP23	UR5IX	1765075	BP7ES	1765199	BCPR7EIX
AP24	UR5IX	1765077	BP8ES	1765202	BCPR6EP-11
AP2543	TR5-1IX	1765082	BPR5ES	1765203	BUR7EQ
AP2544	TR5-1IX	1765084	BPR6ES	1765204	ZFR6A-11
AP2545	TR5-1IX	1765090	BP6ES-11	1765205	BCPR5EY
AP2546	TR5-1IX	1765095	BP5HS	1765208	BKR6ES-11
AP3923	BCPR6EIX-11	1765096	BPR5EA-L	1765209	BCP5ES
AP3924	BCPR6EIX-11	1765106	BPR6ES-11	1765210	PFR6B-11
AP403	BUR6EB-11	1765107	BPR5ES-11	1765211	ZFR5E-11
AP404	BUR6EB-11	1765111	BR7ET	1765212	BKR6EY
AP5143	TR5-1IX	1765112	BR5ES	1765214	ZFR6F-11
AP5144	TR5-1IX	1765113	BPR6HS	1765215	PGR6A-11
AP5164	TR5IX	1765116	BP5ES-11	1765216	BKR6EP-11
AP5184	TR55IX	1765117	BR6ES	1765217	BKR6EP-8
AP5243	TR55IX	1765123	BR8ES	1765218	BKR5EYA-11
AP5245	TR55IX	1765124	BR8ET	1765219	BP5EY
AP605	TR55IX	1765132	BPR4FS-15	1765221	BR8ET
AP62	BPR7EIX	1765144	BR8EQ-14	1765222	BCPR5ES
AP63	BPR6EIX	1765148	BR6EB-L-11	1765223	ZFR5A-11
AP64	BPR6EIX	1765151	BPR5EY	1765224	ZFR5F-11
AP65	BPR5EIX	1765152	BPR5EY-11	1765225	BCPR5E-11
AP66	BPR5EIX	1765153	BPR4EY	1765226	BKR6E
AP664	UR55IX	1765155	BUR6EB-11	1765227	BKR5EP-11
AP764	TR5-1IX	1765156	BPR5EP-11	1765229	BCPR7ES-11
AP765	TR5-1IX	1765159	BR8EIX	1765230	D7EA
AP766	TR5-1IX	1765160	BCPR5ES-11	1765234	BKR5E-11
AP85	XR5IX	1765161	BCPR6ES-11	1765237	PFR6G-11
AP86	XR4IX	1765163	BCP7ES	1765238	PFR6J-11
APP3924	BCPR5EP-11	1765164	BPR7ES	1765239	PFR5B-11B
APP3924-11	BKR5EP-11	1765167	BCPR5EP-11	1765240	BKR5EYA
APP64	BPR5EP-11	1765168	BR9EQ-14	1765241	BPR5FS
AR5383	R6061-10	1765170	BUR5EB-11	1765242	BR7EFS
XP5325	LF5AIX-11	1765171	BPR6EY-11	1765246	ZFR5F
XS61	BPR8EIX	1765173	ZGR5A	1765247	BKR6EIX
BECK ARNLEY		1765174	BCP6ES	1765248	PFR5C-11
1765002	B6ES	1765178	APR5FS	1765252	BKUR6ET-10
1765004	B7ES	1765179	BPR4FS	1765253	ZFR5J-11
1765006	B7HS	1765180	BPR5EFS	1765254	ZFR4F-11
1765008	B8ES	1765181	BP6ET	1765255	BUR7EQP
1765012	B9ES	1765183	BCPR5EY-11	1765256	BUR9EQP
1765045	BR8EIX	1765184	BPR6EIX	1765257	PFR6G-13
1765052	B5HS	1765186	PFR6A-11	1765258	DCPR6E

Note: NGK recommends to use the "Torch" part numbering system as a starting point when trying to cross "Chinese" manufacturing brands back to NGK.

Other Part No.	NGK Part No.
BECK ARNLEY (CONT) NGK	
1765260	BCPR6ES
1765261	TR5-1
1765262	BKR5EKU
1765263	BKR5EY
1765264	PZFR5F-11
1765265	BKR6EK
1765266	BCPR7ET
1765267	BKR5EIX-11
1765268	BPR5EFS-13
1765269	BKR5ES-11
1765273	PFR5G-11
1765274	BKUR6ET
1765276	BKR5EKB-11
1765277	PFR6B
1765280	PFR6N-11
1765281	BKR5EIX
1765282	BKR6EIX-11
1765283	BPR5EIX
1765284	PZFR5F
1765285	BKUR6ET
1765286	BCPR6EIX
1765288	TR55IX
1765289	PFR5J-11
1765290	TR5IX
1765291	BPR6EIX-11
1765292	BCPR6EIX
1765294	BR7ES
1765296	BKR5EKP-11
1765297	BKR5EKUP
1765298	BKR6EKP-11
1765299	IFR6T11
1765300	PFR5G-13E
1765301	PFR6G-13E
1765303	PFR7B
1765304	PTR5A-13
1765305	PZFR5F-11
1765306	BPR5EIX-11
1765307	BR6EF
1765308	BKR6EKUB
1765309	BUR6EFSZ
1765310	BUR6ET
BERU	
125/14/3	B5ES
125/14/3A	BP5ES
12-5DU	D7EA
14-10A	B-4H

Other Part No.	NGK Part No.
14-10B	BP4HS
14-10C	B4ES
14-10D	BP4ES
14-10E	B-4
14-10F	BP-4
14-2AS1	B9HCS
14-3A1	B8HS
14-3AU	B8HS
14-4A1	B8HS
14-4A2	B7HS
14-4AU	B7HS
14-4B2	BP7HS
14-4C1	B8ES
14-4C2	B7ES
145/14	B5HS
145/14/3	B5ES
145/14/3A	BP5ES
145/14/5	B-4
145/14/5A	BP5S
145/14/5AMX	BPM6A
145/18	AB-6
145/18K	AP5FS
145/1A	BP5HS
14-5A	B7HS
14-5B	BP7HS
14-5BU	BP7HS
14-5C	B7ES
14-5CS	B7ECS
14-5D	BP7ES
14-5D1	BP7ES
14-5DP1	BP7ES
14-5DU	BP7ES
14-5E	B7S
14-5F	BP6S
14-6B	BP6HS
14-6C	B6ES
14-6D	BP6ES
14-6D1	BP6ES
14-6DU	BP6ES
14-7A	B6HS
14-7AU	B6HS
14-7B	BP6HS
14-7BU	BP6HS
14-7C	B6ES
14-7CU	B6ES
14-7D	BP6ES
14-7DU	BP6ES

Other Part No.	NGK Part No.
14-7E	B6S
14-7F	BP6S
14-8A	B5HS
14-8B	BP5HS
14-8C	B5ES
14-8C1	B6ES
14-8D	BP5ES
14-8E	B-4
14-8F	BP5S
14-9C	B5ES
14-9D	BP5ES
14F-6DPUR021	PFR7Q
14F-7DPURX2	IFR6D10
14F-7HUR2	ZFR5P-G
14F-8DUO	BKR5E
14F-8LDUSR	BKR6EK
14FGH-7DTUR	BKUR6ET
14FGH-7DTURX	BKUR6ET-10
14FGH-8DPURX2	PFR5G-11
14FGH-8DTURXO	BKUR5ET
14GH-7DTUR	BUR6ET
14K-6D	BP6EFS
14K-7D	BP6EFS
14R-6B	BPR6HS
14R-6BU	BPR6HS
14R-6D	BPR6ES
14R-6DU	BPR6ES
14R-7B	BPR6HS
14R-7BU	BPR6HS
14R-7D	BPR6ES
14R-7DU	BPR6ES
14S-5F	BPM7A
14S-7F	BPM6A
14S-8F	BPM6A
14SR-6F	BPMR6A
14Z-3A1	B9HS
14Z-3C1	B9ES
14Z-4AU	B8HS
14Z-6A2	B6HS
14Z-7AU	B7HS
160/14/3	B6ES
175/14	B6HS
175/14/3	B6ES
175/14/3A	BP6ES
175/14/5	B6S
175/14/5A	BP6S
175/14/5AMX	BPM6A



CROSS REFERENCE CHART SPARK PLUG

Note: NGK recommends to use the "Torch" part numbering system as a starting point when trying to cross "Chinese" manufacturing brands back to NGK.

Other Part No.	NGK Part No.	Other Part No.	NGK Part No.	Other Part No.	NGK Part No.
BERU (CONT)					
175/14A	BP6HS	95/14/3A	BP4ES	DR7BC	APR6FS
175/18	AB-6	95/14/5	B-4	DR7BP	APR6FS
175/18K	AP6FS	95/14/5A	BP-4	DR8B	APR5FS
18-10A	AB-6	95/14A	BP4HS	DR8BC	APR5FS
18-12B	AB-2	95/18	AB-6	DR8BP	APR5FS
18-4A1	AB-7	D175/14	B6HS	DR9B	APR5FS
18-4A2	AB-7	D175/14/3	B6ES	DR9BC	APR5FS
18-5A	AB-7	D200/14/3A	BP6ES	F03DAR	BKR6EK
18-5AS	AB-7	D215/14/3	BP6ES	F04DAR	BKR6EK
18-7A	AB-6	D230/14/3A	BP7ES	F2DTC	R6888A-9
18-8A	AB-6	RS16	BPR6HIX	F5DC	BCP7ES
18K-12B	AP5FS	RS18	BPR7HIX	F5DP	BCP7ES
18K-7B	AP6FS	RS33	BPR5EIX	F5DP0R	PFR7B
18K-8B	AP5FS	UXT7	PTR5A-13	F5DPOR	PFR7B
190/14Z	B6HS	BOSCH		F5DPPR302+	PFR7G
200/14/3	B6ES			F5DTC	BCPR7ET
200/14/3A	BP6ES	4417	BKR6EIX-11	F5KPP332BF	PFR7W-T
200/14/3K	BP6EFS	4418	BKR5EIX-11	F6DC	BCP6ES
200/14A	BP6HS	4419	ZFR5FIX-11	F6DC0	BCP6ES
215/14/3A	BP6ES	4448	UR5IX	F6DC0R	BKR6E
225/14	B7HS	4458	TR55IX	F6DC0	BCP6ES
225/14/3	B7ES	4459	TR55IX	F6DC0R	BKR6E
225/14/3A	BP7ES	4477	BPR6EIX	F6DCX	BCP6ES-11
225/14/3S	B7ECS	4482	LZTR4AIX-11	F6DP	BCPR6EIX
225/14/5	B7S	088811-01	R2349-11	F6DPOR	PFR6Q
225/14/5A	BP6S	D10B	AP5FS	F6DPX	BCP6ES-11
225/14/5AMX	BPM7A	D10BC	AP5FS	F6DSR	BKR6EIX
225/14A	BP7HS	D6B	AP6FS	F6DTC	BCPR6ET
225/18	AB-7	D6BC	AP6FS	F6KPP332S	PFR7S8EG
225/18S	AB-7	D6BP	AP6FS	F6LTCR	BKUR6ET-10
230/14/3A	BP7ES	D7A	A6FS	F7DC	BCP6ES
235/14/3P	BP7ES	D7AC	A6FS	F7DC0R	BKR6E
240/14	B7HS	D7B	AP6FS	F7DC0	BCP6ES
240/14/3	B7ES	D7BC	AP6FS	F7DC0R	BKR6E
240/14A	BP7HS	D7BP	AP6FS	F7DCX	BKR6E-11
240/18	AB-7	D8A	APR5FS	F7DP	BCP6ES
260/14	B8HS	D8AC	APR5FS	F7DPER	PFR6G-11
260/14/3	B8ES	D8B	AP5FS	F7DTC	BCPR6ET
260/18	AB-8	D8BC	AP5FS	F7HER2	ZFR5P-G
280/14	B8HS	D8BP	AP5FS	F7HPP22	PZFR5D-11
280/14/3Z	B9ES	D9B	AP5FS	F7HPP222	PZFR5D-11
280/14Z	B9HS	D9BC	AP5FS	F7HPPRX	PZFR5D-11
310/14S	B9HCS	DR10B	APR5FS	F7KTCR	BCPR6ET
45/18	AP5FS	DR10BC	APR5FS	F7LC0R2	ZFR6F-11
95/14	B-4H	DR6B	APR6FS	F7LC0R2	ZFR6F-11
95/14/3	B4ES	DR6BC	APR6FS	F7LDCR	BKR6EK
		DR6BP	APR6FS	F7LTCR	BKUR6ET-10
		DR7B	APR6FS		

Note: NGK recommends to use the "Torch" part numbering system as a starting point when trying to cross "Chinese" manufacturing brands back to NGK.

Other Part No.	NGK Part No.
BOSCH (CONT) 	
F8DC	BCP5ES
F8DC4	BCP5ES
F8DC0	BKR5E
F8DCOR	BCPR5ES
F8DCX	BCPR5ES-11
F8DPER	BKR5EIX
F8LCR	ZFR5F
F8LCR2	ZFR5F
F8LDCR	BKR5EK
F9DC0	BCP5ES
F9LCR	ZFR4F-11
FGR5KQE0	BKR7EQUP
FGR6DQE0	BKR6EQUA
FGR6KQC	BKR6EQUP
FGR7DQE0	BKR6EQUA
FGR7DQP	BKR6EQUP
FGR8KQE	BKR5EKUP
FLR8LD+U	BKR5EK
FLR8LDCU	BKR6EK
FLR9LTE	BKR5EK
FQR8DE	BKR6EZ
FQR8LE2	ZFR5F
FQR8LEU2	ZFR5F
FR10DCX	BKR4E-11
FR10DX	BKR4E-11
FR5DC	BKR7E
FR5DCX	BKR7E-11
FR5DP	BKR7E
FR5DTC	BCPR7ET
FR5LDC	BKR7EKC
FR6D+	BKR6E
FR6D133	IFR6J11
FR6DC	BKR6E
FR6DC+	BKR6E
FR6DC2	BKR6E
FR6DCP	BKR6EIX
FR6DCX	BKR6E-11
FR6DDC	BKR7EKC-N
FR6DP	BKR6E
FR6DPP332	PFR6B
FR6DPX	BKR6E-11
FR6DTC	BCPR6ET
FR6DTCW	BCPR6ET
FR6K1133X	BKR6EIX-11
FR6KDC	BKR6EKC
FR6KDC+	BKR6EKC

Other Part No.	NGK Part No.
FR6KDE0	BKR6EKE
FR6KPP332S	PFR6Q
FR6KTC	BCPR6ET
FR6LDC	BKR6EK
FR6LTC	BKUR7ET
FR7D+	BKR6E
FR7D+X	BKR6ES-11
FR7DC	BKR6E
FR7DC+	BKR6E
FR7DC0	BKR6E
FR7DC2	BKR6E
FR7DC4	BKR6E
FR7DC9	BKR6E
FR7DCX	BKR6E-11
FR7DCX+	BCPR6ES-11
FR7DE	BKR6E
FR7DII33X	BKR6EIX-11
FR7DII33X	IFR6E11
FR7DP	BKR6E
FR7DP1X	PFR6B-11
FR7DPP+	PFR6B
FR7DPP10	BKR6EIX
FR7DPP22U	PFR6N-11
FR7DPP33	PFR6Q
FR7DPX	BKR6E-11
FR7DQP	BKR6EQUP
FR7DTC	BCPR6ET
FR7HC0X	ZFR5E-11
FR7HPP332	PZFR5N-11T
FR7KC	BKR6EY
FR7KCU	BKR6EYA-11
FR7KCV	BKR6EY
FR7KCX	BKR6EY-11
FR7KDC	BKR6EKC
FR7KI30	FR6EI
FR7KII33X	ZFR6FIX-11
FR7KII33X	IFR6E11
FR7KTC	BKUR6ET-10
FR7LC2	BKR6E
FR7LCX	ZFR6F-11
FR7LCX+	ZFR6F-11
FR7LD	BKR6EK
FR7LD+	BKR6EK
FR7LDC	BKR6EKC
FR7LDC+	BKR6EKC
FR7LDU	BKR6EKC
FR7LII33X	ZFR6FIX-11

Other Part No.	NGK Part No.
FR7LII33X	IFR6E11
FR7ME	LFRA6A
FR7N1133X	LFRA6AIX-11
FR7N133	ILFR6B
FR7NPP33	ILZFR6C-11K
FR7SE	ILZFR6C-11K
FR7SI30	ILZFR6C-11K
FR8D+	BKR5E
FR8D+X	BKR5ES-11
FR8D130	BKR5EIX
FR8DC	BKR5E
FR8DC+	BKR5E
FR8DC0	BKR5E
FR8DCX	BKR5E-11
FR8DCX+	BKR5E-11
FR8DE	BKR5EZ
FR8DII33X	BKR5EIX-11
FR8DPP33	IFR5D10
FR8DPP33+	IFR5D10
FR8DPX	BKR5E-11
FR8DX	BKR5E-11
FR8HC0X	ZFR5E-11
FR8HDC	BKR5EKB-11
FR8HDC+	BKR5EKB-11
FR8HP	PZFR5F-11
FR8HP0	ZFR5E-11
FR8KC	BKR5EYA-11
FR8KC+	BKR5EYA-11
FR8KCU	BKR5EYA-11
FR8KII33X	IFR5E11
FR8KII33X	BKR5EIX-11
FR8KTC	BKUR5ET-10
FR8KTC+	BKUR5ET-10
FR8KTCR	BKUR5ET
FR8LCX	ZFR5F-11
FR8LD+U	BKR5EK
FR8LDC	BKR5EK
FR8LDC4	BKR5EK
FR8LII33X	ZFR5FIX-11
FR8LPX	PZFR5F-11
FR8LTC	BKUR5ET-10
FR8ME	LFRA5A-11
FR8MII33X	LFRA5AIX-11
FR8MII33X	ILFR5B11
FR8SC	LFRA6B
FR8SPP332	PLFR5A-11
FR9D+	BKR5E



CROSS REFERENCE CHART SPARK PLUG

Note: NGK recommends to use the "Torch" part numbering system as a starting point when trying to cross "Chinese" manufacturing brands back to NGK.

Other Part No.	NGK Part No.	Other Part No.	NGK Part No.	Other Part No.	NGK Part No.
BOSCH (CONT)					
FR9DCX	BKR4E-11	HR10BCX	BPR4FS-11	HR8DPX	TR5IX
FR9DPV	BKR5EIX-11	HR10BCY	BPR4FS-15	HR8KII33V	TR55IX
FR9HC	ZFR4F-11	HR10BCZ	BPR4FS-15	HR8KII33Y	TR55IX
FR9HCV	ZFR5A-11	HR10BX	BPR4FS-11	HR8LC0	TR5-1
FR9LCX	ZFR4F-11	HR10BY	BPR4FS-15	HR8LI33U	TR5IX
H10B	BP4FS	HR10DCX	TR4	HR8LI33U	IZTR5B11
H10BC	BP4FS	HR10HC0	TR5-1	HR8LP0	TR5-1
H10C	BP4FS	HR6B	BPR6FS	HR8LPX	TR5-1IX
H2CS	B9EFS	HR6BC	BPR6FS	HR8NPP302	PLTR6A-10G
H3CS	B8EFS	HR6BP	BPR6FS	HR9A	BR5FS
H5D	BP7EFS	HR6D	BPR6EFS	HR9AC	BR5FS
H5DC	BP7EFS	HR6D+	BPR6EFS	HR9AP	BR5FS
H5DC0	BP7EFS	HR6DC	BPR6EFS	HR9B	BPR4FS
H5DP	BP7EFS	HR6DC+	BPR6EFS	HR9BC	BPR4FS
H6B	BP6FS	HR6DP	BPR6EFS	HR9BC+	BPR4FS
H6BC	BP6FS	HR6DS	BPR6EFS	HR9BCY	BPR4FS-15
H6D	BP6EFS	HR6KII33X	TR6IX	HR9BCY+	BPR4FS-15
H6DC	BP6EFS	HR6KII33X	ITR5H13	HR9BCZ	BPR4FS-15
H6DC0	BP6EFS	HR7D+	BPR6EFS	HR9BP	BPR4FS
H6DP	BP6EFS	HR7DC	BPR6EFS	HR9BPX	BPR4FS-11
H7CC	BR6EF	HR7DC+	BPR6EFS	HR9BPY	BPR4FS-15
H7CP	BR6EF	HR7DCX	BPR6EFS	HR9BY	BPR4FS-15
H7D	BP6EFS	HR7DCY	BPR6EFS-15	HR9D	BPR5EFS
H7DC	BP6EFS	HR7DII33V	TR65IX	HR9DC	BPR5EFS
H7DC0	BP6EFS	HR7DII33V	ITR5H13	HR9DCX	BP5EFS-13
H7DCY	BP6EFS-13	HR7KII33V	TR65IX	HR9DCY	BPR5EFS-13
H7DP	BP6EFS	HR7KPP33	PTR6F-13	HR9DPX	TR5IX
H7DPY	BP6EFS-13	HR7KPP33+	PTR6F-13	HR9DPY	TR55IX
H8B	BP5FS	HR7MPP	PTR5A-13	HR9HC0	TR5-1
H8BC	BP5FS	HR7MPP+V	PTR5A-13	HR9KII33Y	TR55IX
H8BP	BP5FS	HR7MPP302	PLTR6A-10G	HR9KII33Y	ITR4A15
H8DC	BP5EFS	HR8A	BR5FS	HR9L1133X	TR4IX
H8DC0	BP5EFS	HR8AC	BR5FS	HR9LCX	TR5-1
H8DCX	BP5EFS-13	HR8AP	BR5FS	HR9LCY	TR55-1
H8DP	BP5EFS	HR8B	BPR5FS	HR9LPX	TR5-1IX
H9B	BP4FS	HR8BC	BPR5FS	HR9SII330X	LZTR4AIX-11
H9BC	BP4FS	HR8BCY	BPR5FS-15	HS5E	BM7F
H9BCY	BPR4FS-15	HR8BP	BPR5FS	HS7F	BPM6F
H9D	BP5EFS	HR8BPX	BPR5FS-11	HS8E	BM6F
H9DC	BP5EFS	HR8BPY	BPR5FS-15	M10A	AB-6
H9DC0	BP5EFS	HR8BY	BPR5FS-15	M10A0	AB-6
H9HP	BP5EFS	HR8D+	BPR5EFS	M10AC	AB-6
HR10A	BR5FS	HR8D1133X	TR5IX	M10AC0	AB-6
HR10AC	BR5FS	HR8DC	BPR5EFS	M12B	AP5FS
HR10B	BPR4FS	HR8DC+	BPR5EFS	M145T1	AB-6
HR10BC	BPR4FS	HR8DCX	BPR5EFS	M145T5	AB-6
				M175T1	AB-7

Note: NGK recommends to use the "Torch" part numbering system as a starting point when trying to cross "Chinese" manufacturing brands back to NGK.

Other Part No.	NGK Part No.	Other Part No.	NGK Part No.	Other Part No.	NGK Part No.
BOSCH (CONT)					
M175T5	AB-6	VR8SC	LZKAR7A	W175T35	BP6HS
M225T1	AB-7	VR8SC+	LZKAR7A	W175T6	BP6S
M240T1	AB-7	VR8SE	LZKAR7A	W175TR1	BR6HS
M260T1	AB-8	VR8SEW	LZKAR7A	W175TR2	BR6ES
M280T1	AB-8	W06CS	B11EGV	W175TR30	BPR6ES
M35T1	AB-2	W07CS	B10EGV	W175TR35	BPR6HS
M45T1	AB-2	W08AS	B9HVX	W175Z1	B6HS
M4A	AB-7	W08CS	B10EGV	W200T30	BP6ES
M4A1	AB-8	W10A	B-4H	W200T35	BP6HS
M4A2	AB-7	W10AC	B-4H	W200TR30	BPR6ES
M4AC	AB-7	W10C	B4ES	W215P21	BP6ES
M5A	AB-7	W10CC	B4ES	W215T30	BP6ES
M5AC	AB-7	W10D	BP4ES	W220T30	BP6ES
M7A	AB-6	W10DC	BP4ES	W225S1S	BR7HIX
M7AC	AB-7	W10E	B-4	W225S2S	BR7EIX
M8A	AB-6	W10F	BP-4	W225T1	B7HS
M8A0	AB-6	W10FC	BP-4	W225T2	B7ES
M8AC	AB-6	W125T1	B-4H	W225T3	B7S
M8AC0	AB-6	W125T2	B4ES	W225T30	BP7ES
M95T1	AB-6	W125T3	B-4	W225T35	BP7HS
M95T5	AB-6	W125T30	BP5ES	W225T7	B8HS
MA125T7	AP5FS	W125T4	B-4H	W225TR1	BR7HS
MA125TR7	APR5FS	W125T6	BP5S	W225TR2	BR7ES
MA145T7	AP5FS	W125TR2	BR5ES	W225TR30	BPR7ES
MA145TR7	APR5FS	W125TR3	BR6S	W230T30	BP7ES
MA175T1	A6FS	W125TR30	BPR5ES	W235P21	BP7ES
MA175T7	AP6FS	W125TR6	BP5S	W240M	B8HS
MA200T7	AP6FS	W12A	B-4H	W240T1	B8HS
MA225T1	A7FS	W12E	B-2	W240T2	B8ES
MA95T7	AP5FS	W145M1	B5HS	W240T3	B7S
MA95TR7	APR5FS	W145M2	B5ES	W250P21	BP7ES
U175T1	C6HSA	W145T1	B5HS	W250T1	B8HS
U250T1	C7HSA	W145T2	B5ES	W250T2	B8ES
U260T1	CR6HSA	W145T3	B6S	W250TR2	BR8ES
U3CC	C7E	W145T30	BP5ES	W255T30	BP7ES
U4AC	C6HSA	W145T35	BP5HS	W260M1	B8HS
U5AC	CR5HSA	W145T6	BP5S	W260MZ1	B8HS
U6AC	CR4HSA	W145TR2	BR5ES	W260MZ2	B9ES
UR2AS	CR8HSA	W145TR3	BR6S	W260S1S	BR8HIX
UR2CC	CR8E	W145TR30	BPR5ES	W260S2S	BR8EIX
UR3AC	CR7HSA	W145TR6	BP5S	W260T1	B8HS
UR3AS	CR7HSA	W160T2	B6ES	W260T2	B8ES
UR3CC	CR7E	W160T30	BP5ES	W260T20	B8ES
UR4AS	CR6HSA	W175T1	B6HS	W260T30	BP8ES
UR5	CR7HSA	W175T2	B6ES	W275T1	B8HS
USR4AC	CMR6H	W175T3	B6S	W275T2	B8ES
		W175T30	BP6ES	W280MZ1	B8HS



CROSS REFERENCE CHART SPARK PLUG

Note: NGK recommends to use the "Torch" part numbering system as a starting point when trying to cross "Chinese" manufacturing brands back to NGK.

Other Part No.	NGK Part No.	Other Part No.	NGK Part No.	Other Part No.	NGK Part No.
BOSCH (CONT)					
W280MZ2	B9ES	W4C	B8ES	W7A	B6HS
W280P21	BP8ES	W4C1	B8ES	W7A0	B6HS
W280S1S	BR8HIX	W4C2	B8ES	W7AC	B6HS
W280S2S	BR8EIX	W4C3	B8HS	W7A00	B6HS
W280T30	BP8ES	W4CC	B8ES	W7AP	B6HS
W2A	B9HS	W4CP	BR8EIX	W7B	BP6HS
W2AC	B9HS	W4CS	BR8EIX	W7BC	BP6HS
W2AP	B9HVX	W4DP	BP7ES	W7BP	BP6HS
W2AS	B9HVX	W4E2	B7S	W7C	B6ES
W2C	B10ES	W5A	B7HS	W7CC	B6ES
W2C0	B10ES	W5AC	B7HS	W7CC0	B6ES
W2CC	B10ES	W5AP	B7HS	W7CCX	B6ES
W2CS	B10EVX	W5AS	BR7HIX	W7CP	B6ES
W2D	BP9ES	W5B	BP7HS	W7CPX	B6ES
W300T1	B9HS	W5BC	BP7HS	W7CX	B6ES
W300T2	B9ES	W5BP	BP7HS	W7D	BP6ES
W300T30	BP9ES	W5C	B7ES	W7D0	BP6ES
W310S1S	B9HVX	W5CC	B7ES	W7DC	BP6ES
W330T1	B9HS	W5CCX	B7ES	W7DC0	BP6ES
W340S1S	B9HVX	W5CP	B7ES	W7DCR	BPR6ES
W340S2S	B10EGV	W5CPX	B7ES	W7DCX	BP6ES-11
W370S2S	B10EGV	W5CS	BR7EIX	W7DP	BP6ES
W3A	B8HS	W5D	BP7ES	W7DPX	BP6ES-11
W3A0	B8HS	W5D1	BP7ES	W7DT	BP6ET
W3AC	B8HS	W5DC	BP7ES	W7DTC	BP6ET
W3AP	B8HS	W5DC0	BP7ES	W7DX	BP6ES-11
W3AS	BR8HIX	W5DCX	BP7ES-11	W7E	B6S
W3C	B9ES	W5DP	BP7ES	W7EC	B6S
W3C0	B9ES	W5DPX	BP7ES-11	W7EP	B6S
W3CC	B9ES	W5DTC	BP6ET	W7F	BP6S
W3CP	B9ES	W5E	B7S	W7FC	BP6S
W3CS	BR9EIX	W5EC	B7S	W7LTCR	BP6ET
W3D	BP8ES	W5EP	B7S	W8A	B5HS
W3DP	BP8ES	W6AS	BR6HIX	W8A0	B5HS
W3DP0	BP8ES	W6B	BP6HS	W8AC	B5HS
W3DP2	BP8ES	W6BC	BP6HS	W8AP	B5HS
W400S2S	B11EGV	W6BP	BP6HS	W8B	BP5HS
W45T1	B-4H	W6D	BP6ES	W8BC	BP5HS
W45T3	B-4	W6D1	BP6ES	W8BP	BP5HS
W4A	B8HS	W6DC	BP6ES	W8C	B5ES
W4A1	B8HS	W6DC0	BP6ES	W8C0	B5ES
W4A2	B8HS	W6DCX	BP6ES-11	W8CC	B5ES
W4A5	B8HS	W6DP	BP6ES	W8CCX	B5ES
W4AC	B8HS	W6DP0	BPR6EIX	W8CP	B5ES
W4AP	B8HS	W6DPX	BP6ES-11	W8D	BP5ES
W4AS	BR8HIX	W6DTC	BP6ET	W8DC	BP5ES
		W6LTCR	BP6ET	W8DC0	BP5ES

Note: NGK recommends to use the "Torch" part numbering system as a starting point when trying to cross "Chinese" manufacturing brands back to NGK.

Other Part No.	NGK Part No.
BOSCH (CONT) 	
W8DCX	BP5ES-11
W8DCY	BPR5ES-13
W8DP	BP5ES
W8DPX	BP5ES-11
W8DTC	BP6ET
W8DX	BP5ES-11
W8E	B6S
W8EC	B6S
W8F	BP5S
W8FC	BP5S
W8LCR	ZGR5A
W8LDCR	BUR6ET
W8LPR	ZGR5A
W8LTCR	BP6ET
W95T1	B-4H
W95T2	B4ES
W95T3	B-4
W95T30	BP4ES
W95T6	BP-4
W95TR6	BP-4
W9A	B-4H
W9A0	B-4H
W9AC	B5HS
W9AC0	B5HS
W9C	B4ES
W9CC	B4ES
W9D	BP5ES
W9DC	BP5ES
W9DC0	BP5ES
W9DCX	BP5ES-11
W9DP	BP5ES
W9DPX	BP5ES-11
W9E	B-4
W9E0	B4-LM
W9EC	B-4
W9EC0	B4-LM
W9F	BP5S
W9FC	BP5S
W9HC	ZGR5C
W9LC	ZGR5A
WA125T30	BP5EFS
WA125T40	BP4FS
WA125TR30	BPR5EFS
WA125TR4	BR5FS
WA125TR40	BPR4FS
WA145T40	BP5FS

Other Part No.	NGK Part No.
WA145TR4	BR5FS
WA145TR40	BPR5FS
WA175T30	BP6EFS
WA200T30	BP6EFS
WA200T40	BP6FS
WA200TR30	BPR6EFS
WA200TR40	BPR6FS
WA225T30	BP7EFS
WA95T40	BP4FS
WA95TR4	BR5FS
WA95TR40	BPR4FS
WAK145T3	BM6F
WAK225T3	BM7F
WEA	BUH
WET1	BUH
WKA145T3	BM6A
WKA145T6	BPM6A
WKA145TR6	BPMR6A
WKA175T3	BM6A
WKA175T6	BPM6A
WKA200TR6	BPMR6A
WKA225T3	BM7A
WKA225T6	BPM7A
WR10A	BR4HS
WR10AC	BR4HS
WR10E	BR6S
WR10F	BP-4
WR10FC	BP-4
WR10LC	ZGR5B
WR2CC	BR10ES
WR3CC	BR9ES
WR3CS	BR9EIX
WR3CTC	BR9ET
WR4AC	BR8HS
WR4CC	BR8ES
WR4CP	BR8ES
WR5A	BR7HS
WR5AC	BR7HS
WR5C	BR7ES
WR5CC	BR7ES
WR5CP	BR7ES
WR5D	BPR7ES
WR5D+	BPR7ES
WR5DC	BPR7ES
WR5DC+	BPR7ES
WR5DP	BPR7ES
WR5DS	BPR7EIX

Other Part No.	NGK Part No.
WR6BC	BPR6HS
WR6D	BPR6ES
WR6D+	BPR6ES
WR6DC	BPR6ES
WR6DC+	BPR6ES
WR6DCX	BPR6ES-11
WR6DP	BPR6ES
WR6DPX	BPR6ES-11
WR6DS	BPR6EIX
WR7A	BR6HS
WR7AC	BR6HS
WR7B	BPR6HS
WR7B+	BPR6HS
WR7BC	BPR6HS
WR7BC+	BPR6HS
WR7BP	BPR6HS
WR7C	BR6ES
WR7CC	BR6ES
WR7CP	BR6ES
WR7D	BPR6ES
WR7D+	BPR6ES
WR7DC	BPR6ES
WR7DC+	BPR6ES
WR7DCX	BPR6ES-11
WR7DCX+	BPR6ES-11
WR7DP	BPR6ES
WR7DPX	BPR6EIX-11
WR7DS	BPR6EIX
WR7EC	BR6S
WR7F	BP6S
WR7LTCR+	BUR6ET
WR8AC	BR5HS
WR8B+	BPR5HS
WR8BC	BPR5HS
WR8C	BR5ES
WR8CC	BR5ES
WR8CP	BR5ES
WR8D	BPR5ES
WR8D+	BPR5ES
WR8DC	BPR5ES
WR8DC+	BP5ES
WR8DC0	BPR5ES
WR8DC4	BPR5ES
WR8DCX	BPR5ES-11
WR8DCX+	BPR5ES-11
WR8DP	BPR5ES
WR8DPX	BPR5ES-11



CROSS REFERENCE CHART SPARK PLUG

Note: NGK recommends to use the "Torch" part numbering system as a starting point when trying to cross "Chinese" manufacturing brands back to NGK.

Other Part No.	NGK Part No.	Other Part No.	NGK Part No.	Other Part No.	NGK Part No.
BOSCH (CONT)		WSR5F	BPMR7A	697858	BR2-LM
WR8DPY	BPR5ES-13	WSR6F	BPMR6A	711252	BPR6HS
WR8DS	BPR5EIX	WSR8E	BMR6A	790885	BPMR6F
WR8E	BR6S	WSR8F	BPMR6A	796112	BR2-LM
WR8EC	BR6S	WSR9E	BMR4A	801254	BPMR4A
WR8EP	BR6S	X260T1	D6HA	802592	BR2-LM
WR8F	BP5S	X260T2	D6EA	805015	BKR5E
WR8FC	BP5S	X300T1	D8HA	492167S	B2-LM
WR8FP	BP5S	X300T2	D9EA	5062 A&B&C	B2-LM
WR8HP	ZGR5C	X3CP0	D9EA	5066A	BKR5E
WR8LC	ZGR5A	X4CS	D8EA	BRISK	
WR8LC+	ZGR5A	X5CC	D8EA	D17Y	BKR5E
WR8LTC+	BUR5ET	X5DC	D7EA	CGI	
WR9A0	BR5HS	XR2AS	DR8HS	F6TC	BP5ES
WR9C	BR5ES	XR2CS	DR9EA	CHAMPION	
WR9CC	BR5ES	XR4AS	DR8HS	11	APR5FS
WR9D	BPR5ES	XR4CS	DR9EA	11C2	APR5FS
WR9D+	BPR5ES	XR4DC	DR8EA	11S	APR5FS
WR9DC	BPR5ES	XR5DC	DR7EA	13C2	BPR5EFS-13
WR9DC+	BPR5ES	XR6CC	DR7EA	13S	BPR5EFS-13
WR9DCX	BPR5ES-11	XR7LDC	DPR7EA-9	14C2	BP5S
WR9DCY	BPR5ES-13	Y6DC	DCPR6E	15C2	TR4
WR9DP	BPR5ES	YR5DDE	KR9CI	15S	TR4
WR9DPX	BPR5ES-11	YR5LDE	DCPR8EK	17	BPR4FS-15
WR9DS	BPR5EIX	YR6LDE	DCPR8EK	17C2	BPR4FS-15
WR9DY	BPR5ES-13	BOSNA		18	BPR4FS
WR9E	BR6S	SUPER FE65CPR	BPR5ES	18C2	BPR4FS
WR9E0	BR6S	BRIGGS & STRATTON		18S	BPR4FS
WR9EC	BR6S	29683	B2-LM	19	BPR4FS
WR9EC0	BR6S	29693	B6S	19C2	BPR4FS-15
WR9F	BP5S	293918	BMR6A	20	BPR5EFS
WR9FC	BP5S	298808	BM6A	21	APR5FS
WR9FP	BP5S	298809	B2-LM	21S	APR5FS
WR9H	ZGR5C	391919	BR2-LM	22	APR5FS
WR9HC	ZGR5C	392588	BR2-LM	22S	APR5FS
WR9HP	ZGR5C	394539	BR2-LM	25C2	BPR4FS
WR9LC	ZGR5A	394812	BR2-LM	25S	BPR4FS
WR9LE	ZGR5A	491055	BKR5E	37C2	BPR4FS-15
WR9LS	ZGR5A	491167	B2-LM	38	BP5ES
WRS5F	BPMR7A	493944	BR2-LM	58	BP-4
WS5E	BM7A	496018	BKR5E	58S	BP-4
WS5F	BPM7A	499608	BKR5E	63	BP-4
WS7E	BM6A	555132	BR2-LM	71	BKR5E
WS7F	BPM6A	557039	CR9E	71-1	BKR5E
WS8E	BM6A	692051	BKR5E	71C2	BKR5E
WS8F	BPM6A	694385	BKR5E	71G	BKR5E
WSR4F	BPMR8Y	696876	BPMR7A	71S	BKR5E

Note: NGK recommends to use the "Torch" part numbering system as a starting point when trying to cross "Chinese" manufacturing brands back to NGK.

Other Part No.	NGK Part No.
CHAMPION (CONT) 	
79	BPR4FS-15
79C2	BPR4FS-15
79S	BPR4FS-15
82	FR5-1
82C2	FR5-1
89	BKR5E-11
101	ZGR5C
102	BR6S
104	BR7ES
113	BR5FS
113C2	BR5FS
120	B6ES
123	BR6ES
129	AR6FS
160	Y-207T
263	R5673-8
266	R5670-7
277	R5672A-9
278	R5672A-8
279	BKR7E
280	R5724-8
284	BKR7E
293	R5671A-11
296	R5671A-9
300	BP6ES
302	BP5ES
302S	BP5ES
304	BPR6EFS
306C	B6HS
3071-2	BKR5EIX-11
308C2	BPR5EY-11
309	CR9E
311	ZFR5E-11
312	BP6HS
318C2	ZFR5F-11
318S	ZFR5F-11
322	BPR5ES-11
322-1	BPR5ES-11
322C2	BPR5ES-11
322S	BPR5ES-11
327	BPR6HS
327C	BPR6HS
328	BP7HS
332	BPR6ES
339	BPR7ES
340	BKR7E

Other Part No.	NGK Part No.
344	BKR6E
344S	BKR6E
345	BKR6E-11
346	BKR6E-11
400	BPR6FS
401	TR4
401C2	TR4
401S	TR4
4025-2	BPR4FS-15
404	BPR5ES
404C2	BPR5ES
404S	BPR5ES
405	BPR5ES
405C2	BPR5ES
405S	BPR5ES
406	BPR5FS
406C2	BPR5FS
406S	BPR5FS
407	TR5-1
407C2	TR5-1
407S	TR5-1
408	TR4
408C2	BPR5EFS
408S	BPR5EFS
409	APR5FS
412	FR5-1
412C2	FR5-1
412S	FR5-1
415	BPR6ES
415-1	BPR6ES
415C2	BPR6ES
415S	BPR6ES
418	BKR6E-11
426	BKR6E-11
430	BKR6E-11
430C2	BKR6E-11
430S	BKR6E-11
431	BKR5E
431-1	BKR5E
431C2	BKR5E
431S	BKR5E
434	ZFR5F-11
435	ZFR5F-11
436S	ZFR5F-11
438	ZFR5N
439	ZFR5F-11
443	LZTR4A-11

Other Part No.	NGK Part No.
444	BKR7E
470	LZTR5A-13
502	AB-6
504	B4ES
506	AB-8
509	AB-6
511	B-4
512	B-4L
516	AB-6
523	AB-6
525	BPR4FS
533	B-4
537	B-6L
538	B-6L
541	AB-7
555	AB-6
564	AB-6
570	LZTR4A-11
587	B-6L
592	BR6S
592-1	BR6S
592C	BR6S
592M	BR6S
592S	BR6S
653	R0373A-10
654	PMR8A
661	R2525-10
662	D9EA
668	R5673-10
669	R5673-10
670	R5673-9
671	R5674-10
672	R5674-9
673	R6061-10
678	BR9HIX
682	R5724-9
683	R5724-9
684	R5724-10
685	R5724-9
686	R5671A-10
687	R5671A-9
688	R5724-8
693	R5671A-10
709	R0045J-10
785	R5671A-8
791	R5672A-10
792	R5672A-9



CROSS REFERENCE CHART SPARK PLUG

Note: NGK recommends to use the "Torch" part numbering system as a starting point when trying to cross "Chinese" manufacturing brands back to NGK.

Other Part No.	NGK Part No.	Other Part No.	NGK Part No.	Other Part No.	NGK Part No.
CHAMPION (CONT)					
794	R5672A-8	827S	BUHW	856	BR4-LM
796	BKR7E	828-1	BZ7HS-10	857	B-4L
801	B8ES	828M	BZ7HS-10	858	BPM7A
801C	B8ES	828S	BZ7HS-10	859	BPMR7A
802	R5673-6	830	BR6HS	860	A6FS
803	B7ES	831	BUHXW-1	861	B2-LM
803C	B7ES	831-1	BZ7HS-10	861-1	B2-LM
805	B9ES	831M	BUHXW-1	861S	B2-LM
805C	B9ES	831S	BZ7HS-10	862	BM7A
806	BP5HS	833-1	BUHW-2	868	BR2-LM
807	B7HS	833M	BUHW-2	868-1	BR2-LM
807-1	B7HS	833S	BUHW-2	868S	BR2-LM
807C	B7HS	835C	B7HS	871	BR6S
807M	B7HS	835	B7HS	872	BPMR6F
808	CR5HSB	837	BUH	872-1	BPMR6F
809C	DCPR8E	837C	BUH	874	BR7HS
809	DCPR8E	838M	BUZHW-2	874-1	BR7HS
810	DCPR7E	840	BMR6A	874C	BR7HS
810C	DCPR8E	840C	BMR6A	874M	BR7HS
810S	DCPR7E	841	B6S	874S	BR7HS
811	B7HS	841-1	B6S	876-1	BUHXW-1
811-1	B7HS	841S	B6S	876M	BUHXW-1
811C	B7HS	843	BM6A	876S	BUHXW-1
811M	B7HS	843-1	BM6A	877	CM-6
813	BP7ES	843S	BM6A	880	BR8ES
813C	BP7ES	844	B-6L	880C	BR8ES
814	BPR7HS	844-1	B-6L	883	BR8HS
814C	BPR7HS	845	B4-LM	883-1	BR8HS
814S	BPR7HS	845-1	B4-LM	883M	BR8HS
816	D8HA	845S	B4-LM	883S	BR8HS
817	ZGR5A	846	BM4A	886M	BUZ8H
818	BR9ES	846-1	BM4A	888	D6HA
818C	BR9ES	846S	BM4A	889	C8HSA
821	B7HS-10	847	BM6F	893	BMR7A
821-1	B7HS-10	847-1	BM6F	895	BR9EG
821M	B7HS-10	849	BM7A	896	B5HS
821S	B7HS-10	849C	BM7A	898	BUZHW
823	B6S	850	BM6F	898-1	BUZHW
823-1	B6S	850C	BM6F	898M	BUZHW
823S	B6S	851	BM7F	900	DCPR9E
824	BUHX	851C	BM7F	904	BPR8ES
825	B7S	852	BPMR8Y	905	DCPR8E
825C	B7S	852-1	BPMR8Y	909	TR4
825S	B7S	852S	BPMR8Y	910	D6HA
827-1	BUHW	854	B-6L	915	BR8EG
827M	BUHW	855	BPM6F	917C	BP5ES
		855C	BPM6F	923	BPR5HS

Note: NGK recommends to use the “Torch” part numbering system as a starting point when trying to cross “Chinese” manufacturing brands back to NGK.

Other Part No.	NGK Part No.
CHAMPION (CONT) 	
924M	BPR7HS-10
929	BPR4HS
929C	BPR4HS
930	BPR4FS-15
931-1	BR6HS
931M	BR6HS
931S	BR6HS
932-1	BPR7HS
932M	BPR7HS
932S	BPR7HS
933-1	BR6HS
933M	BR6HS
933S	BR6HS
934M	BPR6HS
936-1	BP7HS
936M	BP7HS
937	BPR9EIX
938-1	BZ7HS-10
938M	BZ7HS-10
938S	BZ7HS-10
939-1	BPR7HS-10
939M	BPR7HS-10
941-1	BR8HS
941M	BR8HS
942M	BPR4FS-15
942S	BPR4FS-15
946	BKR6E
948	DCPR6E
950M	PZFR5F
952M	PZFR6H
955	PZFR6F-11
955M	PZFR6F-11
956M	IZFR6N-E
956S	IZFR6N-E
959M	PZFR6H
973	BR2-LM
975	LFR6A-11
977	CPR8E
980	BKR5E
985	BKR5E-11
1006	R2525-10
2095	BKR5E
2301	BPR5ES-11
2332	BPR6ES
2338	BKR6E
2412	FR5-1

Other Part No.	NGK Part No.
2415	BPR5ES
2430	BKR5E-11
3032	PTR5A-13
3034	ZFR5LP-13G
3071	BKR5EIX-11
3322	BPR5EIX-11
3322-2	BPR5EIX-11
3344	BKR6EIX-11
3344-2	BKR6EIX-11
3407	TR5-1IX
3407-2	TR5-1IX
3412	FR5-1
3436	FR5-1
3570	LZTR5A-13
4011	APR5FS
4013	BPR5EFS-13
4018	BPR5FS
4018-2	BPR5FS
4019	BPR4FS-15
4025	BPR4FS-15
4113	BR5FS
4113-2	BR5FS
4318	BKR5E
4401	BPR6EFS
4405	BPR5ES
4408	BPR5EFS
4408-2	BPR5EFS
4412	ZFR4F-11
4430	BKR6E-11
4434	BKR5E
4436	BKR5E
4983	BPR5EFS-13
5828	BZ7HS-10
5838	BUZHW
5843	BM7A
5846	BM6A
5847	BM6F
5851	BM7F
5861	B2-LM
5883	BZ7HS-10
5898	BUZHW
5933	BR5HS
5942	BPR4FS
7034	ZFR5LP-13G
7070	PFR6G-11
7071	PFR5G-11
7332	PGR5A-11

Other Part No.	NGK Part No.
7345	PFR6G-11
7346	PFR5G-11
7401	TR55IX
7408	TR4IX
7437	PTR5A-13
7440	PLZTR5A-13
7546	PFR5G-11
7570	LZTR5A-13
7712	PZFR6F-11
7919	IZFR6N-E
7953	IZFR6N-E
7972	PJR7A
7975	LFR5AIX-11
7981	PTR5A-13
8332	BPR7ES
8332-1	BPR7ES
8332-2	BPR7ES
8339	BPR7ES
8339-2	BPR7ES
8405	BPR5ES
8405-1	BPR5ES
8415	BPR6ES
8415-1	BPR6ES
8415-2	BPR6ES
8654	CR8E
8654-2	CR8E
8698	CR7E
8698-2	CR7E
8809	DPR9EA-9
8809-1	DPR9EA-9
8814	BPR6HS
8814-1	BPR6HS
8814-2	BPR6HS
8815	DR7EB
8815-1	DR7EB
8815-2	DR7EB
8819	DR7EB
8819-1	DR7EB
8819-2	DR7EB
8883	BZ7HS-10
8883-2	BZ7HS-10
8902	BR9ES
8902-1	BR9ES
8902-2	BR9ES
8904	BPR8ES
8904-1	BPR8ES
8904-2	BPR8ES



CROSS REFERENCE CHART SPARK PLUG

Note: NGK recommends to use the "Torch" part numbering system as a starting point when trying to cross "Chinese" manufacturing brands back to NGK.

Other Part No.	NGK Part No.	Other Part No.	NGK Part No.	Other Part No.	NGK Part No.
CHAMPION (CONT)					
9001	BKR6EIX	BL7Y	BP7FS	CJ11	BM6A
9002	BKR5EIX	BL8	BR6FS	CJ14	BM4A
9005	IZFR6F11	BL9Y	BP6FS	CJ3	BM7A
9201	IFR5D10	BN12Y	BP5EFS	CJ4	BM7A
9202	BKR5EIX	BN2	B9EFS	CJ6	BM7A
9203	BKR5EIX	BN6Y	BP7EFS	CJ6Y	BPM7A
9204	TR5IX	BN7Y	BP6EFS	CJ7Y	BPM7A
9402	TR5-11X	BN89Y	BP6EFS	CJ8	BM6A
9403	ILTR5A-13G	BN9Y	BP6EFS	CJ86	BM6A
9404	TR55IX	C10YCC	BKR6E	CJ8Y	BPM6A
9405	TR5IX	C12YCC	BKR5E	D10	AB-6
9802	BKR6EIX	C281YC	BKR6E	D14	AB-6
9804	BPR5EIX-11	C53C	R5671A-11	D16	AB-6
9805	IFR6D10	C53CX	R5671A-11	D16J	AB-6
9806	IFR6T11	C55	R5671A-10	D21	AB-6
9179100	PFR6G	C55C	R5671A-10	D23	AB-6
9202064	BKR6EKUB	C55CX	R5671A-10	D6	AB-8
A10	D7EA	C57	R5671A-10	D9	AB-6
A57C	R2525-10	C57C	R5671A-10	D9J	AB-6
A57R	R2525-10	C57CX	R5671A-10	DJ6J	BM7F
A59C	D9EA	C57Y	R5672A-10	DJ7J	BM6F
A5YC	DP9EA-9	C57YC	R5672A-10	DJ7Y	BPM6F
A6	D8EA	C59	R5671A-9	DJ8J	BM6F
A61	D9EA	C59C	R5671A-9	EON 1	BKR6E
A61G	DR9EIX	C59CX	R5671A-9	EON 2	BKR5E
A6G	DR8EIX	C59Y	R5672A-9	EON 3	BPR5EFS
A6Y	DP8EA-9	C59YC	R5672A-9	EON 5	BPR6ES
A6YC	DCR8EIX	C61	R5724-8	EON 6	BPR5ES
A8	D7EA	C61C	R5671A-8	F10	A6FS
A8Y	DP7EA-9	C61CX	R5671A-8	F10C	A6FS
A8YC	DCR7EIX	C61Y	R5672A-8	F11Y	AP5FS
B7	B4ES	C61YC	R5672A-8	F11YC	AP5FS
BL11Y	BP5FS	C63C	R5671A-7	F14Y	AP5FS
BL13Y	BP5FS	C63CX	R5671A-7	F62Y	AP8FS
BL15Y	BP4FS	C63Y	BKR7E	F7Y	AP7FS
BL3	R5673-8	C63YC	BKR7E	F7YC	AP7FS
BL4	B7FS	C65YC	BKR7E	F7YCC	AP7FS
BL5	B7FS	C6BYC	BCPR7ET	F81Y	AP8FS
BL55	R5673-10	C6YCC	BCP7ES	F83Y	AP8FS
BL57	R5673-10	C7Y	BCP7ES	F9Y	AP6FS
BL57Y	R5674-10	C7YC	BCP7ES	F9YC	AP6FS
BL6	BR6FS	C7YCC	BCP7ES	G1	C9E
BL60	R5673-9	C9MCC	ZFR5F	G2	C8E
BL60Y	R5674-9	C9Y	BKR6E	G54V	R0045Q-10
BL62Y	R5674-8	C9YC	BKR6E	G55	C9E
BL64Y	R5674-8	C9YCC	BKR6E	G55C	R0373A-10
		CH68	Y-924J	G55R	R0373A-10

Note: NGK recommends to use the "Torch" part numbering system as a starting point when trying to cross "Chinese" manufacturing brands back to NGK.

Other Part No.	NGK Part No.	Other Part No.	NGK Part No.	Other Part No.	NGK Part No.
CHAMPION (CONT) 		K15J	AB-6	L87Y	BP6HS
G57C	R0373A-10	K3G	AB-8	L87YC	BP6HS
G57R	R0373A-10	K5G	AB-8	L87YCC	BP6HS
G58	C9E	K7	AB-8	L89CM	BP5HS
G59C	PMR8A	K-8	AB-8	L90	B5HS
G61	C8E	K8G	AB-8	L90C	B5HS
G63	C8E	K9	AB-7	L92LCC	BPR5HS
H03	B6S	L10	B6HS	L92Y	BP5HS
H10	B-6L	L12Y	BP5HS	L92YC	BP5HS
H10C	B-6L	L14	B-4H	L92YC4	BP5HS-10
H10J	B-6L	L15Y	BP4HS	L95Y	BP4HS
H11	B-4L	L19V	BUH	L9G	B6HS
H12	B-4L	L20V	BUH	L9J	B6HS
H8	B-6L	L288	B5HS	LB-8	B5HS
H8C	B-6L	L2G	B9HVX	N1	B10ES
H8J	B-6L	L3G	B8HS	N1032Y	BPR10EVX
J10Y	BP6S	L4G	BR7HIX	N10PY	BPR6EIX
J11	B-4	L4J	B7HS	N10Y	BP6ES
J11C	B-4	L5	B7HS	N10Y4	BP6ES-11
J11J	B-4	L55G	B10HS	N10YC	BP5ES
J11Y	BP5S	L61Y	BP8HS	N11Y	BP4ES
J12J	B-2	L64Y	BP7HS	N11YC	BP4EY
J12Y	BP5S	L66Y	BP6HS	N11YC4	BP4EY-11
J12YC	BP5S	L6G	BR7HIX	N11YCC	BP4EY
J13Y	BP5S	L76V	BUHW	N12Y	BP4ES
J14	B-2	L77J	B7HS	N12YC	BP4EY
J14J	B-2	L77J4	B7HS-10	N12YCC	BP4EY-11
J14Y	BP5S	L77JC	B7HS	N13L	ZGR5C
J14YC	BP5S	L77JC4	B7HS-10	N13Y	BP5ES
J17LM	B4-LM	L77V	BUHW	N14LY	ZGR5C
J18Y	BP-4	L78	B7HS	N14Y	BP4EY
J18YC	BP-4	L78C	B7HS	N16Y	BP4ES
J19LM	B2-LM	L78V	BUHW-2	N16YC	BP4EY
J4	B7S	L78YC	BP7HS	N178B	BR8EM
J4C	B7S	L78YC6	BPR7HS-10	N180B	B7EM
J4J	B7S	L7J	B6HS	N2	B9ES
J5	B7S	L81	B7HS	N21	B4ES
J6	B6S	L81Y	BP7HS	N279YC	BP7ES
J63Y	R5670-7	L82	B6HS	N281YC	BP6ES
J6C	B6S	L82C	B6HS	N288	B5ES
J6J	B6S	L82Y	BP6HS	N2C	B9ES
J7	B6S	L82YC	BP6HS	N2G	B9ES
J7J	B6S	L82YCC	BP6HS	N3	B8ES
J8	B6S	L85	B6HS	N3C	B8ES
J8C	B6S	L86	B6HS	N3G	B8ES
J8J	B6S	L86C	B6HS	N4	B7ES
K13	AB-6	L86CC	B6HS	N4C	B7ES



CROSS REFERENCE CHART SPARK PLUG

Note: NGK recommends to use the "Torch" part numbering system as a starting point when trying to cross "Chinese" manufacturing brands back to NGK.

Other Part No.	NGK Part No.	Other Part No.	NGK Part No.	Other Part No.	NGK Part No.
CHAMPION (CONT)					
N4G	B7ES	N8Y	BP6ES	QL77JC4	BZ7HS-10
N4YC	BP9ES	N92Y	BP4ES	QL78C	BR8HS
N5	B6ES	N9BMC	BPR5EKU	QL78V	BUZHW-2
N54R	B10EG	N9BYC	BP5ET	QL78YC	BPR7HS
N57	B10ES	N9Y	BP5ES	QL7J5	BR6HS
N57G	B105EGV	N9YC	BP5EY	QL82C	BR6HS
N57R	B10EG	N9YC4	BP5EY-11	QL82YC	BPR6HS
N59DR	R6061-10	N9YCC	BP5EY	QL86	BR6HS
N59G	B95EGV	N9YCE	BP5ES	QL86C	BR6HS
N5C	B6ES	OBL9Y	BPR6FS	QL87YC	BPR6HS
N5G	B6EVX	OJ11Y	BP6S	QN2	BR9ES
N6	B7ES	OJ12Y	BP5S	QN2C	BR9ES
N60	B9ES	OJ13Y	BP5S	QN2G	BR9EIX
N60R	B8EG	ON11Y	BPR5ES	QN3	BR8ES
N62R	B8EG	ON12Y	BPR5ES	QN3C	BR8ES
N63Y	BP9ES	ON3	BR8ES	QN84	BR9EG
N64Y	BP8ES	P10Y	D6HA	QN86	BR8EG
N65Y	BP7ES	P7	D8HA	R10	D6EA
N66Y	BP6ES	P7Y	D8HA	R6	D8EA
N6Y	BP7ES	P8Y	D6HA	R6G	DR8EIX
N6YC	BP7ES	P-A5HC	D7EA	R6J	D8EA
N6YCC	BP7ES	P-A7HC	D7EA	R8	D7EA
N7	B6ES	PG2PHP	PMR8A	RA10HC	DCPR6E
N74C	BUR6EB-11	PG4PHP	PMR7A	RA2HC	R2525-10
N79Y	BP6ES	P-G7C	C7E	RA4HC	DCR9EIX
N7BYC	BP6ET	P-L7YC4	BP6HS-10	RA4PHP	PMR8A
N7GY	BPR7EIX	P-L9YC	BP6HS	RA507MC	ZKR7A-10
N7Y	BP6ES	P-N5C	B8ES	RA59GC	R2525-10
N7YC	BP6ES	P-RL5SC	BR6HSA	RA6	DR8EA
N7YCC	BP6ES	P-RZ9HC	CR6HSA	RA6HC	DCR8EIX
N7YCX	BP6ES	P-Z7HC	C7HSA	RA6Y	DPR8EA-9
N8	B6ES	P-Z9HC	C6HSA	RA6YC	DPR8EA-9
N80	B10EG	QC10PEP	PZFR6H	RA7YC	DCPR7E
N80G	B11EGV	QC10PEPB	IZFR6N-E	RA8GHC	DCPR6E
N82	B10EG	QC12GMC	PZFR5F	RA8HC	DCR7EIX
N82G	B105EGV	QC12PEPA	PZFR6H	RA8PHP	PJR7A
N84	B9EG	QC12PEPB	IZFR6N-E	RA8Y	DPR7EA-9
N84G	B95EGV	QC12YC	BKR6E	RA8YC	DPR7EA-9
N86	B9EG	QC9MC4	ZFR6F-11	RAX92C	DR9EA
N86G	B9EGV	QJ19LM	BR2-LM	RAX92DC	JR9C
N87	B8EG	QL16V	BUZ8H	RAX92YC	DPR9EA-9
N87G	B8EGV	QL55	BR10HIX	RAX94C	DR8EA
N89GY	BP6ES	QL57	BR9HIX	RAX94YC	DPR8EA-9
N89Y	BP5ES	QL6VC	BUZ8H	RAX96C	DR7EA
N8GY	BPR6EIX	QL76V	BUZHW	RAX96YC	DPR7EA-9
N8L	ZGR5C	QL77CC	BZ7HS-10	RBL11Y	BPR5FS
		QL77J4	BZ7HS-10	RBL11Y6	BPR5FS-15

Note: NGK recommends to use the "Torch" part numbering system as a starting point when trying to cross "Chinese" manufacturing brands back to NGK.

Other Part No.	NGK Part No.
CHAMPION (CONT) 	
RBL12	BR5FS
RBL13Y	BPR5FS
RBL13Y6	BPR5FS-15
RBL15Y	BPR4FS
RBL15Y4	BPR4FS-11
RBL15Y6	BPR4FS-15
RBL16Y	BPR4FS
RBL17Y	BPR4FS
RBL17Y6	BPR4FS-15
RBL8	BR6FS
RBL8-6	BR6FS-15
RBL9Y	BPR6FS
RBN12Y	BPR5EFS
RBN13Y	BPR5EFS
RBN14Y	BPR5EFS
RBN9Y	BPR6EFS
RC10DMC	BKR5EK
RC10ECC	ZFR6F-11
RC10PMPA	PZFR5F
RC10PYP4	PFR5G-11
RC10PYPB4	PFR5G-11
RC10VTYC4	BKUR5ET-10
RC10YC	BKR5E
RC10YC4	BKR5E-11
RC10YCC	BKR5EZ
RC10YCL	BKR5EZ
RC11PYPB4	PFR5G-11
RC11ZYC4	ZFR5E-11
RC12ECC	ZFR5N
RC12LC4	ZFR5F-11
RC12LYC	ZFR5N
RC12LYC5	ZFR5F-11
RC12MC4	ZFR5F-11
RC12MC5	ZFR5F-11
RC12MCC4	ZFR5F-11
RC12PEC5	ZFR5LP-13G
RC12PYP	PFR5G-11
RC12YC	BKR5E
RC12YC5	BKR5E-11
RC12YV5	BKR5E-11
RC14E5	FR5-1
RC14YC	BKR5E
RC600MC	ZFR5F-11
RC6YC	BKR7E
RC7BMC	BCPR6ET
RC7GYG	BKR6EIX

Other Part No.	NGK Part No.
RC7PYCB	BKR7EIX
RC7PYCB4	FR6AP-10
RC7PYCBX	BKR7EIX
RC7Y	BKR7E
RC7YC	BKR7E
RC7YC3	BKR7E
RC7YC4	BKR7E-11
RC7YCC	BKR7E
RC7YCC4	BKR7E-11
RC87LYC	BKR6E
RC87YC	BKR6E
RC87YCL	BKR6E
RC89PYC	BKR5EIX
RC8BYC	BKR5EKC
RC8PYP	PFR6G
RC8PYP4	PFR6G-11
RC8PYPB4	PFR6G-11
RC8YC	BKR5E
RC8YC4	BKR6E-11
RC8YCC	BKR6E
RC9BMC	BKR5EKU
RC9GYC4	PFR6B-11
RC9MC4	ZFR5F-11
RC9MCC	ZFR5F
RC9TMC	BKR6EKUB
RC9Y	BKR6E
RC9YC	BKR6E
RC9YC4	BKR6E-11
RC9YC5	BKR6E-11
RC9YCC	BKR6E
RC9YCN4	BKR6E-11
RCJ4	BMR7A
RCJ501H	BPMR4A
RCJ6	BMR7A
RCJ6Y	BPMR7A
RCJ7Y	BPMR7A
RCJ8	BMR6A
RCJ8Y	BPMR6A
RD14	AB-6
RD16	AB-6
RD16J	AB-6
RD9	AB-6
RDJ7J	BMR6F
RDJ7Y	BPMR6F
RDJ8J	BMR6F
RE10LC	TR5-11X
RE10PMC5	PTR5A-13

Other Part No.	NGK Part No.
RE14MCC4	LZTR4A-11
RE14MCC5	LZTR4A-11
RE16MC	LZTR4A-11
RE7YCC	PTR5A-13
REA12WMB4	LZKAR6AP-11
REA513WYPB	ILKR7B8
REA8MCL	LZKAR7A
REA9MCL	LFRR5B
REC10WYP4	ILFR5B11
REC10YC4	LFRR6A-11
RF10	AR6FS
RF10C	AR6FS
RF11Y	APR6FS
RF11YC	APR6FS
RF14Y	APR5FS
RF14YC	APR5FS
RF18YC	APR5FS
RF9Y	APR6FS
RF9Y5	APR6FS
RF9YC	APR6FS
RFN14LY	ZFR5F-11
RG4HC	CR9EB
RG4PHP	PMR8A
RG4YCX	CR9EIX
RG6YC	CPR8E
RG6YCA	CPR8E
RG92C	CR9E
RG92DC	CR9EK
RG94C	CR8E
RGU92C	CR9EH-9
RGU94C	CR8EH-9
RH10C	B-6L
RH12	B-6L
RH18Y	B-4L
RH8C	B-6L
RJ10Y	BP6S
RJ11	BR6S
RJ11Y	BP5S
RJ12	BR6S
RJ12C	BR6S
RJ12Y	BP5S
RJ12YC	BP5S
RJ14Y	BP5S
RJ14YC	BP5S
RJ17LM	BR4-LM
RJ18Y	BP-4
RJ18YC	BP-4



CROSS REFERENCE CHART SPARK PLUG

Note: NGK recommends to use the "Torch" part numbering system as a starting point when trying to cross "Chinese" manufacturing brands back to NGK.

Other Part No.	NGK Part No.	Other Part No.	NGK Part No.	Other Part No.	NGK Part No.
CHAMPION (CONT)					
RJ19HX	BR2-LM	RN13LYC	ZGR5C	RS14PYP6	TR55IX
RJ19LM	BR2-LM	RN13LYC5	ZGR5A	RS14YC	BPR5EFS
RJ20Y	BP-4	RN14LY	ZGR5C	RS14YC6	TR55IX
RJ6	BR6S	RN14MC5	ZGR5A	RS15LYC	TR4
RJ6C	BR6S	RN14Y	BPR4ES	RS16YC	TR4
RJ6J	BR6S	RN14Y6	BPR5ES-11	RS17YX	TR4
RJ6J	BR6S	RN14YC	BPR4EY	RS5C	BR7EFS
RJ7	BR6S	RN16Y	BPR4ES	RS9YC	BPR6EFS
RJ8	BR6S	RN180B	B7EM	RS9YCC	BPR6EFS
RJ8C	BR6S	RN2	BR9ES	RV12C	BR5FS
RJ8J	BR6S	RN2C	BR9ES	RV12YC	BPR5FS
RL12Y	BPR6HS	RN2G	BR9EIX	RV12YC6	BPR5FS-15
RL19	BR5HS	RN3	BR8ES	RV15YC	BPR4FS
RL4J	BR7HS	RN3C	BR8ES	RV15YC4	BPR4FS-11
RL77J	BR7HS	RN3G	BR9EIX	RV15YC6	BPR4FS-15
RL78	BR7HS	RN4	BR7ES	RV17YC	BPR4FS
RL78C	BR7HS	RN4C	BR7ES	RV17YC6	BPR4FS-15
RL7J	BR6HS	RN4YC	BPR8ES	RV19YC	BPR4FS
RL82	BR6HS	RN5	BR6ES	RV19YC6	BPR4FS-15
RL82C	BR6HS	RN57YC	BPR9EIX	RV8C	BR6FS
RL82Y	BPR6HS	RN5C	BR6ES	RV8C6	BR6FS-15
RL82YC	BPR6HS	RN6	BR7ES	RV91MC	BPR4FS-15
RL82YCC	BPR6HS	RN6Y	BPR7ES	RV92YC	BPR4FS-15
RL85	BR6HS	RN6YC	BPR7ES	RV9YC	BPR6FS
RL86	BR6HS	RN74C	BUR6EB-11	RZ7C	CMR7H
RL86C	BR6HS	RN7Y	BPR6ES	RZ94C	CR8HSA
RL87Y	BPR6HS	RN7YC	BPR6ES	RZ96C	CR7HSA
RL87YC	BPR6HS	RN7YCC	BPR6ES	RZN12Y	BPR5EFS
RL90	BR5HS	RN8	BR5ES	RZN12Y5	BPR5EFS
RL95YC	BPR4HS	RN8L	ZGR5C	S10YCC	BP5EFS
RN10GY	BPR6EIX	RN9BMC	BPR5EY	S12YC	BP5EFS
RN10PYP4	PGR5A-11	RN9GY	BPR5EIX	S279YC	BP6EFS
RN10VTYC4	BUR5ET	RN9Y	BPR5ES	S281YC	BP6EFS
RN10Y	BPR6ES	RN9YC	BPR5ES	S379YC	BP7EFS
RN10Y4	BPR6ES-11	RN9YC4	BPR5ES-11	S57C	R5724-9
RN11Y	BPR4ES	RN9YCC	BPR5ES	S57YC	R5724-10
RN11YC	BPR4ES	RP7	DR8HS	S59C	R5724-9
RN11YC4	BPR5ES-11	RS10LC	TR5-1IX	S59YC	R5724-9
RN11YCC	BPR4ES	RS12PLP	TR5-1IX	S61YC	R5724-8
RN12GY	BPR4EVX	RS12PYP	TR5IX	S7YC	BP7EFS
RN12MC4	BPR5EY-11	RS12YC	BPR5EFS	S9YC	BP6EFS
RN12Y	BPR4ES	RS12YC6	BPR5EFS-13	UD16	AB-6
RN12YC	BPR4ES	RS13LYC	TR4	UF-11Y	AP6FS
RN12YC4	BPR5ES-11	RS13LYC5	BPR5EFS	UF-14Y	AP4FS
RN12YC6	BPR5ES-11	RS14LC	TR5-1	UF-9Y	AP6FS
RN12YCC	BPR4ES	RS14LYC	TR4	UJ11G	B-4
RN13L	ZGR5C	RS14PYP	TR4IX	UJ12	B-2

Note: NGK recommends to use the "Torch" part numbering system as a starting point when trying to cross "Chinese" manufacturing brands back to NGK.

Other Part No.	NGK Part No.
CHAMPION (CONT) NGK	
UJ2J	B8S
UJ4J	B7S
UJ6	B6S
UJ8	B6S
UJ81C	B7S
UJ81J	B7S
UK10	AB-6
UL17V	BUHXW-1
UL18V	BUHX
UL4J	B7HS
UL77V	BUHXW-1
UL81C	B7HS
UL81J	B7HS
UL82Y	BP7HS
UN79Y	BP6ES
V12YC	BP5FS
V4C	B7FS
V55C	R5673-10
V57C	R5673-10
V57YC	R5674-10
V59C	R5673-9
V59YC	R5674-9
V61	R5673-8
V63C	R5673-7
V9YC	BP6FS
XC12PEPB	PZFR6H
XC92YC	BKR5E
XJ10Y	BP6S
Y82	CM-6
Z10	C6HSA
Z12	C6HSA
Z6	C8HSA
Z8	C7HSA
Z9Y	C7HSA
Z9YC	CR6HSB
CYC NGK	
B7ZH	BP5HS
C7ZH	C6HSA
DELPHI NGK	
41-970	PTR5C-13
DENSO NGK	
FK16PR11	DF5A-11A
FK20HBR11	DFH6B-11A
FK20HBR11-T	DFH6B-11A
FK20HR11	DILFR6D11
FXE20HE11	DF6H-11A

Other Part No.	NGK Part No.
FXE20HR11	DF6H-11B
FXE22HR11	DF7H-11B
FXE24HR11	DF8H-11B
IA01-32	R7282A-105
IAE01-32	R7282-105
IFT16	UR5IX
IHU27	IMR9C-9H
IK01-24	R7434-8
IK02-24	R7434-8
IK16	BKR5EIX-11
IK16F	BKR5EIX-11
IK16FJ	ZFR5FIX-11
IK16X	BKR5EIX
IK20	BKR6EIX-11
IK20F	BKR6EIX-11
IK20FJ	ZFR6FIX-11
IK20X	BKR6EIX
IK22	IRIWAY7
IK22G	IFR7G-11KS
IK24	IRIWAY8
IK27	IRIWAY9
IK27C	FR9BI-11
IK27C11	FR9BI-11
IKH01-27	R7438-9
IKH16	LF5AIX-11
IKH20	LF6AIX-11
IKH22	LF7AIX
IKH27	R7437-9
IQ16	BCPR5EIX-11
IQ20	BCPR6EIX-11
IQ20F	BCPR6EIX-11
IQ22	IRITOP7
IQ24	IRITOP8
IQ27	IRITOP9
IRE01-31	R7420-10
IRE01-32	R7420-105
IRE01-34	R7420-11
IRE01-35	R6725-115
IT16	TR5IX
IT20	TR6IX
IT22	TR7IX
IT24	TR8IX
ITF16	UR5IX
ITF20	UR6IX
ITL20	LZTR6AIX-13
ITV22	LTR7IX-11
IU01-27	R0373A-9

Other Part No.	NGK Part No.
IU01-31	R0373A-10
IU22	CR7EIX
IU24	CR8EIX
IU27	CR9EIX
IU27D	CR9EIA-9
IU31	CR10EIX
IUF22	CR7HIX
IUF24	CR8HIX
IUH24	CR8EHIX-9
IUH24D	IMR8C-9H
IUH27	CR9EHIX-9
IUH27D	IMR9C-9H
IW01-24	R7376-8
IW01-31	R7376-10
IW06-31	R7376-10
IW16	BPR5EIX-11
IW20	BPR6EIX-11
IW22	BPR7EIX
IW24	BR8EIX
IW27	BR9EIX
IW31	BR10EIX
IWF20	BPR6HIX
IWF22	BR7HIX
IWF24	BR8HIX
IWF27	BR9HIX
IWM01-32	R6179A-105P
IWM24	BR8ECMIX
IWM27	BR9ECMIX
IWM31	BR10ECMIX
IX22	DR7EIX
IX22B	DPR7EIX-9
IX24	DR8EIX
IX24B	DPR8EIX-9
IX27	DR9EIX
IX27B	DPR9EIX-9
IXG24	DPR8ZIX
IXU01-31	R2525-10
IXU01-34	R2349-11
IXU22	DCPR7EIX
IXU22C	DCPR7EIX
IXU24	IRIMAC8
IXU27	IRIMAC9
J14CR-U	ZGR5A
J16AR-U11	BRE527Y-11
J16AY	BPR5EY-11
J16AYR	BPR5EJ
J16BR-U	BRE529Y



CROSS REFERENCE CHART SPARK PLUG

Note: NGK recommends to use the "Torch" part numbering system as a starting point when trying to cross "Chinese" manufacturing brands back to NGK.

Other Part No.	NGK Part No.	Other Part No.	NGK Part No.	Other Part No.	NGK Part No.
DENSO (CONT)					
J16BR-U11	BRE529Y-11	K22P11	BK7EK-N-11	MA20PR-U	APR6FS
J16B-U11	BE529Y-11	K22PB	BKUR7ET	MA20P-U	AP6FS
J16CR-U	BPR5EY	K22PBR-S	BKUR7ET	MA20R-U	AR6FS
J16C-U	BPR5EY	K22PR-L11	BKR7E-11	MA20R-U11	AR6FS
J16HR-U10	ZGR5C	K22PR-TP11	BKR7EIX-11	MW17	AB-6
J20AY	BPR6EY-11	K22PR-U	BKR7E	MW22	AB-7
K14PR-U11	BKR4E-11	K22PR-U11	BKR7E-11	MW9	AB-2
K16GPR-U11	ZFR5E-11	K22PR-ZU	BKR7EVX	P16PR11	PGR5A-11
K16HPR-U11	LF5A-11	K22PR-ZU11	BKR7EIX-11	P16PR8	PGR5A-11
K16PR-TP11	BKR5EIX-11	K22P-U11	BKR7E-11	P16R	BPR5EP-11
K16PR-U	BKR5E	K22TM11	BK7EK-N-11	P16R13	BPR5EP-11
K16PR-U11	BKR5E-11	K22TMR	BKR7EKC-N	P20PR11	PGR6A-11
K16PR-ZU11	BKR5EIX-11	K22TMR11	BKR7EKC-N-11	P20PR8	PGR6A
K16PSR-B8	FR5EI	K22TNR	BKR7EKC	P20PR-P8	PGR6A
K16P-U	BKR5E	K22TNR-S	BKR7EKC	P20PR-S11	BPR6EIX
K16P-U11	BKR5E-11	K24PR-U11	BKR8E-11	P20R8	BPR6EP-8
K16R-U	BKR5EYA	K24PRZU	IRIWAY8	P22PR8	PGR7A
K16R-U11	BKR5EYA-11	K27AZ	IRIWAY9	PK16PR11	PFR5B-11
K16R-ZU11	BKR5EIX-11	K27PR-ZU	IRIWAY9	PK16PR8	PFR5G-11
K16TNR-S9	BKR5EKC	K29AZ	IRIWAY9	PK16PR-L11	PFR5G-11
K16TR11	BKR5EKB-11	KJ14CR11	ZFR4F-11	PK16PR-P11	PFR5J-11
K16-U	BKR5EYA	KJ14CR-L11	ZFR4F-11	PK16R11	BKR5EP-11
K16-U11	BKR5EYA-11	KJ16CR	ZFR5F	PK16R-11	BKR5EP-11
K20HR-U11	LF6C-11	KJ16CR11	ZFR5J-11	PK16R8	BKR6EP-8
K20PBR	BKUR6ET	KJ16CR-11	ZFR5F-11	PK16TR11	BKR5EKP-11
K20PBR-S10	BKUR6ET-10	KJ16CR-L11	ZFR5F-11	PK16TR-11	BKR5EKP-11
K20PR-L11	BKR6E-N-11	KJ16CR-U11	ZFR5F-11	PK16TR13	BKR5EKP-13
K20PR-TP11	BKR6EVX-11	KJ20CR11	ZFR6J-11	PK20GR8	BKR6EPA-8
K20PR-U	BKR6E	KJ20CR-11	ZFR6F-11	PK20PR11	PFR6B-11
K20PR-U11	BKR6E-11	KJ20CR-L11	ZFR6F-11	PK20PR-11	PFR6B-11
K20PR-ZU11	BKR6EVX-11	KJ20CR-U11	ZFR6F-11	PK20PR8	PFR6G-11
K20PSR-B8	FR6EI	KJ20DR-M11	ZFR6K-11	PK20PR-L11	PFR6G-11
K20P-U	BKR6E	KJ20SR11	ZFR6FIX-11	PK20PR-L13	PFR6G-13
K20P-U11	BKR6E-11	KJ22CR11	ZFR7F-11	PK20PR-P	PFR6J
K20R-U	BKR6EYA	KJ22CR-L11	ZFR7F-11	PK20PR-P11	PFR6J-11
K20R-U11	BKR6EYA-11	KJ22CR-L8	ZFR7F	PK20PR-P8	PFR6J
K20R-Z	BKR6EIX	LP20R-U	BPR6EY	PK20PR-TP	PFR6M
K20R-ZU11	BKR6EVX-11	LP20-U	BP6EY	PK20PTR-S9	BKR6EKPA
K20TMR11	BKR6EKC-N-11	M17	AB-6	PK20R11	BKR6EP-11
K20TNR	BKR6EKC	M22	AB-7	PK20R-11	BKR6EP-11
K20TNR-S	BKUR6EK	M24S	AB-8	PK20R-13	PFR6G-13
K20TNR-S9	BKR6EK	MA14P-U	AP4FS	PK20R8	BKR6EP-8
K20TR11	BKR6EKB-11	MA16PR-U	APR5FS	PK20TR11	BKR6EKP-11
K20TXR	BKR6EKUB	MA16PR-U11	APR5FS	PK20TR-11	BKR6EKP-11
K20-U	BKR6EYA	MA16PR-U15	APR5FS	PK22PR11	PFR7B-11
K20-U11	BKR6EYA-11	MA16P-U	AP5FS	PK22PR8	PFR7B
		MA17P-U	AP6FS	PK22PR-L11S	PFR7G-11S

Note: NGK recommends to use the "Torch" part numbering system as a starting point when trying to cross "Chinese" manufacturing brands back to NGK.

Other Part No.	NGK Part No.
DENSO (CONT) 	
PK22PR-TP	PFR7M
PKJ16CR8	PZFR5F
PKJ16CR-L11	PZFR5F-11
PKJ16CR-L13	PZFR5F-11
PKJ20CR-11	PZFR6F-11
PKJ20CR8	PZFR6F-11
PKJ20CR-L11	PZFR6F-11
PKJ20CR-M11	PZFR6F-11
PQ16R	BCPR5EP-11
PQ16R13	BCPR5EIX-11
PQ16R-13	BCPR5EIX-11
PQ16R8	BCPR6EP-11
PQ20R	BCPR6EP-11
PQ20R13	BCPR6EIX-11
PQ20R8	PFR6G
PQ20R-P11	BCPR6EIX-11
PQ20R-P8	BCPR6EP-N-8
PT16EPR-C13	PTR5C-13
PT16EPR-L13	PTR5C-13
PT16VR10	PTR5A-10
PT16VR13	PTR5A-13
PTJ16R15	PZTR5A-15
Q14R-U11	BCPR4EY-11
Q16PR-TP11	BCPR5EIX-11
Q16PR-U	BCPR5E
Q16PR-U11	BCPR5E-11
Q16PR-ZU11	BCPR5EIX-11
Q16P-U11	BCPR5E-11
Q16R-U	BCPR5EY
Q16R-U11	BCPR5EY-11
Q16R-ZU11	BCPR5EIX-11
Q16-U	BCP5E
Q16-U11	BCPR5E-11
Q16-ZU11	BCPR5EIX-11
Q20PR-P11	BCPR6EVX-11
Q20PR-TP11	BCPR6EVX-11
Q20PR-U	BCPR6E
Q20PR-U11	BCPR6EY-11
Q20PR-ZU11	BCPR6EVX-11
Q20P-U	BCP6ES
Q20P-U11	BCPR6E-11
Q20R-U	BCPR6EY
Q20R-U11	BCPR6EY-11
Q20R-ZU11	BCPR6EVX-11
Q20-U	BCPR6E
Q20-U11	BCPR6E-11

Other Part No.	NGK Part No.
Q20-ZU11	BCPR6EVX-11
Q22PR-P11	BCPR7EVX-11
Q22PR-U	BCPR7ES
Q22PR-U11	BCPR7E-11
Q22PR-ZU	BCP7EVX
Q22PR-ZU11	BCPR7EVX-11
Q22P-U	BCPR7EIX
Q22P-U11	BCP7E-11
Q24PRZ-U	IRIWAY8
Q27PR-ZU	IRIWAY9
QJ16AR-U	ZFR5F
QJ16C11	ZFR5A-11
QJ16CR11	ZFR5A-11
QJ16HR-U	FR5-1
QJ20C11	ZFR6A-11
QJ20CR11	ZFR6A-11
QJ20CR-11	ZFR6A-11
QJ22C-11	ZFR7F-11
QJ22CR11	ZFR7F-11
QL22TR-S	BCPR7EKD
RU01-31	R0045Q-10
S22PR-A7	IGR7A
S-29	SD10A
S29A	BUR7EQ
S-29A	SD10A
S31A	BUR9EQ
S-31A	SD11A
SC20HR11	ILKAR7B11
SF10	BUHXW-1
SF-10	BUHX
SF-24	BU8H
SF50	BUHW
SF-50	BUHW
SF51	BUHW-2
SF-51	BUHW-2
SK16HR11	ILFR5T11
SK16PR-A11	IFR5E11
SK16PR-E11	BKR5EIX-11
SK16PR-L11	IFR5G-11K
SK16R11	IFR5T11
SK16R-P11	IFR5T11
SK20BGR11	HB6AIX-11P
SK20HPR-L11	ILFR6J-11K
SK20HR11	ILFR6T11
SK20PR-A11	IFR6E11
SK20PR-A8	IFR6E11
SK20R11	IFR6T11

Other Part No.	NGK Part No.
SK20R-P11	IFR6T11
SK22PR-M11	IFR7G-11KS
SK22PR-M11S	IFR7G-11KS
SKJ16CR-A8	PZFR5F
SKJ16CR-L11	PZFR5F-11
SKJ16DR-M11	IZFR5K11
SKJ20CR-A8	IZFR6F11
SKJ20DR-M11	IZFR6K11
SKJ20DR-M11S	IZFR6K-11S
SKJ20DR-M13	IZFR6K13
SVK20RZ11	IFR6J11
SVK20RZ8	BKR6EIX-P
SXU22HCR11	ILZKR7B11
SXU22HCR11S	ILZKR7B-11S
SXU22HDR8	ILKR7B8
T14PR-U	BPR4FS
T14PR-U15	BPR4FS-15
T16EPR-U	BPR5EFS
T16EPR-U15	BPR5EFS-13
T16EX-U	BP5EFS
T16NR-U11	BPR5EFS
T16PR-U	BPR5FS
T16PR-U11	BPR5FS-11
T16PR-U15	BPR5FS-15
T16PR-U20	BPR4FS-15
T16P-U	BP5FS
T16R-U	BR5FS
T20EPR-U	BPR6EFS
T20EPR-U15	BPR6EFS-15
T20EP-U	BP6EFS
T20EP-U15	BPR6EFS-15
T20EX-U	BP6EFS
T20MP-U	BPM6F
T20M-U	BM6F
T20NR-U11	TR6
T20PR-U	BPR6FS
T20PR-U11	BPR6FS
T20PR-U15	BPR6FS
T20P-U	BP6FS
T20R-U	BR6FS
T20R-U15	BR6FS-15
T22EP-U	BP7EFS
T22M-U	BM7F
TR20	BR6HS
TR22	BR7HS
TR22-10	BR7HS-10
TR24	BR8HS



CROSS REFERENCE CHART SPARK PLUG

Note: NGK recommends to use the "Torch" part numbering system as a starting point when trying to cross "Chinese" manufacturing brands back to NGK.

Other Part No.	NGK Part No.	Other Part No.	NGK Part No.	Other Part No.	NGK Part No.
DENSO (CONT)					
TR24-10	BR8HS-10	U24FS-L	C8HSA	VQ16	BCPR5EIX-11
U14FSR-UB	CR4HSB	U24FSR-C	LR8A	VQ20	BCPR6EIX-11
U14FS-UB	CR4HSB	U24FSR-U	CR8HSA	VUH24D	IMR8C-9H
U16FER9	CR5EH-9	U24FSR-ZU	CR8HIX	VUH24Z	IMR8C-9H
U16FER-9	CR5EH-9	U24FS-U	C8HSA	VUH27D	IMR9C-9H
U16FS-L	CR5HSA	U24FS-ZU	CR8HIX	VUH27ES	IMR9C-9HES
U16FSR-L	CR5HSA	U27ES-N	C9E	VUH27Z	IMR9A-9H
U16FSR-U	CR5HSA	U27ES-NZU	CR9EIX	VW20T	BPR6EIX
U16FSRUB	CR5HSB	U27ES-N-ZU	CR9EIX	VW22PR-DA7	IGR7A-G
U16FSR-UB	CR5HSB	U27ESR-N	CR9E	VX22BC	IJR7A9
U16FS-U	CR5HSA	U27ESR-NB	CR9EB	VX22BZ	IJR7A9
U16FS-UB	CR5HSB	U27ESR-NZU	CR9EIX	VXU22	DCPR7EIX
U17F	CR5HSA	U27ETR	CR9EK	W14	B-4
U20EPR9	CPR6EA-9	U27FE9	CR9EH-9	W14E	B4ES
U20ESR-N	CR6E	U27FER9	CR9EH-9	W14EP	BP4ES
U20FS	C6HSA	U27FER-ZU9	CR9EHIX-9	W14EPR	BPR4ES
U20FS-L	C6HSA	U27FE-ZU9	CR9EHIX-9	W14EPR-U	BPR4ES
U20FSR-L	CR6HSA	U31ESN-ZU	CR10EIX	W14EP-U	BP4ES
U20FSR-U	CR6HSA	U31ESR-N	CR10E	W14EXR-U	BPR4EY
U20FS-U	C6HSA	U31ESRNZU	CR10EIX	W14EXR-U11	BPR4EY
U20FSZU	CR7HIX	U31ETR	CR10EK	W14EXR-U13	BPR4ES
U20M-U	CM-6	U31FE-ZU-9	CR9EHIX-9	W14EXR-ZU	BPR4EVX
U21FB	C6HSA	VCH20	ILKAR7B11	W14EX-U	BP4EY
U22EPR9	CPR7EA-9	VFKBH20	DFH6B-11A	W14EX-U11	BP4EY-11
U22EPR-U	CPR7EA-9	VFKH20	DILFR6D11	W14EX-U13	BPR4ES
U22ES-N	C7E	VFXEH20	DF6H-11B	W14EX-ZU	BPR4EVX
U22ESR-N	CR7E	VFXEH20E	DF6H-11A	W14F	B-4H
U22ETR	CR7EK	VFXEH22	DF7H-11B	W14FP	BP-4H
U22FER9	CR7EH-9	VK16	BKR5EIX-11	W14FP-L	BP4HS
U22FS	C7HSA	VK16PRZ-11	IZFR5K11	W14FPR	BP4HS
U22FS-L	C7HSA	VK16PR-Z11	IFR5L11	W14FPR-L	BPR4HS
U22FSR-L	CR7HSA	VK20	BKR6EIX-11	W14FPR-U	BPR4HS
U22FSR-U	CR7HSA	VK20PRZ-11	IZFR6K11	W14FPR-UL	BPR4HS
U22FS-U	C7HSA	VK20PR-Z11	IFR6L11	W14FPR-UL10	BPR4HS-10
U22FS-ZU	CR7HIX	VK20T	BKR6EIX	W14FP-U	BP-4H
U24ES-N	C8E	VK20Y	BKR6EIX-P	W14FP-UL	BP4HS
U24ESR-N	CR8E	VK22	BKR7EIX	W14FPUL10	BPR4HS-10
U24ESR-NB	CR8EB	VK22PRZ11	IFR7L11	W14FP-UL10	BP4HS-10
U24ESR-NZU	CR8EVX	VK22PR-Z11	IFR7L11	W14FR-U	BR4HS
U24ETR	CR8EK	VK24PR-Z11	IFR8H11	W14F-U	B-4H
U24FB	C8HSA	VK27PR-Z11	IFR9H11	W14F-U10	B-4H
U24FE9	CR8EH-9	VKA20	HB6AIX-11P	W14L	B-4L
U24FER9	CR8EH-9	VKH16	LFR5AIX-11	W14LMR-US	BR4-LM
U24FER-ZU9	CR8EHVX-9	VKH20	LFR6AIX-11	W14LM-U	B4-LM
U24FS	C8HSA	VKH22	LFR7AIX	W14LM-US	B4-LM
U24FS-C	LR8A	VKJ20RZ-M11	IZFR6F11	W14MPRU10	BPMR4A-10
		VNH27Z	IMR9B-9H	W14MPR-U10	BPMR4A-10

Note: NGK recommends to use the “Torch” part numbering system as a starting point when trying to cross “Chinese” manufacturing brands back to NGK.

Other Part No.	NGK Part No.
DENSO (CONT) 	
W14MPU10	BPMR4A-10
W14MR-U	BMR4A
W14M-U	BM4A
W14MU10	BM4A
W14M-US	BM4A
W14P	BP5S
W14PR-U	BP-4
W14P-U	BP-4
W14-U	B-4
W14-U10	B-4
W14US	B-4
W14-US	B-4
W16EKR-S11	BUR5EB-11
W16EK-S11	BUR5EB-11
W16EP	BP5ES
W16EP11	BP5ES-11
W16EP-B	BP5EY
W16EP-GU	BPR5EIX
W16EPR	BPR5ES
W16EPR11	BPR5ES-11
W16EPR-S11	BPR5ES-11
W16EPR-U	BPR5E
W16EPR-U10	BPR5E-11
W16EPR-U11	BPR5E-11
W16EP-U	BP5EY
W16EP-U10	BP5EY-11
W16EP-U11	BP5EY-11
W16EP-ZU	BPR5EIX
W16ES	B5ES
W16ES-L	B5ES
W16ESL-11	BR5ES
W16ES-L11	BUR5EB-11
W16ESR-L	BR5ES
W16ESR-L11	BUR5EB-11
W16ESR-U	BR5ES
W16ES-U	B5ES
W16ET-L	BPR5EY
W16ETR-S	BPR5EIX-11
W16EX	BP5EY
W16EXR-U	BPR5EY
W16EXR-U11	BPR5EY-11
W16EXR-U13	BPR5ES-13
W16EXR-ZU	BPR5EIX
W16EX-U	BP5EY
W16EX-U11	BP5EY-11
W16EX-U13	BP5ES-11

Other Part No.	NGK Part No.
W16EX-ZU	BPR5EIX
W16FP	BP5HS
W16FPR	BPR5HS
W16FPR-U	BPR5HS
W16FP-U	BP5HS
W16FP-U10	BP5HS-10
W16FP-UL	BP5HS
W16FS	B5HS
W16FSR	BR5HS
W16FS-U	B5HS
W16LS	B-6L
W16PR-U	BP5S
W16P-U	BP5S
W17	B6S
W17ES	BR6ES
W17FP	BP6HS
W17P	BP6S
W17PR-U	BP6S
W17P-U	BP6S
W20DTR-S	BPR6EKB
W20EKR-S11	BUR6EB-11
W20EK-S11	BUR6EB-11
W20EP	BP6ES
W20EP11	BP6ES-11
W20EPB	BP6ET
W20EPBR-S	BUR6ET
W20EP-GU	BPR6EIX
W20EPR	BPR6ES
W20EPR11	BPR6ES-11
W20EPR-S11	BUR6EA-11
W20EPR-U	BPR6ES
W20EPR-U10	BPR6ES-11
W20EPR-U11	BPR6ES-11
W20EPR-ZU	BPR6EIX
W20EPR-ZU11	BPR6EIX-11
W20EP-S11	BUR6EA-11
W20EP-U	BP6ES
W20EP-U10	BP6ES-11
W20EP-U11	BP6ES-11
W20EP-ZU	BPR6EIX
W20ES	B6ES
W20ES-GU	B6EVX
W20ES-L	B6ES
W20ES-L11	BUR6EB-11
W20ESR	BR6ES
W20ESR-L	BR6ES
W20ESR-L11	BUR6EB-11

Other Part No.	NGK Part No.
W20ESR-U	BR6ES
W20ES-U	B6ES
W20ES-U11	B6ES
W20ES-ZU	B6EVX
W20ET-L	BPR6EKN
W20ETR-L	BPR6EKN
W20ETR-L8	BPR6EKN
W20EXR-U	BPR6EY
W20EXR-U11	BPR6EY-11
W20EXR-U13	BPR6ES-11
W20EXR-ZU	BPR6EIX
W20EX-U	BP6EY
W20EX-U11	BP6EY-11
W20EX-U13	BP6ES-11
W20EX-ZU	BPR6EIX
W20FP	BP6HS
W20FP-L	BPR6HSA
W20FPR	BPR6HS
W20FPR-L	BPR6HSA
W20FPR-U	BPR6HS
W20FPR-U10	BPR6HS-10
W20FPR-UL10	BPR6HS-10
W20FPR-ZU	BPR6HIX
W20FP-U	BP6HS
W20FPU10	BPM6A-10
W20FP-U10	BP6HS-10
W20FR-L	BR6HSA
W20FS	B6HS
W20FS-GU	BR6HIX
W20FSR	BR6HS
W20FSRU	BR6HS
W20FSR-U	BR6HS
W20FS-U	B6HS
W20FS-U10	B6HS-10
W20FS-ZU	BR6HIX
W20M	BM6A
W20MPRU	BPMR6A
W20MPR-U10	BPMR6A-10
W20MPU	BPMR6A
W20MP-U	BPM6A
W20MPU10	BPM6A-10
W20MP-U10	BPM6A-10
W20MR-U	BMR6A
W20M-U	BM6A
W20M-US	BM6A
W20PR-U	BP6S
W20P-U	BP6S



CROSS REFERENCE CHART SPARK PLUG



Note: NGK recommends to use the "Torch" part numbering system as a starting point when trying to cross "Chinese" manufacturing brands back to NGK.

Other Part No.	NGK Part No.	Other Part No.	NGK Part No.	Other Part No.	NGK Part No.
DENSO (CONT)					
W20S	B6S	W22FS-GU	BR7HIX	W24S-U	B8S
W20SR-U	BR6S	W22FSR	BR7HS	W25EA	BR8EM
W20S-U	B6S	W22FSR-U	BR7HS	W25EAR	BR8EM
W20TT	BPR6ES	W22FS-U	B7HS	W25EB	BR8ET
W21ES-L11	BR6EB-L-11	W22FS-ZU	BR7HIX	W25EBR	BR8ET
W21ESR-L11	BR6EB-L-11	W22M	BM7A	W25EDR	BR8EQ
W22	B7S	W22MPR-U	BPMR7A	W25EDR14	BR8EQ-14
W22EA	B7EM	W22MP-U	BPM7A	W25EN	B8EG
W22EAR	B7EM	W22MP-US	BPM7A	W25FC	B8HCS
W22EB	BR7ET	W22M-U	BM7A	W25FN	BR8HIX
W22EBR	BR7ET	W22M-US	BM7A	W27EBR	BR9ET
W22EDR14	BR7EQ-14	W22S	B7S	W27EDR	BR9EQ-14
W22EKR-S11	BUR7EB-11	W22S-U	B7S	W27EDR14	BR9EQ-14
W22EK-S11	BUR7EB-11	W24	B8S	W27EMR-C	BR9ECM
W22EP	BP7ES	W24EMR-C	BR8ECM	W27EMR-ZU	BR9ECMIX
W22EP11	BP7ES-11	W24EP	BP8ES	W27EN	B9EG
W22EPB	BR7ET	W24EPR	BPR8ES	W27EPT	BR9EIX
W22EP-GU	BPR7EIX	W24EPR-U	BPR8ES	W27ES	B9ES
W22EPR	BPR7ES	W24EPR-ZU	BPR8EIX	W27ES-C	B9ECS
W22EPR-U	BPR7ES	W24EP-U	BP8ES	W27ES-GU	BR9EIX
W22EPR-ZU	BPR7EIX	W24ES	B8ES	W27ESR	BR9ES
W22EPR-ZU11	BKR7EIX-11	W24ES-GU	BR8EIX	W27ESR-U	BR9ES
W22EP-U	BP7ES	W24ESR	BR8ES	W27ESR-V	BR9EG
W22EP-U11	BP7ES-11	W24ESR-U	BR8ES	W27ESR-ZU	BR9EIX
W22EP-ZU	BPR7EIX	W24ESR-V	BR8EG	W27ES-U	B9ES
W22ES	B7ES	W24ESR-ZU	BR8EIX	W27ES-V	B9EG
W22ES-GU	BR7EIX	W24ES-U	B8ES	W27ES-ZU	B9EGV
W22ES-L	B7ES	W24ES-U11	B8ES	W27FC	B9HCS
W22ES-L11	BUR7EB-11	W24ES-V	B8EG	W27FN	B9HVX
W22ESR	BR7ES	W24ES-ZU	B8EGV	W27FS	B9HS
W22ESR-L	BR7ES	W24FP	BP8HS	W27FS-GU	B9HVX
W22ESR-L11	BUR7EB-11	W24FPL	BP8HS	W27FSR	BR9HS
W22ESR-U	BR7ES	W24FPR	BPR8HS	W27FSRU10	BR9HS-10
W22ES-U	B7ES	W24FPRL	BPR8HS	W27FSR-U10	BR9HS-10
W22ES-U11	B7ES	W24FPR-U10	BPR8HS	W27FS-U	B9HS
W22ES-ZU	BR7EIX	W24FP-U	BP8HS	W27FS-U10	B9HS-10
W22EXR-U	BPR7ES	W24FR-L	BR8HSA	W27FS-ZU	B9HVX
W22EX-U	BP7EY	W24FS	B8HS	W29ES-GU	B95EGV
W22FP	BP7HS	W24FS-GU	BR8HIX	W29ESR-V	BR10EG
W22FPR	BPR7HS	W24FSR	BR8HS	W29ES-V	B10EG
W22FPR-U	BPR7HS	W24FSR-U10	BR8HS-10	W29ES-ZU	B10EVX
W22FPR-ZU	BPR7HIX	W24FS-U	B8HS	W31EMR-C	BR10ECM
W22FP-U	BP7HS	W24FSU10	B8HS-10	W31EMR-ZU	BR10ECMIX
W22FP-U10	BP7HS-10	W24FS-U10	B8HS-10	W31EN	B10EG
W22FP-US	BP7HS	W24FS-ZU	BR8HIX	W31EPT	B10EGP
W22FS	B7HS	W24MPR-U	BPMR8Y	W31ES	B10ES
		W24S	B8S	W31ES-GU	B10EGV

Note: NGK recommends to use the "Torch" part numbering system as a starting point when trying to cross "Chinese" manufacturing brands back to NGK.

Other Part No.	NGK Part No.
DENSO (CONT) 	
W31ESR-U	BR10ES
W31ESR-ZU	BR10EIX
W31ES-U	B10ES
W31ES-ZU	B10EVX
W31FS	B10HS
W31FS-U	B10HS
W31FS-ZU	BR10HIX
W32EPT	B105EGV
W34EN	B11EGV
W34EPT	B11EGV
W34E-ZU	B11EGV
W9	B-2
W9EP	BP-2E
W9EXR-U	BPR2ES
W9EX-U	BPR2ES
W9FP	C-2H
W9LMR-US	BR2-LM
W9LM-US	B2-LM
W9P	BP-4
W9PR-U	BP-4
W9PR-U15	B-2
W9P-U	BP-4
W9-U	B-2
WA20M	BM6F
WA22M	BM7F
X16EPR-U9	DPR5EA-9
X16EP-U9	DPR5EA-9
X16FSR-U	DR5HS
X16FS-U	DR5HS
X20EPR-U9	DPR6EA-9
X20EP-U9	DPR6EA-9
X20ESRU	D6EA
X20ESR-U	D6EA
X20ES-U	D6EA
X20FS-GU	D6HA
X20FSR-U	DR6HS
X20FS-U	D6HA
X22EPR-GL	PJR7A
X22EPR-U9	DPR7EA-9
X22EPR-ZU9	DPR7EIX-9
X22EP-U	DP7EA-9
X22EP-U9	DP7EA-9
X22EP-ZU9	DPR7EIX-9
X22ES-GU	D7EVX
X22ESR-U	DR7EA
X22ES-U	D7EA

Other Part No.	NGK Part No.
X22ES-ZU	D7EVX
X22GPR-U	DPR8Z
X24EPR-U9	DPR8EA-9
X24EPR-ZU9	DPR8EIX-9
X24EP-U	DP8EA-9
X24EP-U9	DP8EA-9
X24EP-ZU9	DPR8EIX-9
X24ES-GU	DR8EIX
X24ESR-U	DR8EA
X24ESR-ZU	DR8EIX
X24ESR-ZU9	DR8EIX
X24ES-U	D8EA
X24ES-ZU	DR8EIX
X24ES-ZU9	DR8EIX
X24FSR-U	DR8HS
X24FS-U	D8HA
X24FS-ZU	D8HA
X24GPR-U	DPR8Z
X24GP-U	DP8Z
X27EPR-U9	DPR9EA-9
X27EPR-ZU9	DPR9EIX-9
X27EP-U9	DP9EA-9
X27EP-ZU9	DPR9EIX-9
X27ESR-U	DR9EA
X27ESR-ZU	DR9EIX
X27ESR-ZU9	DR9EIX
X27ES-U	D9EA
X27ES-ZU	DR9EIX
X27ES-ZU9	DR9EIX
X27ET	J9A
X27ETR	JR9B
X27GPR-U	DPR9Z
X27GP-U	DPR9Z
X29ES-ZU	DR9EIX
X31ES-U	D10EA
XU20EPR-U	DCPR6E
XU20EPRZU	DCPR6E
XU20EP-U	DCPR6E
XU22EP-P	DCPR7EIX
XU22EPR	DCPR7E
XU22EPR-P	DCPR7EIX
XU22EPR-U	DCPR7E
XU22EPR-ZU	DCPR7EIX
XU22EP-U	DCP7E
XU22EP-ZU	DCPR7EIX
XU24EPR-P	DCPR8EIX
XU24EPR-U	DCPR8E

Other Part No.	NGK Part No.
XU24EPR-ZU	DCPR8EIX
XU24EP-U	DCPR8E
XU24EP-ZU	DCPR8EIX
XU27EPR-U	DCPR9E
XU27EPR-ZU	DCPR9EVX
Y24FER-C	ER8EH
Y27FER	ER9EH
Y27FER-C	ER9EH
Y31FER-C	ER10EH
Z20ES-U	D6EA
ZXU20PR11	IKR6G11
ZXU22PR11	IKR6G11
E3 	
E3.12	BMR7A
E3.16	BM6F
E3.20	BKR5E
E3.22	BPR6ES
E3.31	B8ES
E3.32	BR8HSA
E3.34	BPR5ES
E3.38	C7E
E3.40	BPR5FS
E3.42	BPR4FS
E3.44	BPR5EFS
E3.48	BKR6E
E3.52	BP5S
E3.53	TR6
E3.54	BPR5EFS-13
E3.56	BCPR6E
E3.58	FR5-1
E3.60	TR5-1
E3.64	BKR5E-11
E3.66	LZTR4A-11
E3.68	LFRA6A-11
EYQUEM 	
200	B-4H
406	B5HS
700	B6HS
750	BP6HS
755	B6HS
850	B7HS
1000	B8HS
1100	B9HS
1000CM	B7S
1000L	B8ES
1000M	B8HS
100M	B8HS





CROSS REFERENCE CHART SPARK PLUG





Note: NGK recommends to use the "Torch" part numbering system as a starting point when trying to cross "Chinese" manufacturing brands back to NGK.

Other Part No.	NGK Part No.	Other Part No.	NGK Part No.	Other Part No.	NGK Part No.
EYQUEM (CONT)					
1100L	B8ES	755 MOTO	B6HS	FC42LS	BKR5E
1150L	B9ES	755CJT	BM6F	FC52LS	BKR5E
300AM	B-4L	755CM	B6S	FC58LS	BKR6E
30AM	B-4L	755CT	BM6A	FC62LS	BKR6E
400J	BR5FS	755L	B6ES	FC62LS2	BKR6E
450JS	BPR4FS-15	755L MOTO	B6ES	FC62LS3	BCPR6ET
450L	B5ES	755LJS	BP6EFS	FC72LS	BCP7ES
480CS	BP5S	755LS	BP6ES	FC82LS1	BCP7ES
500AM	B-6L	755LS MOTO	BP6ES	FC82LS2	BCP7ES
500CJT	BM6F	755M	B6HS	K200M	AB-6
500CM	B6S	755S	BP6HS	K300JS	AP5FS
500CS	BP5S	75LM	B6ES	K300M	AB-6
500CT	BM6A	75M	B6HS	K350JS	AP5FS
500J	BR6FS	775SX	BP6HS	K450JS	AP5FS
500JS	BPR4FS	775X	B6HS	K500M	AB-6
500M	B5HS	800L	B6ES	K550JS	AP6FS
502 MOTO	B-4H	800LJS	BP6EFS	K600M	AB-6
505JS	BP5FS	800LS	BP6ES	K750M	AB-7
50AM	B-6L	800LS MOTO	BP6ES	RC52LS	BPR5ES
50M	B5HS	802L	B6ES	RC58LZ3EX	BUR6ET
520CS	BP5S	803LJS	BP6EFS	RC62HJSDP	PTR5A-13
550CS	BP5S	805L	B6ES	RC62LS	BPR6ES
550JS	BPR5FS	805L MOTO	B6ES	RC72LS	BPR7ES
550LS	BP5ES	805LJS	BP7EFS	RFC42LS2E	BKR5EK
550S	BP4HS	805LP	BR7EIX	RFC42LZ2E	BKR6EK
580LS	BP5ES	850 MOTO	B7HS	RFC50LZ2E	BKR5EK
580S	BP4HS	850LS	BP7ES	RFC52LS	BKR5E
600CS	BP5S	C32S	BP5HS	RFC52LS5	BKR5E-11
600JS	BPR6FS	C42S	BP6HS	RFC52LZ3EX	BKUR5ET
600L	B6ES	C52LS	BP5ES	RFC52LZE	ZFR5F
600LS	BP6ES	C62	BR6HSA	RFC58LS2E	BKR6EK
600S	BP5HS	C62LJS	BP6EFS	RFC58LS3	BCPR6ET
700 MOTO	B6HS	C62LS	BP6ES	RFC58LZ2	BKR6EKC
700CM	B6S	C62LS3X	BUR6ET	RFC58LZ2E	BKR6EK
700CTS	BPM6A	C72LJS	BP7EFS	RFC58LZ3EX	BKUR6ET-10
705JS	BP7FS	C82LJS	BP7EFS	RFC58LZDP	PFR6G-9
705L	B6ES	C82LS	BP7ES	RFC58LZE5	ZFR6F-11
705L MOTO	B6ES	C92LS	BP8ES	RFC62LS3	BKR6E-11
705S	BP6HS	D1000	D8HA	RFC62LS3X	BCPR6ET
705S MOBY MOTO	B5HS	D1000 MOTO	D8HA	RFC82LS5	BKR7E-11
707LS	BP6ES	D1000L	D9EA	RFCLZ3X	BKUR7ET
70M	B6HS	D1050L	D9EA	RFN58HZ	LF6A
750L	B6ES	D755 MOTO	D6HA	RFN58LZ	BKR6EZ
750LJS	BP6EFS	D775	D6HA	T850	C6HSA
750LS	BP6ES	D800L	D7EA	GATOR	
753LJS	BP6EFS	D800L MOTO	D7EA	77-302	BM4A
		D900L	D7EA		

Note: NGK recommends to use the "Torch" part numbering system as a starting point when trying to cross "Chinese" manufacturing brands back to NGK.

Other Part No.	NGK Part No.
HARLEY DAVIDSON 	
EVS13P	BPR6ES-11
EVS13S	BPR5ES-11
EX12P	DCPR8E
EX12S	DCPR7E
HD10R12	DCPR8E
HD10R12A	DCPR8E
HD2	B-6L
HD3	B-6L
HD3-4	R5670-7
HD4	B-6L
HD4A	B-6L
HD4R	B-6L
HD4R5	BPR6HS
HD4R5G	BPR6HS
HD5	BR6S
HD5-A6	BPR5ES-11
HD5A6A	BPR5ES-11
HD5R6	BPR5ES-11
HD5R6A	BPR5ES-11
HD6	B7ES
HD6R12	DCPR7E
HD6R12	DCPR7EIX
HD6RL	BP7ES
HD7	B8ES
HD7-8	BR9ES
HD8	B10EG
SH13S	BPR5EY-11
X12P	DCPR7E
XL10S	BPR6HS-10
HITACHI 	
43W	B8S
44W	B7S
45-PW	BP6S
45W	B6S
46W	B-4
47-PW	BP-4
47W	B-2
84S	AB-7
84VP	AP7FS
84W	AB-7
85S	AB-6
85W	AB-6
86	AB-2
86V	A6FS
86VP	AP6FS
86-VPW	AP6FS

Other Part No.	NGK Part No.
86-VW	A6FS
87VP	AP4FS
87-VPW	AP5FS
C45W	BM7A
C46W	BM6A
L13W	C7HSA
L14W	C6HSA
L16W	CR4HSA
L23W	D8EA
L24W	D7EA
L41W	B10ES
L42-PW	BP9ES
L42W	B9ES
L43-PW	BP8ES
L43W	B8ES
L44-PW	BP7ES
L44PW-11	BP7ES-11
L44-PW-11	BP7ES-11
L44W	B7ES
L44X	B7ES
L45B	B6ES
L45-PA	BP5EY
L45-PW	BP6ES
L45-PW-11	BP6ES-11
L45-PX	BP6ES
L45S	BC6ES
L45W	B6ES
L45X	B6ES
L46B	B5ES
L46-PA	BP4EY
L46PW	BP5ES
L46-PW	BP5ES
L46-PW-11	BP5ES-11
L46-PW-13	BPR5ES-13
L46-PX	BP5ES
L46W	B5ES
L46X	B5ES
L47-PW	BP4ES
L47-PX	BP4ES
L47W	B4ES
M23W	D8HA
M24PW	D6HA
M24W	D6HA
M42W	B9HS
M43W	B8HS
M44-PW	BP7HS
M44-VPW	BP7FS

Other Part No.	NGK Part No.
M44W	B7HS
M44X	B7HS
M45-PW	BP6HS
M45-PX	BP6HS
M45-VPW	BP6FS
M45W	B6HS
M45X	B6HS
M46-PW	BP5HS
M46-PX	BP5HS
M46-VPW	BP5FS
M46W	B-4H
M46X	B5HS
M47-PW	BP4HS
RL45-PW	BPR6ES
RL45-PX	BPR6ES
RL46-PW	BPR5ES
RL46-PX	BPR5ES
RL47-PX	BPR4ES
ISKRA 	
FE65PRS	BPR5ES
FE65PS	BP6ES
SFE55PRS	BKR5E
SFE65PRS	BKR6E
IVP 	
BP6C	BP4HS
BV	B5HS
K&N 	
XP422	PFR6G-11
KLG 	
F100	B8HS
F20	B-4H
F220	B9HS
F50	B5HS
F55P	BP5HS
F65P	BP6HS
F70	B5HS
F75	B6HS
F80	B7HS
F85P	BP6HS
F95P	BP7HS
FA50	B-4L
FA70	B-6L
FE100	B8ES
FE125P	BP6ES
FE135P	BP7ES
FE145P	BP8ES
FE155P	BP8ES





CROSS REFERENCE CHART SPARK PLUG

Note: NGK recommends to use the "Torch" part numbering system as a starting point when trying to cross "Chinese" manufacturing brands back to NGK.

Other Part No.	NGK Part No.	Other Part No.	NGK Part No.	Other Part No.	NGK Part No.
KLG (CONT)					
FE20	B4ES	MT55P	AP6FS	BAN	B-4
FE220	B9ES	MT65P	AP6FS	BANY	BP5S
FE30	B4ES	MT70T	A6FS	BBANY	BP-4
FE45P	BP5ES	MT75P	AP6FS	BBL	AB-6
FE50	B5ES	MT85P	AP6FS	BBNY	BP-4H
FE55P	BP5ES	SM30	AB-6	BL14	B4ES
FE65P	BP6ES	SM50	AB-6	BLN	B4ES
FE70	B5ES	SM80	AB-7	BLNY	BP5ES
FE75	B6ES	T90	C7HSA	BLTY	BPR5EFS
FE80	B7ES	TENL100	C8HSA	BN	B-4H
FE85P	BP6ES	TENL30	C6HSA	BNY	BP-4H
FE95P	BP7ES	TW270	D6HA	BTNY	AP5FS
FS20	B-2	TW275	D6HA	B-TY	BP5FS
FS30	B-4	TW280	D8HA	BV	AB-2
FS35P	BP-4	TWE270	D8EA	C14	B5HS
FS45P	BP5S	TWE275	D9EA	CAN	B6S
FS50	B6S	LODGE		CANB	BPM6A
FS50-2	B6S	2BTNY	AP5FS	CANC	BM6A
FS55P	BP6S	2H	B7HS	CANY	BP6S
FS60T	B6S	2H12	D8HA	CC14	B6HS
FS70	B6S	2HA	B6S	CL10	C6HSA
FS70T	B6S	2HAN	B8S	CL14	B5ES
FS75	B7S	2HL	B7ES	CLN	B6ES
FS75H	B7S	2HL10	C7HSA	CLN14P	B5ES
FS80-2	B8S	2HLD	BKR6E	CLNH	B5ES
FT55P	BP5FS	2HL-E	B7ES	CLNY	BP5ES
FT65P	BP5FS	2HLN	B7ES	CN	B5HS
FT85P	BP6FS	2HLNY	BP7ES	CNY	BP5HS
FT95P	BP7FS	2HN	B7HS	CSN	B-4L
GT4S	BP5S	2HNY	BP7HS	CTNY	AP5FS
GT4T	AP5FS	2H-TNY	AP7FS	CTY	BP5FS
GT5	BP5HS	2HTY	BP6FS	CV	AB-6
GT5L	BP5ES	2HV	AB-8	H	B6HS
GT5T	AP5FS	2XL	BP6ES	H12	D6HA
GT6	BP6HS	3B-TY	BP4FS	H14	B7HS
GT6L	BP6ES	3HAN	B8S	H18	AB-7
GT6T	AP6FS	3HLN	B8ES	HA	B7S
GT7	BP7HS	3HLNY	BP7ES	HAN	B7S
GT7L	BP7ES	3HN	B8HS	HAN/M	B7S
GT8L	BP8ES	3HNY	BP8ES	HB12	D6HA
M30	AB-2	4HLNY	BP8ES	HBAN	B6S
M50	AB-6	5HLNY	BP8ES	HBL12	D8EA
M60	AB-6	15HLNY	BP6ES	HBLN	B5ES
M75	AB-7	25HL	BPR7ES	HBN	B5HS
M80	AB-8	25HLD	BCPR6ET	HBSN	B-6L
MT45P	AP5FS	25HLNY	BP7ES	HBTNY	AP6FS
		25XL	BP6ES	HBTY	BP5FS

Note: NGK recommends to use the "Torch" part numbering system as a starting point when trying to cross "Chinese" manufacturing brands back to NGK.

Other Part No.	NGK Part No.
LODGE (CONT) 	
HBV	AB-6
HF2HL	B8ES
HH14	B9HS
HL	B6ES
HL12	D9EA
HL14	B6ES
HL-E	B6ES
HLN	B6ES
HLNP	B6ES
HLNY	BP6ES
HN	B6HS
HN14	B7HS
HNY	BP6HS
HT14	BP5FS
HT18	AP6FS
HTN	A6FS
HTN18	A7FS
HTNY	AP6FS
H-TY	BP6FS
HV	AB-7
MARCHAL/VALEO 	
35	B6HS
36	B5HS
2/32	B8HS
2/33	B8HS
2/13	AB-8
17C	AB-7
19C	AB-7
19E	AB-7
19L	AB-7
2/32H	B8ES
2/33H	B7ES
20C	AB-6
20E	AB-7
20L	AB-7
21C	AB-6
21E	AB-6
21L	AB-6
22L	AB-2
22LM	AB-2
23F	A6FS
32LM	AB-2
34/5HS	BP6ES
34C	B7S
34CM	B7S
34HS	B7ES

Other Part No.	NGK Part No.
34HSM	B7ES
34S	B7HS
35/1	BP6HS
35/1B	BP6HS
35/1D	BP6HS
35/36D	B6HS
35/36P	B6HS
35/36R	B6HS
35B	B6HS
35C	B6S
35CM	B6S
35HA	BP6ES
35HS	B6ES
35M	B6HS
35P	B6HS
36B	B5HS
36C	B6S
36CM	B6S
36D	B5HS
36HS	B5ES
36M	B5HS
36P	B5HS
37S	B5HS
4N	B7HS
5H	B7ES
5N	BP6HS
5N CYCLO	BP6HS
64H	BP7ES
6H	BP7ES
6N	BP5HS
70H	BP6ES
76H	BP5ES
7H	BP6ES
84H	BP5ES
88N	B5HS
8H	BP6ES
9H	BP5ES
C64H	BP6EFS
C68H	BP6EFS
C7H	BP6EFS
F70H	BCP7ES
F74H	BKR6E
F80H	BCP7ES
GT34	BP7HS
GT34/2H	BP6ES
GT34/5	BP6HS
GT34/5D	BP6HS

Other Part No.	NGK Part No.
GT34/5H	BP6ES
GT34/5HA	BP6ES
GT34/5HD	BP6ES
GT34D	BP7HS
GT34H	BP7ES
GT34HD	BP6ES
GT35	BP5HS
GT35D	BP5HS
GT35H	BP5ES
GT35HD	BP5ES
H32RG	B9EG
H33RG	B8EG
H34F	B8ES
HA32/2	B8ES
HA32RS	B9EG
HF34	B7ES
HF34F	B8ES
RR31HS	B10EG
RR32HS	B9EGV
RR33HSS	B8EGV
SCGT34/5H	BP6EFS
SCGT35H	BP6EFS
V36A	B5HS
V6N SOLEX	B5HS
MARELLI 	
7LCR	BKR6E
7LPR	BKR6E
8LCR	BKR7E
8LPR	BKR7E
AW56C	BM7A
AW5C	BM6A
CM1N	AB-2
CM2N	AB-2
CM3N	AB-6
CM4N	AB-6
CM5N	AB-6
CM6N	AB-7
CU7N	C7HSA
CW101L	B85EGV
CW10L	B8EG
CW112L	B9EG
CW11L	B9EG
CW12L	B9EG
CW12NV	BUH
CW13L	B10EG
CW14L	B10EG
CW25N	B-4H





CROSS REFERENCE CHART SPARK PLUG

Note: NGK recommends to use the "Torch" part numbering system as a starting point when trying to cross "Chinese" manufacturing brands back to NGK.

Other Part No.	NGK Part No.	Other Part No.	NGK Part No.	Other Part No.	NGK Part No.
MARELLI (CONT)					
CW2C	B-2	CW6N	B6HS	CWP8L	BR7EIX
CW2CJ	B-2	CW6NE	BM6A	CWP8N	BR7HIX
CW2L	B4ES	CW6NJ	B6HS	CX6N	D6HA
CW2N	B-4H	CW6NP	BP6HS	CX8L	D8EA
CW3C	B-4	CW6NPR	BPR6HS	CX8N	D8HA
CW3CJ	B-4	CW6NR	BR6HS	DW4CJR	BR6S
CW3CP	BP-4	CW75LP	BP6ES	F6NC	BP5HS
CW3L	B4ES	CW78L	B6ES	F6NCR	BPR5HS
CW3N	B-4H	CW78LP	BP6ES	F7LC	BP6ES
CW4A	B5ES	CW78LPR	BPR6ES	F7LCR	BPR6ES
CW4C	B-4	CW78LPS	BP6ES	F7NC	BP6HS
CW4CJ	B-4	CW7C	B6S	F7NCR	BPR6HS
CW4CP	BP-4	CW7L	B6ES	F8LC	BP7ES
CW4L	B4ES	CW7LCR	BKR6E	F8LCR	BPR7ES
CW4LP	BP4ES	CW7LJ	B6ES	FC6N	B5HS
CW4N	B-4H	CW7LP	BP6ES	FC7N	B6HS
CW4NJ	B-4H	CW7LPH	BP6ES	FC9L	BP8ES
CW55N	B5HS	CW7LPR	BPR6ES	SW5C	BM6F
CW5C	B-4	CW7LR	BR6ES	T7LC	BP6EFS
CW5CP	BP5S	CW7N	B6HS	T7LCR	BPR6EFS
CW5L	B5ES	CW7NJ	B6HS	T8LC	BP7EFS
CW5LJ	B5ES	CW7NP	BP6HS	TM2NP	AP5FS
CW5LP	BP5ES	CW7NPR	BPR6HS	TM4NP	AP6FS
CW5LS	B5ES	CW7NR	BR6HS	TW4LP	BP5EFS
CW5LSZ	B5ES	CW89LP	BP7ES	TW5NP	BP5FS
CW5N	B5HS	CW8CJ	B7S	TW6NP	BP6FS
CW5NJ	B5HS	CW8L	B7ES	TW78LP	BP6EFS
CW5NP	BP5HS	CW8LCR	BKR7E	TW78LPR	BPR6EFS
CW5NR	BR5HS	CW8LJ	B7ES	TW78NPR	BPR6FS
CW5NS	B5HS	CW8LP	BP7ES	TW7LP	BP6EFS
CW5NSZ	B5HS	CW8LPR	BPR7ES	TW7LPR	BPR6EFS
CW67L	B6ES	CW8LPS	BP7ES	TW7NP	BP6FS
CW67LP	BP6ES	CW8N	B7HS	MERCURY/MERCURISER	
CW67N	BP6HS	CW8NP	BP7HS	33- 12127	BP6HS-10
CW67NJ	B6HS	CW8NR	BR7HS	33- 13686Q	BU8H
CW67NR	BR6HS	CW9L	B8ES	33- 14103550	BUZHW
CW67P	BP5ES	CW9LJ	B8ES	33- 14103568	BUZ8H
CW6C	B6S	CW9LP	BP8ES	33- 14103Q	BUZHW-2
CW6CE	BM6A	CW9N	B8HS	33- 14814568	BPZ8HS-15
CW6CJ	B6S	CWC12NJ	B8HS	33- 14814Q	BPZ8HS-10
CW6L	B5ES	CWC67NJ	B6HS	33- 17719547	BPR7HS-10
CW6LJ	B5ES	CWC6NJ	B6HS	33- 19424	BP8HS-15
CW6LP	BP5ES	CWC7NJ	B6HS	33- 19796	BPR6HS-10
CW6LR	BR5ES	CWC9NJ	B7HS	33- 41263M	B7HS-10
CW6LS	B5ES	CWP10N	B9HVX	33- 82370M 1	B6HS
CW6LSZ	B5ES	CWP11L	B10EGV	33- 82371M	B7HS
		CWP7L	B6EVX	33- 82372M	B8HS

Note: NGK recommends to use the "Torch" part numbering system as a starting point when trying to cross "Chinese" manufacturing brands back to NGK.

Other Part No.	NGK Part No.
MERCURY/MERCUISER	
33- 84675M	B5HS
33- 941	BR8HS
33- 97180Q	BUHW
33- 97182Q	BUHW-2
33- 97184	BP7HS-10
33- 97186	B9HS-10
33- 97389	BPR6FS
33-803507	DCPR6E
33-803991	BR6FVX
33-810883	BPR6ES
33-813413	B7S
33-813415	B8S
33-813418	BR9HS-10
33-813421 4	R5673-8
33-813425	AR6FS
33-813469	B6S
33-813471 1	BR6ES
33-813472	BR6HS
33-816336Q	BPR6EFS
33-816737Q	BP8H-N-10
33-816837Q	BPZ8H-N-10
33-824406 8	BR8HS-10
33-827858Q	DPR6EA-9
33-827859	CR6HSA
33-828942	BR7HS-10
33-843220Q	IZFR6J
33-859495Q	LFR5A-11
33-862029	TR5IX
33-863622001	PZTR5A-15
33-881284Q	LFR6A-11
33-883323001	DCPR7E
33-889246Q39	ILFR6G-E
33-889597Q	IZFR5G
33-892567Q	IZFR5J
33-896323	B7HS
33-896329818	BR9ES
33-896329874	BR7HS
33-898264001	BR6FS
33-898829001	LFR4A-E
33-8M0046007	TR5IX
33-8M0057936	ZFR5F
33-8M2018369	ITR4A15
MICO 	
WR5BC	BPR6HS
WR6BC	BPR6HS

Other Part No.	NGK Part No.
MOTORCRAFT 	
1Y00	BPR5ES
1Y01	BPR6ES
1Y03	BPR5ES-11
1Y06	BKR5E
1Y07	BKR6E
1Y09	BKR5E-11
1Y0A	BKR6E-11
1Y0B	BKR7E-11
1Y0F	DCPR7E
1Y0G	ZFR5F-11
1Y0H	ZFR6F-11
1Y0K	BPR5ES-13
1Y0L	BRE527Y-11
1YR7	BKR6EIX-P
A1	B8S
A11	B-2
A11LM	B2-LM
A11NX	BM4A
A11U	B-2
A11X	B-2
A12	R5670-7
A1C	B8S
A1CU	B8S
A1X	B8S
A2	B7S
A21X	B8S
A22	BP6S
A22CU	BP6S
A22NX	BPM7A
A2C	B7S
A2NX	BM7A
A2X	B7S
A3	B6S
A32	BP6S
A3C	B6S
A3CU	B6S
A3NX	BM6A
A3X	B6S
A4	B6S
A42	BP5S
A42CU	BP5S
A5	B6S
A52	BP5S
A52CU	BP5S
A5C	B6S
A5CU	B6S

Other Part No.	NGK Part No.
A5NX	BM6F
A5X	B6S
A7	B-4
A7CLM	B4-LM
A7CX	B-4
A7LM	B4-LM
A7N	BM6A
A7NU	BM6A
A7NX	BM6A
A7U	B-4
A7X	B-4
A82	BP-4
A9	B-4
A901	B8S
A9X	B-4
AE1C	B7HS
AE1X	B7HS
AE2	B7HS
AE22	BP6HS
AE22C	BP6HS
AE2C	B7HS
AE2X	B7HS
AE3	B6HS
AE32	BP6HS
AE32C	BP6HS
AE3C	B6HS
AE3X	B6HS
AE4	B5HS
AE42	BP5HS
AE42C	BP5HS
AE4X	B5HS
AE52	BP5HS
AE6	B5HS
AE62	BP5HS
AE7	B-4H
AE8	B-4H
AE901	B9HS
AE901X	B9HS-10
AE91	B9HS
AE92	BP-4H
AER2X	BR7HS
AER32	BPR6HS
AER4	BR5HS
AER4X	BR5HS
AES4C	B5HS
AF1	R5673-8
AF12	BP7FS



CROSS REFERENCE CHART SPARK PLUG

Note: NGK recommends to use the "Torch" part numbering system as a starting point when trying to cross "Chinese" manufacturing brands back to NGK.

Other Part No.	NGK Part No.	Other Part No.	NGK Part No.	Other Part No.	NGK Part No.
MOTORCRAFT (CONT) NGK		AG42C	BP5ES	AGR22C	BPR6ES
AF-2	B7FS	AG42CU	BP5ES	AGR22CU	BPR6ES
AF22	BP6FS	AG44	ZGR5C	AGR2C	BR7ES
AF2C	R5673-7	AG44CU	BP5EY	AGR2X	BR7ES
AF-3	BR6FS	AG5	B5ES	AGR31	BR6ES
AF32	BP6FS	AG501	B10ES	AGR32	BPR6ES
AF3C	R5673-6	AG501X	B10EGV	AGR32C	BPR6ES
AF3NX	BM7F	AG52	BP5ES	AGR32CU	BPR6ES
AF42	BP5FS	AG52C	BP4ES	AGR34CU	BPR6EY
AF42C	BPR4FS	AG54	ZGR5C	AGR3X	BR6ES
AF501	R5673-10	AG54CU	BP4EY	AGR41	BR5ES
AF52	BP4FS	AG5C	B4ES	AGR42	BPR5ES
AF52C	BPR4FS	AG5CU	B5ES	AGR42C	BPR5ES
AF5NX	BM6F	AG603	BR9EIX	AGR42CU	BPR5ES
AF701	R5673-9	AG603C	BR9EIX	AGR44C	BPR5EA-L
AF902	R5674-8	AG7	B5ES	AGR44CU	BPR5EY
AG1	B8ES	AG701	B9ES	AGR44CU-11	BPR5EY-11
AG12	BP7ES	AG701C	B9ES	AGR47CU11	ZGR5B-11
AG12C	BP7ES	AG701CU	B9ES	AGR51	BR5ES
AG12CU	BP7ES	AG701X	B9EGV	AGR52	BPR5ES
AG1C	B8ES	AG82	BP4ES	AGR54CU	BPR4EY
AG1X	B8ES	AG9	B4ES	AGR701X	BR9EIX
AG2	B7ES	AG901	B9ES	AGR82	BPR4ES
AG203	B11EGV	AG901C	B9ES	AGR901X	BR8EIX
AG22	BP6ES	AG901CU	B9ES	AGRF22	BPR6EFS
AG22-4	BP6ES-11	AG901X	B8EGV	AGRF22-6	BPR6EFS-13
AG22C	BP6ES	AG902	BP8ES	AGRF22C	BPR6EFS
AG22CU	BP6ES	AG903	B8EG	AGRF32	BPR6EFS
AG23	B7ECS	AG92C	B8ES	AGRF32-6	BPR6EFS-13
AG252	BP6ES	AG9U	B4ES	AGRF42	BPR5EFS
AG252C	BP6ES	AGF12	BP7EFS	AGRF52	BPR5EFS
AG25C	B7EM	AGF12C	BP7EFS	AGRP52	ZFR4F-11
AG2C	B7ES	AGF22C	BP6EFS	AGS081C	BR8EQ-14
AG2CU	B7ES	AGF32C	BPR5EFS	AGS12C	BPR7ES
AG2X	B7ES	AGF32CU	BP6EFS	AGS22C	BPR6ES
AG3	B6ES	AGFS22FE13J	PTR6F-13	AGS2C	B7ES
AG32A	BP6ES	AGN42	BP5ES	AGS32C	BPR5ES
AG32C	BP6ES	AGP12C	BGP7ES	AGS32C-11	BPR5ES-11
AG32CU	BP6ES	AGP22C	BGP6ES	AGS3C	B6ES
AG34CU	BP6EY	AGPR12C	BKR7E	AGS42C	BPR4ES
AG34CU11	BP6EY-11	AGPR22C	BKR6E	AGS42CC	BPR4ES
AG3C	B6ES	AGPR32C	BKR6E	AGS44	ZGR5C
AG3X	B6ES	AGR12C	BPR7ES	AGS4C	B5ES
AG4	B5ES	AGR16C	BR8ET	AGS52C	BPR4ES
AG403	B10EGP	AGR1X	BR8ES	AGSF12C	BPR6EFS
AG403C	B10EGP	AGR21	BR6ES	AGSF12FM1	BPR7EFS-15
AG42	BP5ES	AGR22	BPR6ES	AGSF2	BPR6EFS

Note: NGK recommends to use the "Torch" part numbering system as a starting point when trying to cross "Chinese" manufacturing brands back to NGK.

Other Part No.	NGK Part No.
MOTORCRAFT (CONT) 	
AGSF22C	BPR5EFS
AGSF22FM1	BPR5EFVX
AGSF22PGM	PTR6F-13
AGSF22PM	PTR6F-13
AGSF22PP	PTR6F-13
AGSF22PPM	PTR6F-13
AGSF22WM	TR55IX
AGSF23C	BPR5EFS-13
AGSF24C	TR5-11X
AGSF24N	TR55-1
AGSF32C	BPR5EFS
AGSF32FEM	PTR5D-10
AGSF32FM	PTR5C-13
AGSF32PM	PTR5C-13
AGSF32W	TR55IX
AGSF32WWM	TR55IX
AGSF33C	TR4
AGSF34C	TR5-11X
AGSF34EE	TR5-11X
AGSF34PP	TR5-11X
AGSF42C-6	BPR5EFS-13
AGSF52C	TR4
AGSP22YE13	IFR6T11
AGSP32	BKR6E-11
AGSP32C	BKR6E-11
AGSP32FP	PFR5G-11
AGSP32FPM	PFR5G-11
AGSP32P	BKR6EIX-11
AGSP32PP	PFR5G-11
AGSP32PR	PFR6B-11
AGSP33C	ZFR6F-11
AGSP52	BKR5E
AGSP52C	BKR5E-11
AGSP54	ZFR5A-11
AL11	B-4L
AL5	B-6L
AL5X	B-6L
AL7	B-6L
AL7C	B-6L
AL7U	B-6L
AL7X	B-6L
AL82	B-6L
AL9	B-4L
AL9X	B-4L
AR21X	BR6S
AR31	BR6S

Other Part No.	NGK Part No.
AR32	BP6S
AR41	BR6S
AR42	BP5S
AR51	BR6S
AR52	BP5S
AR5S	BP-4
AR7N	BMR6A
AR82	BP-4
ARF2	BR6FS
ARF22	BPR6FS
ARF22C	BPR6FS
ARF22CU	BPR6FS
ARF2-6	BR6FS-15
ARF3	BR6FS
ARF32	BPR6FS
ARF32-6	BPR6FS
ARF32C-6	BPR6FS
ARF32M	BPR6FS
ARF3-6	BR6FS-15
ARF4	BR5FS
ARF42	BPR5FS
ARF42-6	BPR5FS-15
ARF42-8	BPR4FS-15
ARF42C	BPR4FS
ARF42CU	BPR5FS
ARF52	BPR4FS
ARF52-6	BPR4FS-15
ARF52-8	BPR4FS-15
ARF6	BR5FS
ARF62	BPR4FS
ARF62-6	BPR4FS-15
ARF8	BR5FS
AS42C	BP5S
AS4C	BP5S
AS52C	BP-4
AS8	BP-4
ASF22C	BPR6FS
ASF32	BPR6FS
ASF32C	BPR6FS
ASF32C-6	BPR5FS-15
ASF32CM	BPR6FS
ASF32M	BPR6FS
ASF32P	UR5IX
ASF3C	BPR5FS
ASF42	BPR5FS-11
ASF42-6C	BPR5FS-15
ASF42C	BPR5FS-11

Other Part No.	NGK Part No.
ASF42C-6	BPR4FS-15
ASF42C-7	BPR4FS-15
ASF4C	BPR4FS
ASF4C-6	BPR4FS-15
ASF52	BPR4FS
ASF52-6	BPR4FS-15
ASF52-7	BPR4FS-15
ASF52C	BPR4FS
ASF8	BR5FS
AT1	B8S
AT10	B-2
AT2	B7S
AT3	B6S
AT4	B6S
AT42	BP5S
AT42M	BP5S
AT4A	B6S
AT6	B6S
AT8	B-4
ATL3	B-6L
ATL4	B-6L
ATL8	B-4L
AV1X	B8HS
AV22C	BP6HS
AV22CU	BP6HS
AV2C	B7HS
AV2CU	B7HS
AV2X	B7HS
AV3C	B6HS
AV3CU	B6HS
AV4	B5HS
AV42	BP5HS
AV52	BP5HS
AV6	B-4H
AV6C	B-4H
AV6CU	B-4H
AV701C10	B9HS-10
AV701CU10	B9HS-10
AV82	BP-4H
AV901C	B9HS
AV901CU	B9HS
AV901X4	B9HS-10
AV901X-4	B9HS-10
AVKO	BUH
AVKOD	BUHW
AVZKO	BUHX
AVZKO	BUHX





CROSS REFERENCE CHART SPARK PLUG

Note: NGK recommends to use the "Torch" part numbering system as a starting point when trying to cross "Chinese" manufacturing brands back to NGK.

Other Part No.	NGK Part No.	Other Part No.	NGK Part No.	Other Part No.	NGK Part No.
MOTORCRAFT (CONT)		AZFS22PP	PTR5A-13	BSF31-4	AR6FS
AWRF32	BPR6EFS	AZFS32FE	PTR5A-13	BSF42C	APR5FS
AWRF32-5	BPR6EFS-13	B2	AB-8	BSF6	APR5FS
AWRF42	BPR5EFS	B2W	AB-8	BSF82	APR5FS
AWSF22C	BPR6EFS	B3W	AB-7	BSF82C	APR5FS
AWSF22E	TR6IX	B3X	AB-7	BSF92	APR5FS
AWSF22FM	TR5IX	B4	AB-7	BT10	AB-6
AWSF22FM1	TR5IX	B4X	AB-7	BT15	AB-2
AWSF22FS	TR5IX	B6	AB-6	BT2	AB-8
AWSF24C	TR5-1IX	B6W	AB-6	BT3	AB-7
AWSF32	BPR6EFS	B8	AB-6	BT4	AB-7
AWSF32C	BPR6EFS	B82	APR5FS	BT6	AB-6
AWSF32E	TR55IX	B8X	AB-6	BT8	AB-6
AWSF32EE	TR55IX	B9	AB-6	BT9	AB-6
AWSF32F	TR55IX	BF1	A7FS	BTF1	A7FS
AWSF32FM	TR5IX	BF12	AP8FS	BTF3	A6FS
AWSF32P	BPR5EFVX	BF22	AP6FS	BTF31	A6FS
AWSF32PM	BPR5EFVX	BF22C	AP6FS	BTF42	AP5FS
AWSF32PP	TR5IX	BF22CU	AP6FS	BTF6	A6FS
AWSF34	TR5-1IX	BF22CX	AP6FS	BTRF42	APR5FS
AWSF34C	TR5-1IX	BF22X	AP6FS	BZ8	AB-6
AWSF34PP	TR5-1IX	BF3	A6FS	CYFS12F-3	ILTR6F9
AWSF42	BPR5EFS	BF32	AP6FS	HE2	D8HA
AWSF42C	BPR5EFS	BF32C	APR5FS	HE3	D6HA
AWSF42EE	TR55IX	BF32CU	AP6FS	HG2	D8EA
AWSF42P	TR5IX	BF32CX	AP6FS	HG22	D8EA
AWSF42PP	TR5IX	BF32X	AP6FS	HG22C	D8EA
AWSF44	TR5-1	BF42	AP5FS	HG2C	D8EA
AWSF44C	TR5-1IX	BF42C	APR5FS	HG2CU	D8EA
AWSF44EE	TR5-1IX	BF42CU	AP5FS	HGR2C	DR8EA
AWSF44P	TR5-1IX	BF601	A9FS	HV2	D8HA
AWSF44PP	TR5-1IX	BF82	AP5FS	HV22	D6HA
AWSF52C	BPR5EFS	BF82C	APR5FS	HV3	D6HA
AWSF54	TR5-1	BF901	A8FS	PE3	C6HSA
AWSF54C	TR5-1	BF92	AP5FS	PV2	C7HSA
AWSFA12C	TR6	BR8	AB-6	PV3	C6HSA
AWSFA32C	BPR5EFS	BRF22	APR6FS	NHSPLD	
AX9	B-4	BRF22C	APR6FS	A7RTC	CR6HSA
AYFS22FE1J	PLTR6A-10G	BRF31	AR6FS	A7T	C7HSA
AYFS22FM	LTR6BP13	BRF31-4	AR6FS	A7TC	C7HSA
AYFS32CJ	TR5B-13	BRF32	APR6FS	B6REC	CPR6EA-9
AYRF22P	PTR5A-13	BRF3M	AR6FS	B7RC	CR7E
AZ2	B7S	BRF42	APR5FS	B8RC	CR8E
AZ3	B6S	BRF6	AR6FS	C6TC	D6HA
AZ9	B-4	BRF82	APR5FS	D7	D7EA
AZ901	B8S	BSF3	AR6FS	D8RTC	DR8EA
AZFS22FE	PTR5A-13	BSF31	AR6FS	D8T	D8EA

Note: NGK recommends to use the "Torch" part numbering system as a starting point when trying to cross "Chinese" manufacturing brands back to NGK.

Other Part No.	NGK Part No.
NHSPLD (CONT) 	
D8TC	D8EA
E5T	BP-4H
E6T	BP4HS
E6TC	BP4HS
E7C	B6HS
E7RTC	BPR6HS
E7TC	BP6HS
E7TJC	BP6ET
E8C	B7HS
E8TC	BP7HS
F5C	B4ES
F5T	BP4ES
F5TC	BP4ES
F6RTC	BPR5ES-11
F6TC	BP5ES
F7RTC	BPR6ES
F7TC	BP6ES
F7TJC	BP5ET
F8C	B7ES
F8TC	BP7ES
G3F	B-4
G3TC	BP-4
G5RC	BR6S
G6	B6S
H5	B6S
K6RTC	BKR5E-11
K7RTC	BKR6E-11
K7TJC	BCPR6ET
L5C	BM4A
L5T	BPM4A
L6	BM6A
L6T	BPM6A
L7	BM7A
L7T	BPM7A
L7Y	BM7A
L8RT	BPMR7A
L9	BM7A
L9T	BPM7A
N6	BM6F
N9	BM7F
Q7TC	BP5EFS
R4C	AB-6
T5RTC	APR6FS
NST 	
A7TC	C6HSA

Other Part No.	NGK Part No.
PAL 	
14-5	B-4H
18-5	AB-6
14-7	B5HS
18-7	AB-7
14-8	B6HS
14-9	B8HS
17-9	B7HS
14-5Y	BP-4H
14-7Y	BP5HS
14-8R	BR6HS
14-8Y	BP6HS
14-9R	BR7HS
14-9Y	BP7HS
14K-5	B-4
14K-5Y	BP-4
14K-7Y	BP5S
14K-8	B6S
14L-5	B5ES
14L-5R	BR5ES
14L-5Y	BP5ES
14L-7	B6ES
14L-7R	BR6ES
14L-7Y	BP6ES
14L-8	B6ES
14L-8Y	BP6ES
14L-9	B7ES
14L-9Y	BP7ES
18-5R	AB-6
18-8W	AB-8
L5Y	BP5ES
L7Y	BP6ES
L8	B6ES
L8Y	BP6ES
L9Y	BP7ES
N17	B-4H
N7	B6HS
N7Y	BP6HS
N8	B7HS
N8Y	BP7HS
S14L-13	B8EG
S14L-15	B9EG
S14L-17	B10EG
PRESTOLITE 	
14E1	B8HS
14E01	BUH
10E2	C7HSA

Other Part No.	NGK Part No.
12E2	D8HA
14E2	B7HS
10E3	C7HSA
12E3	D8HA
14E3	B6HS
14-3	B6S
18-3	AB-6
14-4	B6S
18-4	AB-6
14-5	B6S
14-7	B-4
18-8	AB-6
14-9	B-4
18-9	AB-6
18-10	AB-6
14-11	B-2
10E4	C6HSA
14E4	B5HS
14E6	B5HS
12E22	D6HA
14E22	BP7HS
14E32	BP6HS
12E42	D6HA
14E42	BP6HS
14E52	BP5HS
14E62	BP5HS
14E82	BP-4H
12G2	D8EA
12G3	D8EA
14-11N	BPM6A
14-11X	B-2
14-2X	B6S
14-32	BP6S
14-3N	BM7A
14-3X	B6S
14-42	BP5S
14-52	BP5S
14-5X	B6S
14-7N	BM6A
14-7X	B-4
14-82	BP-4
14-9X	B-4
14ER4	BR6HS
14ER6	BR6HS
14F22	BP6FS
14F32	BP6FS
14F3N	BM7F



CROSS REFERENCE CHART SPARK PLUG

Note: NGK recommends to use the "Torch" part numbering system as a starting point when trying to cross "Chinese" manufacturing brands back to NGK.

Other Part No.	NGK Part No.	Other Part No.	NGK Part No.	Other Part No.	NGK Part No.
PRESTOLITE (CONT)					
14F42	BP5FS	14RF52	BPR4FS	B8C	C8E
14F52	BPR4FS	14RF52-6	BPR4FS-15	B8RH	CR8EH-9
14F7N	BM6F	14RF52A	BPR4FS-15	C6RTC	D6HA
14G1	B8ES	14RF62	BPR4FS	C6TC	DR6HS
14G12	BP8ES	14RF62-6	BPR4FS-15	C7E	C7E
14G2	B7ES	14RF62A	BPR4FS-15	C7TC	DP7EA-9
14G22	BP6ES	18F22	AP6FS	C8C	D8HA
14G3	B6ES	18F3	A6FS	C8E	C8E
14G32	BP5ES	18F32	AP6FS	C9E	C9E
14G4	B6ES	18F42	AP5FS	CR7E	CR7E
14G42	BP5ES	18F6	A6FS	CR8E	CR8E
14G5	B5ES	18F82	AP5FS	CR9E	CR9E
14G52	BP5ES	18RF3	AR6FS	D7CA	D7EA
14G7	B5ES	18RF32	APR6FS	D7RC	D7EA
14G82	BP4ES	18RF42	APR6FS	D7RP	DR7EIX
14G902	BP8ES	18RF82	APR6FS	D7RTC	DPR7EA-9
14GF22	BP6EFS	RALLIART		D7RTP	DPR7EIX-9
14GR22	BPR6ES	RA20165N10	R2556B-10	D7TC	DP7EA-9
14GR32	BPR5ES	RAR7438N9P	R7438-9	D8C	D8EA
14GR4	BR6ES	SPLITFIRE		D8RC	DR8EA
14GR42	BPR5ES	SF406B	B9EGV	D8RP	DR8EIX
14GR52	BPR4ES	SF413B	D9EA	D8RTC	DPR8EA-9
14GR53	ZGR5C	SF419D	C6HSA	D8TC	DP8EA-9
14GR7	BR5ES	SF426C	BPR6ES	DK7RTC	DCPR7E
14GRF22	BPR6EFS	SF45F	B4-LM	DK7RTP	DCPR7EIX
14GRF32	BPR5EFS	TP430B	CR9E	E4RTC	BPR4HS
14GRF52	BPR5EFS	TAINO		E4TC	BP4HS
14L4	B-6L	L5YR	BPR5ES	E5RTC	BPR5HS
14L7	B-6L	TECKNICA		E5TC	BP5HS
14L9	B-4L	T12	BPR2ES	E6C	B6HS
14R3	BR6S	T15	BP5FS	E6RC	BR6HS
14R32	BP5S	T44	BP5EFS	E6RTC	BPR6HS
14R4	BR6S	T92	B-4H	E6RTP	BPR6HIX
14R42	BP5S	TORCH		E6TC	BP6HS
14R5	BR6S	5580	BP6ET	E7RTC	BPR7HS
14R52	BP-4	A5RTC	CR5HSA	E7RTP	BPR7HIX
14R53	BP-4	A6RTC	CR6HSA	E7TC	BP7HS
14R7N	BM6A	A6S	CM-6	E8C	B8HS
14R8	B6S	A6TC	C6HSA	E8RC	BR8HS
14RF22	BPR6FS	A7RC	CR7HSA	E8RTC	BPR8HS
14RF32	BPR5FS	A7RTC	CR7HSA	E8TC	BP8HS
14RF32-6	BPR5FS-15	A7TC	C7HSA	F5RF	BPR5EY
14RF32A	BPR5FS-15	A8RTC	CR8HSA	F5RTC	BPR5ES
14RF42	BPR5FS	A8TC	C8HSA	F5RTP	BPR5EIX
14RF42-6	BPR5FS-15	AC6RA	CMR6A	F5RTPP-11	BPR5EP-11
14RF42A	BPR5FS-15	AC7R	CMR7H	F5TC	BP5ES
		B7RD	CR7EK	F6C	B6ES

Note: NGK recommends to use the "Torch" part numbering system as a starting point when trying to cross "Chinese" manufacturing brands back to NGK.

Other Part No.	NGK Part No.
TORCH (CONT) 	
F6RF	BPR6EY
F6RTC	BPR6ES
F6RTI	BPR6EIX
F6RTJY	BUR6ET
F6RTP	BPR6EIX
F6T	BP6ES
F6TC	BP6ES
F7C	B7ES
F7RC	BR7ES
F7RTC	BPR7ES
F7RTJC	BP6ET
F7RTP	BPR7EIX
F7TC	BP7ES
F7TJC	BP6ET
F8C	B8ES
F8RC	BR8ES
F8RTC	BP8ES
F8TC	BPR8ES
G4C	B-4
G4LC	B4-LM
G4RC	B-4
G6C	B6S
G6RC	BR6S
GL4	B4-LM
GL4RC	BR4-LM
K4RTC3	ZFR5F
K5RF-11	BKR5E-11
K5RT2PP-11	BKR5EP-11
K5RT3PP-11	PZFR5F-11
K5RTC	BCPR5ES
K5RTC-11	BKR5ES-11
K5RTC5	ZFR5N
K5RTM	LFRA5A-11
K5RTP	BKR5EIX
K5RTPP-11	PFR5G-11
K5RTPPF-11	PFR5J-11
K5rTS	ZFR5P-G
K5RTSPP	PZFR5D-11
K5TC	BKR5ES-11
K6RD	BKR6EKC
K6RDY	BKR6EK
K6RF	BKR6E
K6RF-11	BKR6E-11
K6RT2PP-11	BKR6EP-11
K6RT3PP-11	PZFR6F-11
K6RTC	BKR5E-11

Other Part No.	NGK Part No.
K6RTC-11	BKR6ES-11
K6RTI	BKR6EIX
K6RTIP	IFR6T11
K6RTJC	BKUR6ET
K6RTJPP	PFR6W-TG
K6RTJY	BKUR6ET
K6RTPP	PFR6B
K6RTPPF-11	PFR6J-11
K6TC	BKR6ES-11
K6TJC	BKUR6ET
K7RT3PP-11	ZFR7F-11
K7TC	BKR7ES-11
KL6RTI	LZFR6AI
L4RC	BMR4A
L6C	BM6A
L6RC	BMR6A
L6RTC	BPMR6A
L6TC	BPM6A
L7RC	BMR7A
L7RTC	BPMR7A
L7TC	BPM7A
LDKRTPP	PLKR7A
LZFR6AI	LZFR6AI
N6C	BM6F
N6RC	BMR6F
N6RTC	BPMR6F
N6TC	BPM6F
N7C	BM7F
N7RC	BM7F
P5RTC	BPR5FS
P5TC	BP5FS
P6RC	BR6FS
P6RTC	BPR6FS
P6TC	BP6FS
P7RTC	BP7FS
P7TC	BP7FS
Q5RTC	BPR5EFS
Q5RTP-11	TR5IX
Q5TC	BP5EFS
Q6RTC	BPR6EFS
Q6RTP-11	TR6IX
Q6RTPP-13	PTR6D-13
Q6TC	BP6EFS
Q7RTP-11	TR7IX
QH5RTIP-13	ILTR5A-13G
QH5RTPP-13	PTR5A-13
R6C	AB-6

Other Part No.	NGK Part No.
T1137C	C7HSA
T5RTC	APR5FS
T5TC	AP5FS
T6RTC	APR6FS
T6TC	AP6FS
Z4C	B-4L
UNIPART/SUREFIRE 	
GSP130	B5ES
GSP131	BP5ES
GSP141	BP5ES
GSP151	BP6ES
GSP160	B6ES
GSP163	BP6ES
GSP171	BP6ES
GSP181	BP7ES
GSP191	BP8ES
GSP2004	ZFR6F-11
GSP2007	BKR6E
GSP244	BPR5ES
GSP263	BPR6ES
GSP264	BPR5ES
GSP281	BPR7ES
GSP30	B6S
GSP331	BP5EFS
GSP351	BP5EFS
GSP361	BP6EFS
GSP381	BP7EFS
GSP4154	AP6FS
GSP4266	B5HS
GSP4352	BP6ES
GSP4356	BP6HS
GSP4362	BP6ES
GSP4366	BP6HS
GSP4372	BP5ES
GSP4382	BP5ES
GSP4452	BPR7ES
GSP4462	BPR6ES
GSP4472	BPR5ES
GSP4552	BCP7ES
GSP4562	BKR6E
GSP4563	BP6EFS
GSP4573	BP5EFS
GSP461	BPR6EFS
GSP46515	PTR5A-13
GSP4652	BKR7E
GSP4662	BKR6E
GSP4663	BPR6EFS



CROSS REFERENCE CHART SPARK PLUG

Note: NGK recommends to use the "Torch" part numbering system as a starting point when trying to cross "Chinese" manufacturing brands back to NGK.

Other Part No.	NGK Part No.
UNIPART/SUREFIRE (CONT)	
GSP531	BP5HS
GSP540	B5HS
GSP541	BP6HS
GSP550	B6HS
GSP560	B7HS
GSP571	BP7HS
GSP634	BKR5E
GSP6356	BP6HS
GSP6382	BP5ES
GSP6452	BPR7ES
GSP6462	BPR6ES
GSP6468	BPR6ES-11
GSP6472	BPR5ES
GSP664	BKR6E
GSP665	BKR6E
GSP6651	PTR5A-13
GSP6652	BKR7E
GSP6658	BKR7E-11
GSP6663	BPR6EFS
GSP6668	BKR6E-11
GSP684	BKR7E
GSP685	BCP7ES
GSP761	BP6FS
GSP881	BPR6FS
GSP9652	PFR6J
GSP981	AP6FS
VOLVO PENTA	
3851857	BPR5EFS
3851859	BPR4FS
3851861	BPR4FS
3851868	TR4
3854399	BPR5EFS
3856759	BPR5EFS
ZAZS	
A17DBPM	BPR6ES

REFERENCE ONLY
APPLICATION GUIDE



DISCONTINUED & REPLACEMENT LIST SPARK PLUGS

() means inside part number is discontinued and replacement part number is listed.

– means NO replacement Spark Plug.
(AR5FS) = AR5FS is discontinued and NO replacement Spark Plug.

Discontinued No.	Replacement No.	Discontinued No.	Replacement No.	Discontinued No.	Replacement No.
2G	–	B8EM	BR8EM	BP6EJ	BPR6EY-11
A5FS	(AR5FS)	B8EMV	BR8ET	BP6EQ-13	BP6ES-11/BP6ES-13
A-6	AB-6	B8ES-11	B8ES	BP6EV	BPR6EV
A-7	AB-7	B8ET	BR8ET	BP6EVX	BPR6EIX
A7F	A7FS	B8EV	BR8EIX	BP6HK	BPR6HSA
A-8	AB-8	B-8HN	R5530-8	BP6HSA	BPR6HSA
A8F	A8FS	B8HV	BPR8HIX	BP6HV	BPR6HIX
A-8V	AB-8	B8HVX	BPR8HIX	BP6HVX	BPR6HIX
A9EFP	–	B9EGP	BR9EIX	BP7EFS-13	BP7EFS
A-9F	A9FS	B9EV	BR9EIX	BP7EQ-13	BP7ES-11
A-9V	AB-8	B9HV	B9HVX	BP7EV	BPR7EIX
AP7FVX	–	B9EVX	BR9EIX	BP7EVX	BPR7EIX
APR5FS	AP5FS	B-9HN	–	BP7HVX	BPR7HIX
APR5FS-11	AP5FS	B9S	–	BP8ES-11	BP8ES
APR5FS-15	AP5FS	BC9ECS	–	BP8EV	BPR8EIX
APR6F	AP6FS	BCP5EV	BCP5EVX	BP8EVX	BPR8EIX
AR5FS	–	BCP6E	BCPR6E	BP9EV	BPR9EIX
AU10EFP	–	BCP6EV	BCP6EVX	BP9HVX	–
B105EGP	–	BCP6EVX-11	BCPR6EVX-11	BPM4A-10	BPMR4A-10
B10EG	BR10EG	BCP7ET	BCPR7ET	BPM7	BPM7A
B-10H	B10HS	BCP7EV	BCP7EVX	BPR4ES-L-11	BPR5ES-11
B10HV	BR10HIX	BCPR4E-11	BCPR4ES-11	BPR4FS-20	BPR4FS-15
B10HVX	BR10HIX	BCPR4ES	BCPR4ES-11	BPR4S	BP-4
B4ES-11	B4ES	BCPR6ER	BKR6EK	BPR4S-15	BP-4
B4HS	BR4HS	BCPR7ER	BKR6EK	BPR4S-20	–
B4HV	B-4H	BCPR7EY-N-11	–	BPR5EF-13	BPR5EFS-13
B5EB	BR5ES	BCR8ES	–	BPR5EP-13	BPR5EP-11
B5EB-11	BUR5EB-11	BE527Y-11	BRE527Y-11	BPR5ES-15	BPR5ES-13
B5ES-11	B5ES	BK5EKU	BKR5EKU	BPR5ES-15	BPR5ES-13
B5FS	BR5FS	BKR5EVX	BKR5EIX	BPR5EV	BPR5EIX
B6EB	BR6ES	BKR5EVX-11	BKR5EIX-11	BPR5S	BP5S
B6EB-11	BUR6EB-11	BKR6EVX	BKR6EIX	BPR5S-15	BP5S
B6EB-L-11	BR6EB-L-11	BKR7EVX-11	BKR7EIX-11	BPR6ES-N-11	BPR6ES-11
B6EFS	BR6EF	BKR7EY-11	BKR7E-11	BPR6EV	BPR6EIX
B6EM	–	BM4A-10	BM4A	BPR6FS-10	BPR6FS
B6EMV	–	BMR7F	BM7F	BPR6FS-15	BPR6FS
B6ET	–	BP10ES	BPR10EVX	BPR6S	BP6S
B6FS	BR6FS	BP4EFS	TR4	BPR7EKN	BPR7EIX
B6HV	BR6HIX	BP5EJ	BPR5EY-11	BPR7ES-11	BPR7ES
B6HVX	BR6HIX	BP5EQ-13	(BP5ES-13)	BPR7EY	BPR7EIX
B7EB	BR7ES	BP5ES-13	BPR5ES-13	BPR9EVX	BPR9EIX
B7EMV	BR7ET	BP5ES-L	BP5EY	BPS-6E	–
B7ET	BR7ET	BP5EVX	BPR5EIX	BPZ7HS-10	–
B7EV	(B7EVX)	BP5HA	BP5HS	BPZ9H-N-10	–
B7EVX	BR7EIX	BP6EF-13	BP6EFS-13/BPR6EF-13	BR10ECMVX	BR10ECMIX
B7HV	(B7EVX)	BP6EF-13	BP6EFS-13	BR10ET	–
B8ECS	BR8ECS	BP6EF-13	BPR6EF-13	BR4ES-11	BR4ES

DISCONTINUED & REPLACEMENT LIST SPARK PLUGS



Discontinued No.	Replacement No.
BR5EB	BR5ES
BR5EB-11	BUR5EB-11
BR5ES-11	BR5ES
BR6EB	BR6ES
BR6EB-11	BUR6EB-11
BR6EB-L	BR7ES
BR7EB	BR7ES
BR7EQ	-
BR7EQ-14	-
BR7ES-11	BR7ES
BR7EVX	BR7EIX
BR8EV	BR8EIX
BR8EVX	BR8EIX
BR8HV	(BR8HVX)
BR8HVX	BR8HIX
BR9ECMVX	BR9ECMIX
BR9EV	BR9EIX
BR9EVX	BR9EIX
BU5EB-11	BUR5EB-11
BU6EB-11	BUR6EB-11
BU8ET-Q	BP8ES
BUE	-
BUEW	-
BZ8ES	BR8ES
BZ9ES	BR9ES
BZ9EV	BR9EIX
C-10H	-
C-12H	-
C-13H	-
C-14H	-
C5HA	CR5HSA
C5HSA	CR5HSA
C-6M	C6HSA
C7HVX	CR7HIX
C8HV	C8HVX
C9EH-9	CR9EH-9
C9EHVX-9	CR9EHIX-9
CR6HS	CR6HSA
CR8EKPA	-
CR8HS	CR8HSA
CR9EHVX-9	CR9EHIX-9
D10HS	-
D7EV	D7EVX
D8EV	DR8EIX
D8EVX	DR8EIX
D9EV	DR9EIX
D9EVX	DR9EIX
DCP7EVX	DCPR7EIX
DCPR7EVX	DCPR7EIX

Discontinued No.	Replacement No.
DP6EA-9	DPR6EA-9
DP9EV-9	DP9EVX-9
DPR7EVX-9	DPR7EIX-9
DPR8EV-9	DPR8EIX-9
DPR9EV-9	DPR9EIX-9
DPR9EVX-9	DPR9EIX-9
DR9EVX	DR9EIX
ER8EH	-
F23	-
IFR6F-7D	BKR6EIX-P
IFR7G-11K	IFR7G-11KS
IGR7E-3D	-
J10A	-
J9B	JR9B
JR10B	-
L8A	C8HSA
LZTR5AIX-13	LZTR5A-13
PFR6A-11N	PFR6G-11
PFR7G-11	PFR7G-11S
PZFR5N-11TG	PZFR5N-11T
R015-10	-
R016-10	R0373A-10
R017-10	R0373A-10
R017-11	-
R017-9	R0373A-9
R0256B-11	-
R0045G-11	-
R0045Q-11	-
R2098-10N	-
R2098-11N	-
R216-10	R2525-10
R216-12	-
R217-10	R2525-10
R217-12	-
R217-9	-
R217-95	-
R2349-9	-
R2525-11	-
R4118M-8	R4118S-8
R4118M-9	R4118S-9
R4339-10	BR10EG
R4339-8	B8EG
R4339-9	B9EG
R4468-11	R6725-11
R4468-115	R6725-115
R4468A-11	R6725-11
R4468A-115	R6725-115
R4630A-105	-
R5300A-105	R7282-105

Discontinued No.	Replacement No.
R5300A-11	-
R5400-10	R7435-10
R5400-7	IRITOP7
R5400-9	R7435-9
R5530-9	-
R5540-10	-
R5540-105	R5540F-105
R5540B-105	R5540F-105
R5540F-10	-
R5686-10	R7435-10
R5686-8	R7435-8
R5686-9	R7435-9
R5830-9	(R7238-10)
R5883-10	-
R6120-105	R7282-105
R6254E-9	-
R6254K-105	-
R6337-8	R7435-8
R6337-9	R7435-9
R6385-105P	-
R6385-10P	R7376-10
R6385-8P	-
R6725-105	-
R7112-7	IRIWAY7
R7112-10	-
R7113-9	-
R7119-9	-
R7232-10	R7435-10
R7232-7	IRITOP7
R7232-8	R7435-8
R7232-9	R7435-9
R7234-10	R7435-10
R7234-8	R7435-8
R7234-9	R7435-9
R7282M-105	-
RE7A-L	RE7C-L
SD10	BUR7EQ/BUR9EQ
SD8	BUR7EQ/BUR9EQ
SD9	BUR7EQ/BUR9EQ
SR5	TR5-1
TR4-2	TR4
TR4VX	TR4IX
TR5A-13	-
TR5-1VX	TR5-1IX
TR55VX	TR55IX
TR5VX	TR5IX
U0019	-
UR55VX	UR55IX
UR5VX	UR5IX



DISCONTINUED & REPLACEMENT LIST SPARK PLUGS & SPARK PLUG RESISTOR CAPS

SPARK PLUGS

Discontinued No.	Replacement No.
UR6VX	UR6IX
XFR5A-11	PFR5G-11
XFR5B-11	–
XFR6A-11	PFR6G-11
XFR6B-11	–
XR4VX	XR4IX
XR5VX	XR5IX
ZF5A-11	ZFR5F-11
ZF7A-11	ZFR7F-11
ZFR4D-11	–
ZFR6FVX-11	ZFR6FIX-11
ZG5A	ZGR5A
ZGR5E	BPR5EY
ZGR6A	BPR6EY
ZTR7A	BR7EF

SPARK PLUG RESISTOR CAPS

Discontinued No.	Replacement No.
TB05EM	TB05EM-B
LBER	LBER-R
TRS1408F	TRS1408F-B
TRS1225	TRS1225-B



GLOSSARY

GLOSSARY OF ABBREVIATIONS (ACRONYMS)

Engine Configuration	
Acronym	Meaning
2 Cyl	2 Cylinders
3 Cyl	3 Cylinders
4 Cyl	4 Cylinders
5 Cyl	5 Cylinders
F4 Cyl	Flat 4 Cylinders
F6 Cyl	Flat 6 Cylinders
I5 Cyl	Inline 5 Cylinders
I6 Cyl	Inline 6 Cylinders
I8 Cyl	Inline 8 Cylinders
R2 Cyl	Rotary 2 Cylinders
RT2 Cyl	Rotary Turbo 2 Cylinders
V4 Cyl	V4 Cylinders
V5 Cyl	V5 Cylinders
V6 Cyl	V6 Cylinders
V8 Cyl	V8 Cylinders
V10 Cyl	V10 Cylinders
V12 Cyl	V12 Cylinders
Cylinder Head Design	
Acronym	Meaning
DOHC	Double Over Head Cam
DOHV	Double Over Head Valves
OHC	Over Head Cam
OHV	Over Head Valve
SOHC	Single Over Head Cam
V-DOHC	Variable Timing Double Over Head Cam
V-OHV	Variable Timing Over Head Valve
V-SOHC	Variable Timing Single Over Head Cam
Induction Design	
Acronym	Meaning
4Cam	4 Cam Shafts
Carb	Carburettor
2Carb	2 Carburettors
3Carb	3 Carburettors
4Carb	4 Carburettors
6Carb	6 Carburettors
DFI	Diesel Fuel Injection
DI	Direct Injection
DMPFI	Diesel Multi Point Fuel Injection
DT	Diesel Turbo
DTFI	Diesel Turbo Fuel Injection
EFI	Electronic Fuel Injection
FI	Fuel Injection
GDI	Gasoline Direct Injection
MPFI	Multi Point Fuel Injection
SCEFI	Supercharged Electronic Fuel Injection

GLOSSARY OF ABBREVIATIONS (ACRONYMS)

Induction Design (cont)	
SCMPFI	Supercharged Multi Point Fuel Injection
SPFI	Single Point Fuel Injection
TBI	Throttle Body Injection
TCarb	Turbo Carburettor
TCDI	Turbo Common Rail Direct Injection
TDI	Turbo Direct Injection
TEFI	Turbo Electronic Fuel Injection
TFI	Turbo Fuel Injection
TMPFI	Turbo Multi Point Fuel Injection
TSPFI	Turbo Single Point Fuel Injection
TTBI	Turbo Throttle Body Injection
TTEFI	Twin Turbo Electronic Fuel Injection
TTMPFI	Twin Turbo Multi Point Fuel Injection
Miscellaneous	
Acronym	Meaning
Cyl	Cylinder
Dist	Distributor
Eng	Engine
HEI	High Energy Ignition
HEI Boot	Female-Terminal Boot Design
kW	Kilowatt
Standard Boot	Male-Terminal Boot Design
S/P	Spark Plug
Trans	Transmission
VIN	Vehicle Identification Number



SAM ALLEN WHOLESale
Marine, RV & Industrial Accessories

Proudly Distributed by: *Sam Allen Wholesale*
385 Thynne Road,
Morningside, Queensland 4170
P: +61 7 3902 7222
F: +61 7 3899 1079
E: sales@samallen.com.au
W: www.samallen.com.au

